

NFPA Pneumatic Cylinders

4MA / 4ML Series - Non-Lube NFPA Air Cylinders

1-1/2" to 5" Bore Sizes

Features / Ordering Information	B2-B3
Mounting Styles	B4
Body Orientations	B5
Specifications	B6-B8
Dimensional Data	B9-B16
Accessories / Service Kits	B34-B35

6" to 8" Bore Sizes

Features / Ordering Information	B18-B19
Mounting Styles	B20
Specifications	B21-B23
Dimensional Data	B24-B33
Accessories / Service Kits	B34-B35

4MAJ Series (Rod Lock Option)

Features / Ordering Information	B37-B40
Mounting Styles	B41
Specifications	B42-B43
Dimensional Data	B44-B61

ACVB Option - Valve Mounted to Cylinder	B62-B71
---	---------

LPSO Option - Linear Position Sensor	B72-B76
--------------------------------------	---------

Standard Options	B77-B79
------------------	---------

Accessories	B80-B81
-------------	---------

Maintenance and Service Kits	B82-B91
------------------------------	---------

Non-Rotating Pneumatic Cylinders

2MNR Non-Rotating

Features / Ordering Information	B92-B93
Mounting Styles	B94
Specifications / Technical Data	B95-B96
Dimensional Data	B97-B102
Accessories / Service Kits	B103

ISO Pneumatic Cylinders

P1D ISO Pneumatic Cylinders

Options	B104-B105
Features / Ordering Information	B106-B107
Specifications	B108-B109
Technical Data	B110-B112
Dimensional Data	B113-B117
Rod End Dimensions (Mounting and Rod End Kits)	B118
Tandem and Duplex Cylinders	B119
Accessories / Service Kits	B120-B129

B
**Tie Rod Pneumatic
Cylinders**

Features

4MA/4ML Series – 1-1/2" to 5" Bore Size

B	Tie Rod Pneumatic Cylinders
	Series
4MA	Series
4MAJ	Series
2MNR	Series
ACVB	Option
LPSO	Option
P1D	Series

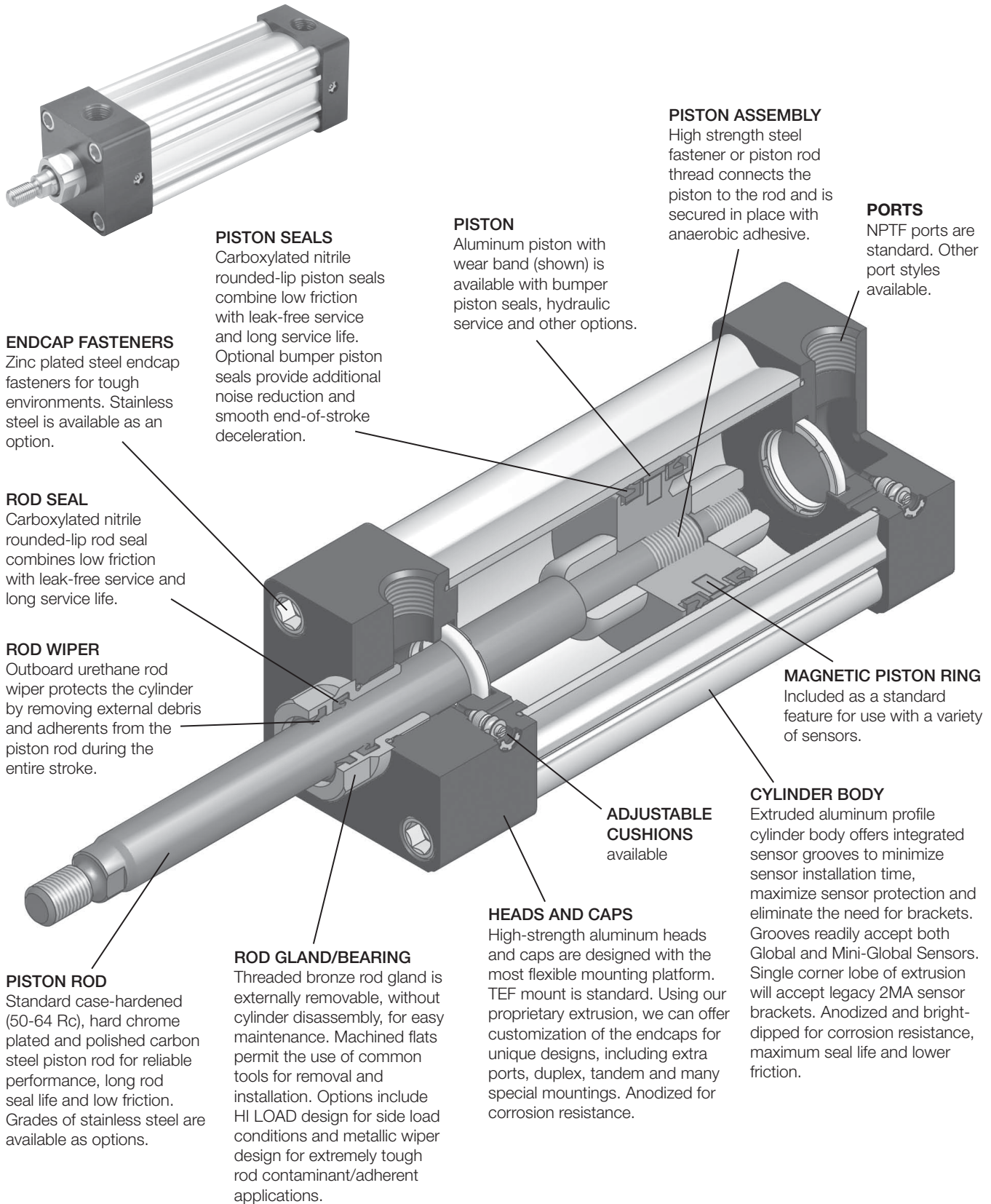

For a complete list of 4MA options, please see pages B3 and B8.



For inventory, lead times, and kit lookup, visit www.pdnplu.com

Tie Rod Pneumatic Cylinders

4MA/4ML Series – 1-1/2" to 5" Bore Size

Features

- Industry leading aluminum NFPA interchangeable cylinder with flexible construction
- Bore sizes – 1-1/2", 2", 2-1/2", 3-1/4", 4" and 5"
- Removable bronze alloy gland/bearing for easy maintenance
- Available in any practical stroke length
- 20 standard mounting styles available
- Extruded-profile aluminum body with integrated switch grooves
- Single rod end or double rod ends
- Cushions – standard and adjustable at both ends, optional non-cushioned
- RoHS compliant



Operating information

	4MA	4ML
Operating pressure:	250 PSIG (17 bar) maximum air service	400 PSIG (27 bar) maximum hydraulic service
Temperature range –		
Standard seals	-10°F to 165°F (-23°C to 74°C)	
Fluorocarbon seals	-10°F to 250°F (-23°C to 121°C)	
Low temperature seals	-50°F to 150°F (-46°C to 66°C)	
Filtration requirements:	40 micron, dry filtered air	Filtered hydraulic oil

Ordering information

2.00	J	4MA	U	1	4	A	6.000
Bore size 1.50 ¹ 2.00 2.50 3.25 4.00 5.00	Double rod cylinder ¹² Specify "K" only if double rod cylinder is required.	Series 4MA Air service 4ML Hydraulic service ²	Ports U NPTF R BSPP B BSPT T SAE	Piston rod number Specify rod code number for required diameter. ^{8, 2}	Special modification Specify "S" only for special modification other than rod end, and then describe modification in item notes. (Includes 4MA with Linear Position Sensor Option) ⁷	Cushion cap end Blank Non-cushioned cap end C Cushioned cap end (not available for 4ML)	Stroke length Specify stroke length required in inches. ¹¹
Mounting style Specify mounting style code (see table on following page).	Cushion head end Blank Non-cushioned head end C Cushioned head end (not available for 1.50" bore with 1" rod or 4ML)	Cylinder construction Blank* Standard (extruded body, standard round lobe orientation) A* Extruded body, round lobe orientation rotated 90 degrees from standard N* Extruded body, round lobe orientation rotated 180 degrees from standard Z* Extruded body, round lobe orientation rotated 270 degrees from standard T Aluminum round tube and carbon steel tie rods & nuts	Seals Blank Standard (nitrile seals) V Fluorocarbon seals ⁴ E Fluorocarbon rod wiper and rod seal only ⁵ 4 Low temperature seals ⁴ M Metallic rod wiper, nitrile seals ⁶	Piston rod thread type A Standard (UNF unified thread) W BSF British fine M* Metric	Seals Blank Standard (nitrile seals) V Fluorocarbon seals ⁴ E Fluorocarbon rod wiper and rod seal only ⁵ 4 Low temperature seals ⁴ M Metallic rod wiper, nitrile seals ⁶	Piston rod thread style 4 Small male 8 Intermediate male 9 Short female 55 For use with split coupler ⁹ 3 Special (and specify all dimensions required) 6 Full male	Rod material and gland code Blank Standard rod and gland H Standard rod and HI LOAD gland Y 17-4 PH stainless steel rod and standard gland Z 17-4 PH stainless steel rod and HI LOAD gland J 303 stainless steel rod and standard gland ¹⁰ K 303 stainless steel rod and HI LOAD gland ¹⁰ S 316 stainless steel rod and standard gland ¹⁰ T 316 stainless steel rod and HI LOAD gland ¹⁰
Piston type ² Blank Lipseals and magnetic ring (legacy) (standard for 4ML) 1 Lipseals, no magnetic ring (legacy) 2 Lipseals, no magnetic ring (aluminum piston) 3 Lipseals and magnetic ring (aluminum piston) (standard for 4ML) 4 Bumper seals, no magnetic ring 6 Bumper seals and magnetic ring B Lipseals, 1/4" thick bumpers both ends ³ H Lipseals, 1/4" thick bumper head end ³ C Lipseals, 1/4" thick bumper cap end ³ D Lipseals and magnetic ring, 1/4" thick bumpers both ends ³ F Lipseals and magnetic ring, 1/4" thick bumper head end ³ R Lipseals and magnetic ring, 1/4" thick bumper cap end ³	Special modification Specify "S" only for special modification other than rod end, and then describe modification in item notes. (Includes 4MA with Linear Position Sensor Option) ⁷	Seals Blank Standard (nitrile seals) V Fluorocarbon seals ⁴ E Fluorocarbon rod wiper and rod seal only ⁵ 4 Low temperature seals ⁴ M Metallic rod wiper, nitrile seals ⁶	Piston rod thread style 4 Small male 8 Intermediate male 9 Short female 55 For use with split coupler ⁹ 3 Special (and specify all dimensions required) 6 Full male	Piston rod thread type A Standard (UNF unified thread) W BSF British fine M* Metric	Seals Blank Standard (nitrile seals) V Fluorocarbon seals ⁴ E Fluorocarbon rod wiper and rod seal only ⁵ 4 Low temperature seals ⁴ M Metallic rod wiper, nitrile seals ⁶	Piston rod thread style 4 Small male 8 Intermediate male 9 Short female 55 For use with split coupler ⁹ 3 Special (and specify all dimensions required) 6 Full male	Rod material and gland code Blank Standard rod and gland H Standard rod and HI LOAD gland Y 17-4 PH stainless steel rod and standard gland Z 17-4 PH stainless steel rod and HI LOAD gland J 303 stainless steel rod and standard gland ¹⁰ K 303 stainless steel rod and HI LOAD gland ¹⁰ S 316 stainless steel rod and standard gland ¹⁰ T 316 stainless steel rod and HI LOAD gland ¹⁰

* See table on page B5. Only applies to 1-1/2" to 4" bore size.

¹ Not available with Linear Position Sensor Option (LPSO).
² Piston Types (blank), 1, 4 and 6 not available for 4ML. Piston Types (blank) and 1 not available for oversize rod numbers 2 and 3. Seals option V only available with Piston Types 2 and 4. Seals option 4 only available with Piston Types 2 and 3.
³ Addition of 1/4" bumper results in a 1/4" stroke loss per bumper, per end. For example, a 6" stroke cylinder with 1/4" bumpers at both ends (option B) has an effective stroke of 5-1/2".
⁴ Reed and solid-state sensors only available with standard seals or options E and M. See footnote 2.
⁵ Used for external chemical compatibility applications, not high temperature.
⁶ If fluorocarbon seals are required with this option, please place an "S" for special in the Special Modification field and specify the "fluorocarbon seals and metallic rod wiper" in the item notes.
⁷ For Linear Position Sensor Option (LPSO), please include the following information for the Special Modification item notes:
 a. Sensor part number reference LPSO section
 b. Sensor position
 c. Port position (if other than position 1)
 d. Length of stop tubing, gross stroke and net stroke (if required)
 Also, Piston Type option (blank), 3, 6, D, F or R is required.
⁸ Review Piston Rod Selection Chart, please reference page A14 to determine proper piston rod diameter.
⁹ For additional information regarding this style, please reference page B77. If non-standard Rod Material and Gland Code is required with this option, please place an "S" for special in the Special Modification field and specify Rod Material and Gland Code in the item notes.
¹⁰ Not available for 4MA.
¹¹ If a stop tube is required, specify gross stroke (net stroke + stop tube) in the model number, then place an "S" for special in the Special Modification field and specify the stop tube length in the item notes.

For ordering purposes, when special options or common modifications are requested, the factory will assign a sequential part number in place of the model number.



For inventory, lead time, and kit lookup, visit www.pdnplu.com

Mounting Styles

Tie Rod Pneumatic Cylinders 4MA/4ML Series – 1-1/2" to 5" Bore Size

4MA/4ML Mounting Styles for 1-1/2" to 5" Bore

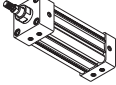
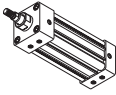
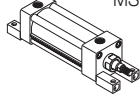
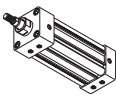
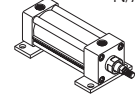
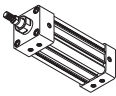
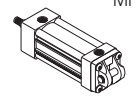
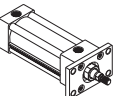
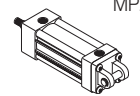
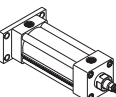
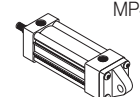
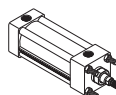
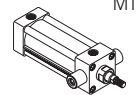
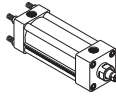
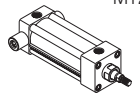
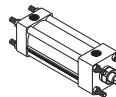
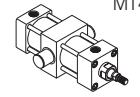
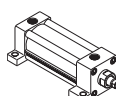
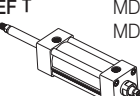
Mounting style	NFPA mounting	Description	Bore size	Mounting style	NFPA mounting	Description	Bore size	
 TEF	MX5/MS4	Sleeve Nut with Side Tap (standard mount)	4MA/4ML w/LPSO w/LPSO w/stop tube	1-1/2 - 5*	2 - 5 2 - 5	 CB	MS1 Side End Angle 4MA/4ML w/LPSO w/LPSO w/stop tube	1-1/2 - 5 2 - 5 2 - 5
 T	MX0	No Mount (same construction as TEF)	4MA/4ML w/LPSO w/LPSO w/stop tube	1-1/2 - 5 2 - 5 2 - 5	 G	MS7 Side End Lug 4MA/4ML w/LPSO w/LPSO w/stop tube	1-1/2 - 4* 2 - 4 2 - 4	
 TE	MX5	Sleeve Nut (same construction as TEF)	4MA/4ML w/LPSO w/LPSO w/stop tube	1-1/2 - 5 2 - 5 2 - 5	 NB	N/A Base Bar 4MA/4ML w/LPSO w/LPSO w/stop tube	1-1/2 - 4* 2 - 4 2 - 4	
 F	MS4	Side Tap (same construction as TEF)	4MA/4ML w/LPSO w/LPSO w/stop tube	1-1/2 - 5* 2 - 5 2 - 5	 BB	MP1 Cap Fixed Clevis 4MA/4ML w/LPSO w/LPSO w/stop tube	1-1/2 - 5 2 - 5** 2 - 5**	
 J	MF1	Head Rectangular Flange	4MA/4ML w/LPSO w/LPSO w/stop tube	1-1/2 - 5 2 - 5** 2 - 5	 BC	MP2 Cap Detachable Clevis 4MA/4ML w/LPSO w/LPSO w/stop tube	1-1/2 - 5 2 - 5** 2 - 5**	
 H	MF2	Cap Rectangular Flange	4MA/4ML w/LPSO w/LPSO w/stop tube	1-1/2 - 5 2 - 5** 2 - 5**	 BE	MP4 Cap Detachable Eye 4MA/4ML w/LPSO w/LPSO w/stop tube	1-1/2 - 5 2 - 5** 2 - 5**	
 TB	MX3	Tie Rods Extended Head End	4MA/4ML w/LPSO w/stop tube	1-1/2 - 5 2 - 5	 D	MT1 Head Trunnion 4MA/4ML w/LPSO w/LPSO w/stop tube	1-1/2 - 5* 2 - 5 2 - 5	
 TC	MX2	Tie Rods Extended Cap End	4MA/4ML	1-1/2 - 5	 DB	MT2 Cap Trunnion 4MA/4ML w/LPSO w/LPSO w/stop tube	1-1/2 - 5 2 - 5** 2 - 5**	
 TD	MX1	Tie Rods Extended Both Ends	4MA/4ML	1-1/2 - 5	 DD	MT4 Intermediate Trunnion 4MA/4ML	1-1/2 - 5	
 C	MS2	Side Lug	4MA/4ML w/LPSO w/LPSO w/stop tube	1-1/2 - 5 2 - 5 2 - 5	 KTEF †	MDX5/ MDS4 Double Rod End, TEF Mount 4MA/4ML w/LPSO w/LPSO w/stop tube	1-1/2 - 5 2 - 5 2 - 5	

* Not available for 1-1/2" bore with 1" rod.

** May interfere with mounting. Please provide clearance for Linear Sensor overhang (see page B73).

† Double rod end cylinders can be ordered with head mountings, i.e. KJ.

Sensors

See section L for sensors.



Kits & Accessories

See page B34.



For inventory, lead times, and kit lookup, visit www.pdnplu.com

Body Orientations

4MA Extruded Cylinder Body Sensor Slot Orientation

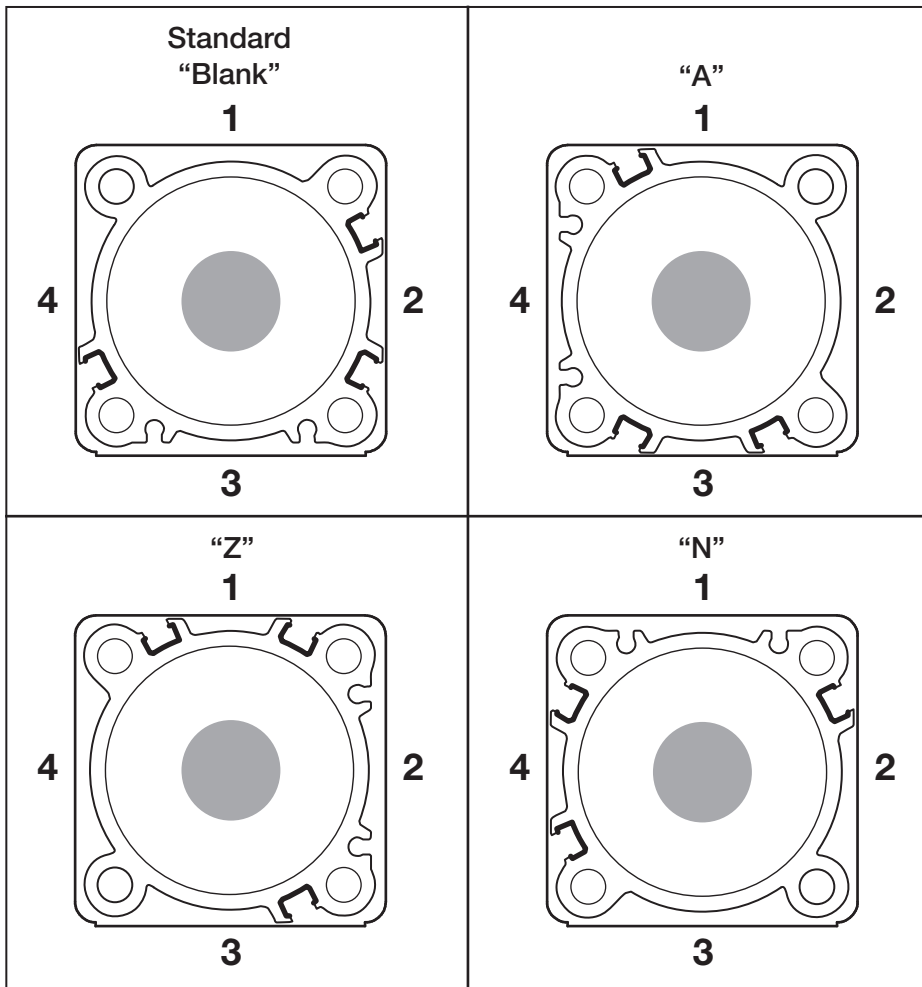

* Only applies to 1-1/2" to 4" Bore

B
Tie Rod Pneumatic Cylinders
4MA Series
4MAJ Series
2MNR Series
ACVB Option
LPSO Option
P1D Series



For inventory, lead time, and kit lookup, visit www.pdnplu.com

Specifications

Tie Rod Pneumatic Cylinders 4MA/4ML Series – 1-1/2" to 5" Bore Size

General Specifications

- NFPA interchangeable
 - Bore sizes – 1-1/2", 2", 2-1/2", 3-1/4", 4" and 5"
 - Strokes – available in any practical stroke length
 - Rod diameters – 5/8", 1" and 1-3/8"
 - Rod end styles – 4 standard, specials available
 - Single rod end or double rod ends
 - Cushions – optional and adjustable at either end or both ends (N/A for 4ML Hydraulic Version)
 - Operating pressure –
4MA = 250 PSIG (17 bar) maximum air service
4ML = 400 PSIG (27 bar) maximum hydraulic service
 - Media – 4MA = dry, filtered air
4ML = filtered hydraulic oil
 - Temperature range –
-10°F to 165°F (-23°C to 74°C) standard seals
-10°F to 250°F (-23°C to 121°C) fluorocarbon seals option
-50°F to 150°F (-46°C to 66°C) low temperature seals option
 - Mounting styles – 20 standard styles
 - RoHS compliant
- For material options, including seals, piston rods and glands, please see Material Specifications on next page.

Cylinder Weights – 4MA / 4ML Cylinders

Bore (inch)	Rod (inch)	No mount single rod 4MA/4ML		No mount double rod	
		Base wt. (lbs.)	Per inch (lbs.)	Base wt. (lbs.)	Per inch (lbs.)
1-1/2	0.625	1.73	0.20	2.16	0.28
	1.00	2.99	0.35	4.34	0.58
2	0.625	2.40	0.21	3.05	0.30
	1.00	2.99	0.35	4.34	0.58
2-1/2	0.625	3.25	0.23	3.96	0.31
	1.00	4.06	0.37	5.74	0.60
3-1/4	1.00	6.45	0.42	7.65	0.64
	1.375	7.93	0.62	11.46	1.05
4	1.00	8.80	0.49	10.32	0.71
	1.375	10.29	0.69	14.37	1.12
5	1.00	13.20	0.61	15.84	0.84
	1.375	14.72	0.81	18.89	1.24

Standard Cushion Position

Mounting Code	Position
All except D, DB, DD	2
D, DB, DD	3

Standard Port Sizes

Bore	NPTF	BSPT	BSPP	SAE
1-1/2	3/8	Rc3/8	G3/8	6
2	3/8	Rc3/8	G3/8	6
2-1/2	3/8	Rc3/8	G3/8	6
3-1/4	1/2	Rc1/2	G1/2	10
4	1/2	Rc1/2	G1/2	10
5	1/2	Rc1/2	G1/2	10

Mounting Weight Adders

Bore (inch)	Mounting style, weight (lbs)							
	J, H	D, DB	BB	CB, G	DD	BE	C	BC
1-1/2	0.51	0.50	0.15	0.36	1.70	0.23	0.15	0.20
2	0.76	0.50	0.26	0.65	2.38	0.32	0.15	0.29
2-1/2	1.13	0.50	0.38	1.05	3.00	0.42	0.15	0.41
3-1/4	2.76	0.50	0.98	1.38	5.35	1.26	0.35	1.06
4	4.05	0.50	1.35	2.20	6.75	1.62	0.35	1.49
5	6.46	0.50	1.20	4.29	8.77	1.26	0.57	2.41

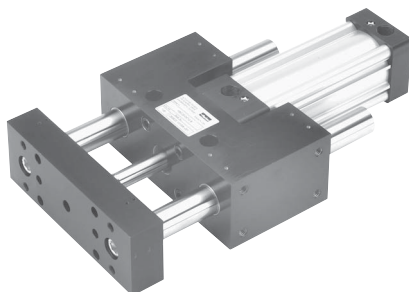

For a guided version of the 4MA or 4ML Series, please see the HB Series in Section E.

Material Specifications

Standard Temperatures and Applications

Head and cap	Black anodized aluminum alloy
Head and cap screws	Zinc plated steel alloy
Cylinder body	Clear anodized aluminum alloy
Piston rod	Case-hardened, chrome plated carbon steel
Rod seal	Carboxylated nitrile (Nitroxile)
Rod wiper	Molythane
Rod bearing (gland)	Bronze alloy
Piston	Aluminum alloy
Piston seals	Carboxylated nitrile (Nitroxile)
Piston bearing	Composite (for standard piston) MolyGard™ (for aluminum piston)
Magnetic ring	Plastic-bound magnetic material
Piston fastener	Piston rod for aluminum piston
O-rings	Nitrile
End seals	Nitrile
Cushion seals	Urethane
Cushion needle valves	Stainless steel
Tie-rods/studs	Blackened carbon steel 1018 (some mounts)
Tie-rod nuts	Steel alloy, SAE J995 Grade 8 (some mounts)

Tie Rod Pneumatic Cylinders 4MA/4ML Series – 1-1/2" to 5" Bore Size

Material and Part Changes

4MA Options

High temperatures (-10°F to 250°F)	All seals and wiper are fluorocarbon Aluminum piston without magnetic ring
Low temperatures (-50°F to 150°F)	Rod seal, piston seals, o-rings and end seals are low temperature-rated nitrile

4ML Hydraulic Version

Hydraulic service (general)	Cushions and bumper piston seals not available
Hydraulic service (std temp)	Polyurethane TS-2000 rod seal and nitrile piston seals (for hydraulic use)
Hydraulic service (high temp)	Fluorocarbon TS-2000 rod seal; wiper and all seals are fluorocarbon (for hydraulic use)

Other Standard Options

Cylinder seal options	Fluorocarbon for high temperatures or chemical compatibility Other seal options available, please consult factory
Bumper piston seal options (4MA only, N/A for 4ML)	Carboxylated nitrile (Nitroxile) for standard temperatures Fluorocarbon for high temperatures or chemical compatibility
1/4" thick bumpers option	Urethane
Piston rod material options	Case-hardened, chrome plated carbon steel (standard) 17-4 PH stainless steel, chrome plated 303 stainless steel, chrome plated (N/A for 4ML) 316 stainless steel, chrome plated (N/A for 4ML) For stainless steel without chrome plating, please consult factory
HI LOAD gland option	Composite bearing pressed into bronze alloy gland
Metallic rod scraper option	Dual high strength bronze wipers with PTFE (5/8" rod only) or fluorocarbon energizer

B

Tie Rod Pneumatic Cylinders

4MA Series

4MAJ Series

2MNR Series

ACVB Option

LPSO Option

P1D Series



For inventory, lead time, and kit lookup, visit www.pdnplu.com

How to Select a 1-1/2" to 5" Bore 4MA Cylinder

Parker cylinders are available based on air or hydraulic operating pressure. The many styles, sizes and optional features available assure that your application requirements are precisely met. To select a cylinder, follow these simple steps:

- Step 1 - **Determine the correct cylinder bore size** necessary to achieve required force using the available operating pressure.
- Step 2 - **Determine the series cylinder to use**, based on operating pressure.
- Step 3 - **Turn to the appropriate cylinder selection section.** Select the mounting style that fits your installation needs. Determine the bore and rod sizes available for the model you select. Then complete model selection.
 - Choose a rod end style and the desired rod end accessories.
 - Size the cylinder to meet your application requirements.
- Step 4 - **Consider the following conditions** which may require further modifications to the cylinder you have selected.

Application Condition	Check the Following
Quick Starts or Stops	Confirm that determined thrust is sufficient to accelerate or decelerate cylinder and load within prescribed distance. Optional cushions should be used to reduce shock during deceleration, check that peak pressures will be within tolerable limits.
Long Push Stroke	Check whether stop tube is required to prevent excessive bearing loads and wear.
High-column Loading Long Push Stroke	Determine if standard size piston rod is strong enough to accommodate intended load. See Application Engineering section for recommendations.
Long Horizontal Stroke	Determine if standard size piston rod is strong enough to accommodate intended load.
High Operating Temperatures	For temperatures between 165°F and 250°F use 4MA or 4ML cylinder with high temperature seals.

General Options and Modifications:

- Adjustable Cushions
- Non-Magnetic Piston (magnetic ring standard)
- Piston Bumper Seals
- Piston Bumpers (1/4" thick)
- Port and Adjustable Cushion Relocation
- Port Thread Styles
- Multiple Ports
- Special Heads, Caps, Pistons and Mounts
- Double Rod End
- Oversize Rod Diameters
- Rod End Modifications
- Rod Materials (grades of stainless steel)
- Fluorocarbon Rod Wiper and Rod Seal only
- Fluorocarbon Seals (all cylinder seals)
- Metallic Rod Wiper
- HI LOAD Gland Assembly
- Stop Tube
- Mixed Mountings
- Round Tube and Tie Rod Construction
- Stainless Steel Fasteners/Tie Rods
- Shock Absorber on Cap End
- NuCushion Bumpers
- Hydro-Check unit for smooth hydraulic control
- Air Cylinder/Valve Combination (ACVB)
- Adjustable Point Sensors (order separately)
- Continuous Linear Position Sensing (LPSO)
- High Temperature Service (to 250°F)
- Low Temperature Service (to -50°F)
- Hydraulic Service (4ML) (400 PSIG)
- Rod lock version (see 4MAJ)

B
Tie Rod Pneumatic
Cylinders

4MA
Series

4MAJ
Series

2MNR
Series

ACVB
Option

LPSO
Option

P1D
Series



For inventory, lead times, and kit lookup, visit www.pdnplu.com

Single Rod
(Styles TEF, T, TE and F)

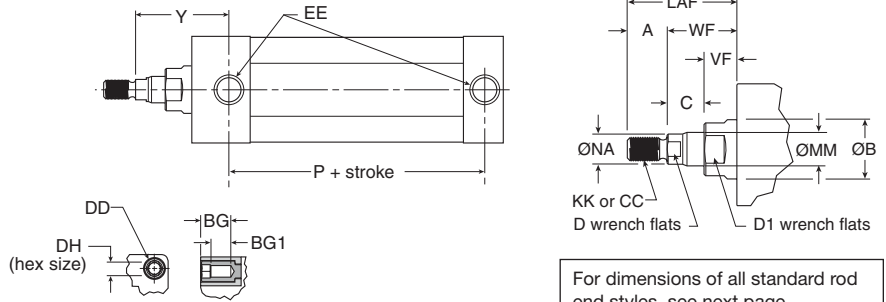
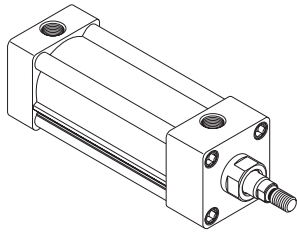

For dimensions of all standard rod end styles, see next page.

1-1/2" bore with 1" rod is TE mount, F mount not available.
 1-1/2" bore with 1" rod cannot have a cushion at head end.

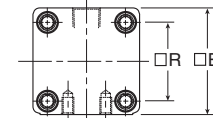
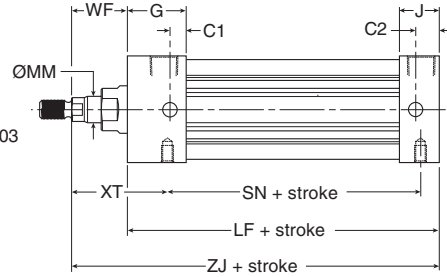
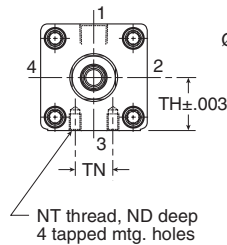

Styles TEF, T, TE and F

Bore size	Rod no.	Rod dia.		Thread			Style 4													EE (NPTF)
		MM	CC	Style 8	Style 9 & 9	Style 6	A	AA	B	BG	BG1	C	C1	C2	D	D1	DD	DH	E	
1-1/2	1	5/8	1/2 - 20	7/16 - 20	5/8 - 18	0.750	2.020	1.124	0.562	0.374	0.385	1.000	0.500	1/2	1	1/4 - 28	1/4	2.000	3/8	
	2*	1	7/8 - 14	3/4 - 16	1 - 14	1.125	2.020	1.499	0.562	0.374	0.510	-	0.500	7/8	1-3/8	1/4 - 28	1/4	2.000	3/8	
2	1	5/8	1/2 - 20	7/16 - 20	5/8 - 18	0.750	2.600	1.124	0.562	0.362	0.385	1.000	0.562	1/2	1	5/16 - 24	5/16	2.500	3/8	
	3	1	7/8 - 14	3/4 - 16	1 - 14	1.125	2.600	1.499	0.562	0.362	0.510	1.000	0.562	7/8	1-3/8	5/16 - 24	5/16	2.500	3/8	
2-1/2	1	5/8	1/2 - 20	7/16 - 20	5/8 - 18	0.750	3.100	1.124	0.562	0.362	0.385	1.000	0.594	1/2	1	5/16 - 24	5/16	3.000	3/8	
	3	1	7/8 - 14	3/4 - 16	1 - 14	1.125	3.100	1.499	0.562	0.362	0.510	1.000	0.594	7/8	1-3/8	5/16 - 24	5/16	3.000	3/8	
3-1/4	1	1	7/8 - 14	3/4 - 16	1 - 14	1.125	3.900	1.499	0.700	0.500	0.510	1.188	0.719	7/8	1-3/8	3/8 - 24	3/8	3.750	1/2	
	3	1-3/8	1-1/4 - 12	1 - 14	1-3/8 - 14	1.625	3.900	1.999	0.700	0.500	0.635	1.188	0.719	1-1/8	1-7/8	3/8 - 24	3/8	3.750	1/2	
4	1	1	7/8 - 14	3/4 - 16	1 - 14	1.125	4.700	1.499	0.700	0.500	0.510	1.188	0.719	7/8	1-3/8	3/8 - 24	3/8	4.500	1/2	
	3	1 3/8	1-1/4 - 12	1 - 14	1-3/8 - 14	1.625	4.700	1.999	0.700	0.500	0.635	1.188	0.719	1-1/8	1-7/8	3/8 - 24	3/8	4.500	1/2	
5	1	1	7/8 - 14	3/4 - 16	1 - 14	1.125	5.800	1.499	0.781	0.531	0.510	1.188	0.813	7/8	1-3/8	1/2 - 20	1/2	5.500	1/2	
	3	1 3/8	1-1/4 - 12	1 - 14	1-3/8 - 14	1.625	5.800	1.999	0.781	0.531	0.635	1.188	0.813	1-1/8	1-7/8	1/2 - 20	1/2	5.500	1/2	

Bore size	Rod no.	Rod dia.		Style 4													Add stroke			
		MM	G	J	LAF	NA	ND	NT	R	TH	TN	VF	WF	XT	Y	LF	P	SN	ZJ	
1-1/2	1	5/8	1.438	0.938	1.750	0.563	0.375	1/4 - 20	1.430	0.993	0.625	0.615	1.000	1.938	1.875	3.625	2.313	2.250	4.625	
	2*	1	1.438	0.938	2.500	0.938	-	-	1.430	0.993	-	0.865	1.375	-	2.250	3.625	2.313	-	5.000	
2	1	5/8	1.375	0.937	1.750	0.563	0.438	5/16 - 18	1.840	1.243	0.875	0.615	1.000	1.938	1.875	3.625	2.313	2.250	4.625	
	3	1	1.375	0.937	2.500	0.938	0.375	5/16 - 18	1.840	1.243	0.875	0.865	1.375	2.313	2.250	3.625	2.313	2.250	5.000	
2-1/2	1	5/8	1.344	0.938	1.750	0.563	0.625	3/8 - 16	2.190	1.493	1.250	0.615	1.000	1.938	1.938	3.750	2.375	2.375	4.750	
	3	1	1.344	0.938	2.500	0.938	0.625	3/8 - 16	2.190	1.493	1.250	0.865	1.375	2.313	2.313	3.750	2.375	2.375	5.125	
3-1/4	1	1	1.594	1.125	2.500	0.938	0.750	1/2 - 13	2.760	1.868	1.500	0.865	1.375	2.438	2.438	4.250	2.625	2.625	5.625	
	3	1-3/8	1.594	1.125	3.250	1.313	0.750	1/2 - 13	2.760	1.868	1.500	0.990	1.625	2.688	2.688	4.250	2.625	2.625	5.875	
4	1	1	1.594	1.125	2.500	0.938	0.750	1/2 - 13	3.320	2.243	2.063	0.865	1.375	2.438	2.438	4.250	2.625	2.625	5.625	
	3	1-3/8	1.594	1.125	3.250	1.313	0.750	1/2 - 13	3.320	2.243	2.063	0.990	1.625	2.688	2.688	4.250	2.625	2.625	5.875	
5	1	1	1.594	1.219	2.500	0.938	0.938	5/8 - 11	4.100	2.743	2.688	0.865	1.375	2.438	2.438	4.500	2.875	2.875	5.875	
	3	1 3/8	1.594	1.219	3.250	1.313	0.938	5/8 - 11	4.100	2.743	2.688	0.990	1.625	2.688	2.688	4.500	2.875	2.875	6.125	

* NOTE - 1-1/2" bore with 1" rod is TE mount, F mount not available.
 1-1/2" bore with 1" rod cannot have a cushion at head end.



For inventory, lead time, and kit lookup, visit www.pdnplu.com

Rod End Thread Styles

Tie Rod Pneumatic Cylinders 4MA Series – 1-1/2" to 5" Bore Size

Thread Style Rod End

Thread Style 4
(NFPA Style SM)
Small Male

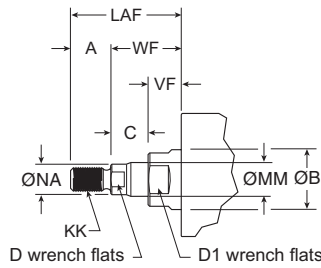

Thread Style 8
(NFPA Style IM)
Intermediate Male

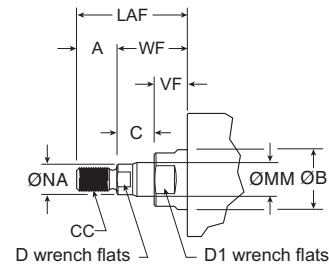

Thread Style 9
(NFPA Style SF)
Short Female

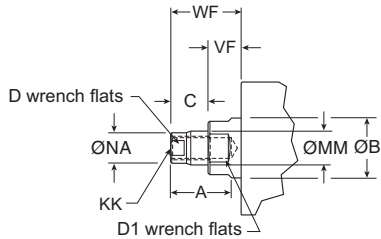

Thread Style 55
For use with Split Coupler
(please reference page B77 for more information)

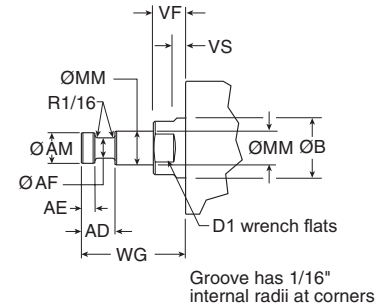

Thread Style 3 - "Special Thread"

Special threads, rod extensions, rod eyes, blanks, etc. are also available. To order, specify "Style 3" and give desired dimensions for KK or CC, A and W or WF. If otherwise special, please supply dimensioned sketch.

Rod End Dimensions

Bore size	Rod no.	Rod dia. MM	Thread																
			Style 8 CC	Style 4 & 9 KK	Style 6	A	AD	AE	AF	AM	B	C	D	D1	LAF	NA	VF	WF	WG
1-1/2	1	5/8	1/2 - 20	7/16 - 20	5/8 - 18	0.750	0.625	0.250	0.375	0.570	1.124	0.385	1/2	1	1.750	0.563	0.615	1.000	1.750
	2	1	7/8 - 14	3/4 - 16	1 - 14	1.125	0.938	0.375	0.688	0.950	1.499	0.510	7/8	1-3/8	2.500	0.938	0.865	1.375	2.375
2	1	5/8	1/2 - 20	7/16 - 20	5/8 - 18	0.750	0.625	0.250	0.375	0.570	1.124	0.385	1/2	1	1.750	0.563	0.615	1.000	1.750
	3	1	7/8 - 14	3/4 - 16	1 - 14	1.125	0.938	0.375	0.688	0.950	1.499	0.510	7/8	1-3/8	2.500	0.938	0.865	1.375	2.375
2-1/2	1	5/8	1/2 - 20	7/16 - 20	5/8 - 18	0.750	0.625	0.250	0.375	0.570	1.124	0.385	1/2	1	1.750	0.563	0.615	1.000	1.750
	3	1	7/8 - 14	3/4 - 16	1 - 14	1.125	0.938	0.375	0.688	0.950	1.499	0.510	7/8	1-3/8	2.500	0.938	0.865	1.375	2.375
3-1/4	1	1	7/8 - 14	3/4 - 16	1 - 14	1.125	0.938	0.375	0.688	0.950	1.499	0.510	7/8	1-3/8	2.500	0.938	0.865	1.375	2.375
	3	1-3/8	1-1/4 - 12	1 - 14	1 - 3/8 - 14	1.625	1.063	0.375	0.875	1.320	1.999	0.635	1-1/8	1-7/8	3.250	1.313	0.990	1.625	2.750
4	1	1	7/8 - 14	3/4 - 16	1 - 14	1.125	0.938	0.375	0.688	0.950	1.499	0.510	7/8	1-3/8	2.500	0.938	0.865	1.375	2.375
	3	1-3/8	1-1/4 - 12	1 - 14	1 - 3/8 - 14	1.625	1.063	0.375	0.875	1.320	1.999	0.635	1-1/8	1-7/8	3.250	1.313	0.990	1.625	2.750
5	1	1	7/8 - 14	3/4 - 16	1 - 14	1.125	0.938	0.375	0.688	0.950	1.499	0.510	7/8	1-3/8	2.500	0.938	0.865	1.375	2.375
	3	1-3/8	1-1/4 - 12	1 - 14	1 - 3/8 - 14	1.625	1.063	0.375	0.875	1.320	1.999	0.635	1-1/8	1-7/8	3.250	1.313	0.990	1.625	2.750



For inventory, lead times, and kit lookup, visit www.pdnplu.com

K-type Cylinder

To determine dimensions for a double rod end cylinder, first refer to the desired single rod end mounting style cylinder shown in this catalog section. After selecting the necessary dimensions from that drawing, return to this page and supplement the single rod end dimensions with those shown in the drawings and dimension table below. Note that double rod end cylinders have a head dimension G at both ends, and

Tie Rod Pneumatic Cylinders 4MA Series – 1-1/2" to 5" Bore Size

that LG replaces LF, P_k replaces P, etc. The double rod end dimensions differ from, or are in addition to, those for single rod cylinders.

When a double rod end cylinder has two different rod ends, please clearly state which rod end is to be available at which head end.

K-type for 1-1/2" to 5" Bore

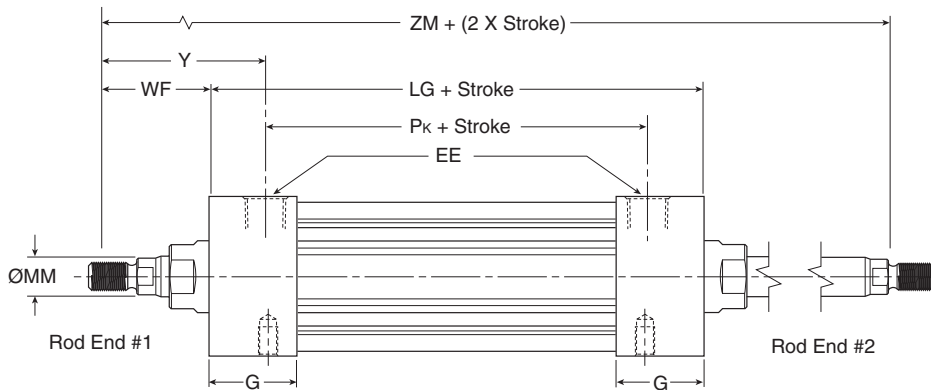

Mounting styles for single rod models	Corresponding mounting styles for double rod models
C	KC
CB	KCB
D	KD
DD	KDD
F	KF
G	KG
J	KJ
NB	KNB
T	KT
TB	KTB
TD	KTD
TE	KTE
TEF	KTEF

K-type Dimensions

Bore size	Rod no.	Rod dia. MM	Rod dia. EE (NPTF)	G	WF	Y	Add Stroke					Add 2X Stroke			
							LG	Pk	SAk	XAk	SSk	SNk	SEk	XEk	ZM
1-1/2	1	5/8	3/8	1.438	1.000	1.875	4.125	2.375	6.125	6.125	3.375	2.250	6.375	6.250	6.125
	2	1	3/8	1.438	1.375	2.250	4.125	2.375	6.500	6.500	3.375	-	-	-	5.760
2	1	5/8	3/8	1.375	1.000	1.875	4.125	2.375	6.125	6.125	3.375	2.250	6.750	6.438	6.125
	3	1	3/8	1.375	1.375	2.250	4.125	2.375	6.125	6.500	3.375	2.250	6.750	6.813	6.875
2-1/2	1	5/8	3/8	1.344	1.000	1.938	4.250	2.375	6.250	6.250	3.500	2.375	7.125	6.688	6.250
	3	1	3/8	1.344	1.375	2.313	4.250	2.375	6.250	6.625	3.500	2.375	7.125	7.063	7.000
3-1/4	1	1	1/2	1.594	1.375	2.438	4.750	2.625	7.250	7.375	3.750	2.625	7.750	7.625	7.500
	3	1-3/8	1/2	1.594	1.625	2.688	4.750	2.625	7.250	7.625	3.750	2.625	7.750	7.875	8.000
4	1	1	1/2	1.594	1.375	2.438	4.750	2.625	7.250	7.375	3.750	2.625	8.000	7.750	7.500
	3	1-3/8	1/2	1.594	1.625	2.688	4.750	2.625	7.250	7.625	3.750	2.625	8.000	8.000	8.000
5	1	1	1/2	1.594	1.375	2.438	4.938	2.813	7.688	7.688	3.563	2.813	-	-	7.688
	3	1-3/8	1/2	1.594	1.625	2.688	4.938	2.813	7.688	7.938	3.563	2.813	-	-	8.188
Replaces Dimension							LF	P	SA	XA	SS	SN	SE	XE	-
On Single Rod Mounting Styles							All Styles	All Styles	CB	CB	C	TEF, F	G	G	All

B

Tie Rod Pneumatic Cylinders

4MA Series

4MAJ Series

2MNR Series

ACVB Option

LPSO Option

P1D Series



For inventory, lead time, and kit lookup, visit www.pdnplu.com

Style J, H

**Tie Rod Pneumatic Cylinders
4MA/4ML Series – 1-1/2" to 5" Bore Size**

Head Rectangular Flange

Style J
(NFPA MF1)

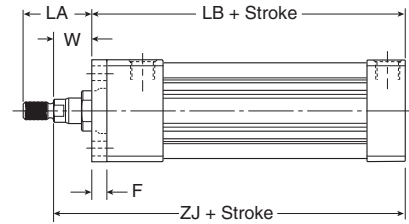
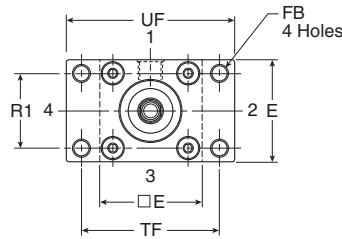
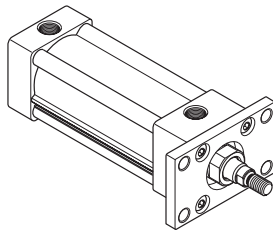

Note: Style J has a W dimension instead of WF and a LA dimension instead of LAF because of the flange installation. Please use dimensions W and LA regarding rod ends only for Style J.
For reference, WF = W + F and LA = W + A.

Cap Rectangular Flange

Style H
(NFPA MF2)

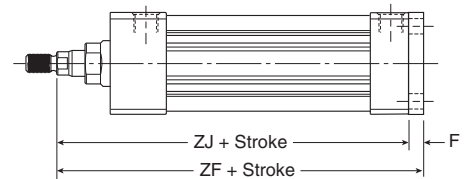
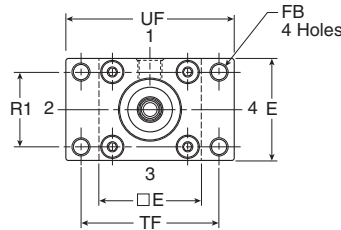
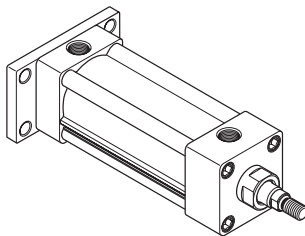

Styles J and H Dimensions

Bore size	Rod no.	Rod dia. MM	A	E	F	FB	LA	R1	TF	UF	W	Add stroke		
												LB	ZF	ZJ
1-1/2	1	5/8	0.750	2.000	0.375	0.313	1.375	1.430	2.750	3.375	0.625	4.000	5.000	4.625
	2	1	1.125	2.000	0.375	0.313	2.125	1.430	2.750	3.375	1.000	4.000	5.375	5.000
2	1	5/8	0.750	2.500	0.375	0.375	1.375	1.840	3.375	4.125	0.625	4.000	5.000	4.625
	3	1	1.125	2.500	0.375	0.375	2.125	1.840	3.375	4.125	1.000	4.000	5.375	5.000
2-1/2	1	5/8	0.750	3.000	0.375	0.375	1.375	2.190	3.875	4.625	0.625	4.125	5.125	4.750
	3	1	1.125	3.000	0.375	0.375	2.125	2.190	3.875	4.625	1.000	4.125	5.500	5.125
3-1/4	1	1	1.125	3.750	0.625	0.438	1.875	2.760	4.688	5.500	0.750	4.875	6.250	5.625
	3	1-3/8	1.625	3.750	0.625	0.438	2.625	2.760	4.688	5.500	1.000	4.875	6.500	5.875
4	1	1	1.125	4.500	0.625	0.438	1.875	3.320	5.438	6.250	0.750	4.875	6.250	5.625
	3	1-3/8	1.625	4.500	0.625	0.438	2.625	3.320	5.438	6.250	1.000	4.875	6.500	5.875
5	1	1	1.125	5.500	0.625	0.563	1.875	4.100	6.625	7.625	0.750	5.125	6.500	5.875
	3	1-3/8	1.625	5.500	0.625	0.563	2.625	4.100	6.625	7.625	1.000	5.125	6.750	6.125



For inventory, lead times, and kit lookup, visit www.pdnplu.com

B
 Tie Rod Pneumatic Cylinders
 4MA Series
 4MAJ Series
 2MNR Series
 ACVB Option
 LPSO Option
 P1D Series

Tie Rods Ext. Head End

Style TB
 (NFPA MX3)

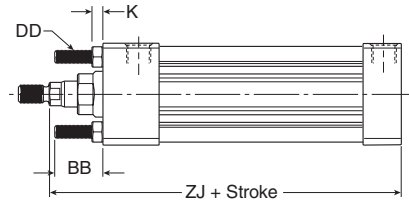
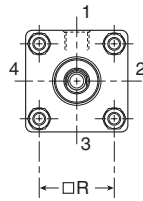
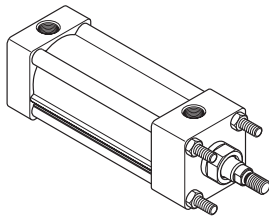

Tie Rods Ext. Cap End

Style TC
 (NFPA MX2)

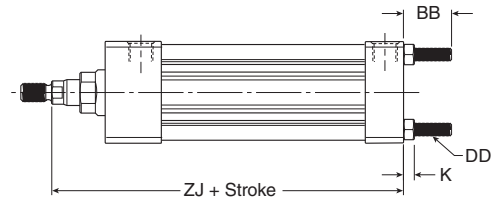
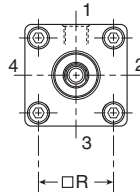
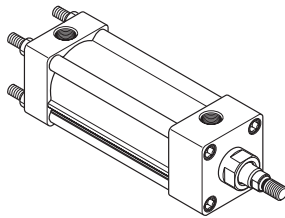

Tie Rods Ext. Both Ends

Style TD
 (NFPA MX1)

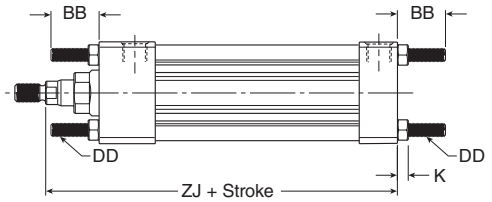
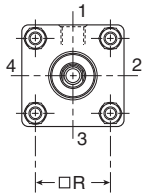
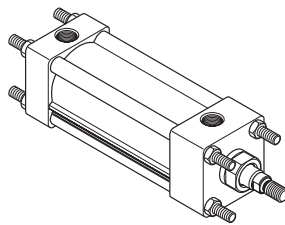

Styles TB, TC and TD Dimensions

Bore size	Rod no.	Rod dia. MM	BB	DD	E	K	R	Add stroke	
								ZJ	
1-1/2	1	5/8	1.000	1/4 - 28	2.000	0.250	1.430	4.625	
	2	1	1.000	1/4 - 28	2.000	0.250	1.430	5.000	
2	1	5/8	1.125	5/16 - 24	2.500	0.313	1.840	4.625	
	3	1	1.125	5/16 - 24	2.500	0.313	1.840	5.000	
2-1/2	1	5/8	1.125	5/16 - 24	3.000	0.313	2.190	4.750	
	3	1	1.125	5/16 - 24	3.000	0.313	2.190	5.125	
3-1/4	1	1	1.375	3/8 - 24	3.750	0.375	2.760	5.625	
	3	1-3/8	1.375	3/8 - 24	3.750	0.375	2.760	5.875	
4	1	1	1.375	3/8 - 24	4.500	0.375	3.320	5.625	
	3	1-3/8	1.375	3/8 - 24	4.500	0.375	3.320	5.875	
5	1	1	1.813	1/2 - 20	5.500	0.438	4.100	5.875	
	3	1-3/8	1.813	1/2 - 20	5.500	0.438	4.100	6.125	

B

Tie Rod Pneumatic Cylinders

4MA Series

4MAJ Series

2MNR Series

ACVB Option

LPSO Option

P1D Series



For inventory, lead time, and kit lookup, visit www.pdnplu.com

Style C, CB

**Tie Rod Pneumatic Cylinders
4MA/4ML Series – 1-1/2" to 5" Bore Size**

Side Lug

Style C for
(NFPA MS2)

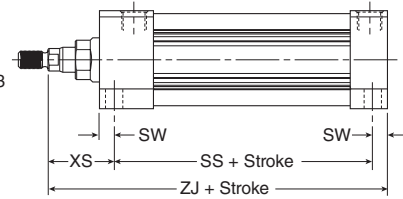
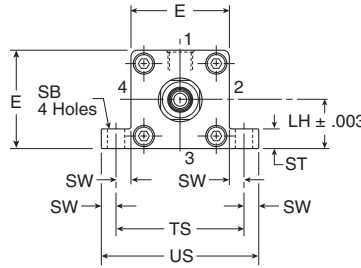
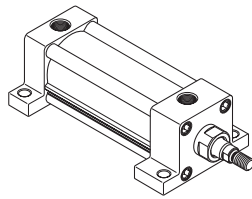

Style C Dimensions

Bore size	Rod no.	Rod dia. MM	E	LH	SB	ST	ST1	ST2	SW	SW1	TS	US	XS	Add stroke	
														SS	ZJ
1-1/2	1	5/8	2.000	0.993	0.438	0.500	1.000	0.120	0.375	0.495	2.750	3.500	1.375	2.875	4.625
	2	1	2.000	0.993	0.438	0.500	1.000	0.120	0.375	0.495	2.750	3.500	1.750	2.875	5.000
2	1	5/8	2.500	1.243	0.438	0.500	1.250	0.120	0.375	0.495	3.250	4.000	1.375	2.875	4.625
	3	1	2.500	1.243	0.438	0.500	1.250	0.120	0.375	0.495	3.250	4.000	1.750	2.875	5.000
2-1/2	1	5/8	3.000	1.493	0.438	0.500	1.343	0.120	0.375	0.495	3.750	4.500	1.375	3.000	4.750
	3	1	3.000	1.493	0.438	0.500	1.343	0.120	0.375	0.495	3.750	4.500	1.750	3.000	5.125
3-1/4	1	1	3.750	1.868	0.563	0.750	1.500	0.188	0.500	0.688	4.750	5.750	1.875	3.250	5.625
	3	1-3/8	3.750	1.868	0.563	0.750	1.500	0.188	0.500	0.688	4.750	5.750	2.125	3.250	5.875
4	1	1	4.500	2.243	0.563	0.750	1.500	0.188	0.500	0.688	5.500	6.500	1.875	3.250	5.625
	3	1-3/8	4.500	2.243	0.563	0.750	1.500	0.188	0.500	0.688	5.500	6.500	2.125	3.250	5.875
5	1	1	5.500	2.743	0.813	1.000	1.500	0.250	0.688	0.938	6.875	8.250	2.063	3.125	5.875
	3	1-3/8	5.500	2.743	0.813	1.000	1.500	0.250	0.688	0.938	6.875	8.250	2.313	3.125	6.125

Side End Angle

* Style CB
(NFPA MS1)

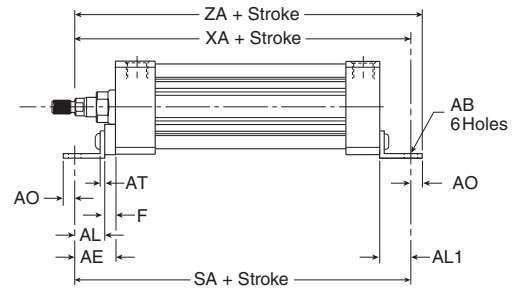
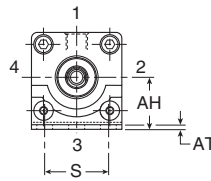
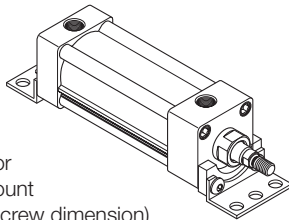

* Maximum recommended pressure for this mount is 150 PSIG.

Style CB Dimensions

Bore size	Rod no.	Rod dia. MM	AB	AE	AH	AL	AL1	AO	AT	E	F	S	Add stroke		
													SA	XA	ZA
1-1/2	1	5/8	0.438	1.375	1.188	1.000	1.000	0.375	0.125	2.000	0.375	1.250	6.000	5.625	6.000
	2	1	0.438	1.375	1.188	1.000	1.000	0.375	0.125	2.000	0.375	1.250	6.000	6.000	6.375
2	1	5/8	0.438	1.375	1.438	1.000	1.000	0.375	0.125	2.500	0.375	1.750	6.000	5.625	6.000
	3	1	0.438	1.375	1.438	1.000	1.000	0.375	0.125	2.500	0.375	1.750	6.000	6.000	6.375
2-1/2	1	5/8	0.438	1.375	1.625	1.000	1.000	0.375	0.125	3.000	0.375	2.250	6.125	5.750	6.125
	3	1	0.438	1.375	1.625	1.000	1.000	0.375	0.125	3.000	0.375	2.250	6.125	6.125	6.500
3-1/4	1	1	0.563	1.875	1.938	1.250	1.250	0.500	0.125	3.750	0.625	2.750	7.375	6.875	7.375
	3	1-3/8	0.563	1.875	1.938	1.250	1.250	0.500	0.125	3.750	0.625	2.750	7.375	7.125	7.625
4	1	1	0.563	-	2.250	1.875	1.250	0.500	0.125	4.500	-	3.500	7.375	6.875	7.375
	3	1-3/8	0.563	-	2.250	1.875	1.250	0.500	0.125	4.500	-	3.500	7.375	7.125	7.625
5	1	1	0.688	2.000	2.750	1.375	1.375	0.625	0.188	5.500	0.625	4.250	7.875	7.250	7.875
	3	1-3/8	0.688	2.000	2.750	1.375	1.375	0.625	0.188	5.500	0.625	4.250	7.875	7.500	8.125



For inventory, lead times, and kit lookup, visit www.pdnplu.com

Style G, NB

**Tie Rod Pneumatic Cylinders
4MA/4ML Series – 1-1/2" to 5" Bore Size**

Side End Lug

Style G
(NFPA MS7)

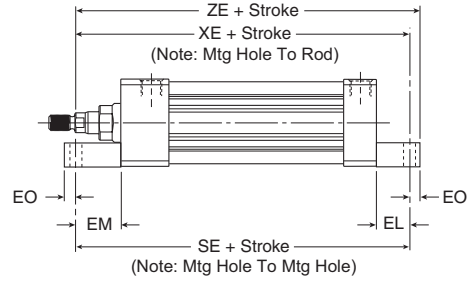
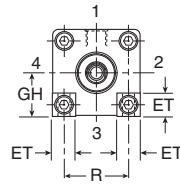
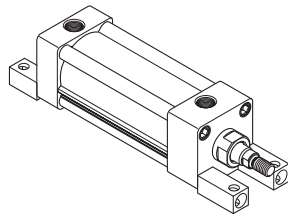

Style G Dimensions

Bore size	Rod no.	Rod dia. MM	E	EB	EL	EM	EO	ET	GH	R	Add Stroke		
											SE	XE	ZE
1-1/2	1	5/8	2.000	0.281	0.750	1.125	0.250	0.563	0.993	1.430	5.500	5.375	5.625
	2	1	-	-	-	-	-	-	-	-	-	-	-
2	1	5/8	2.500	0.344	0.938	1.313	0.313	0.688	1.243	1.840	5.875	5.563	5.875
	3	1	2.500	0.344	0.938	1.313	0.313	0.688	1.243	1.840	5.875	5.938	6.250
2-1/2	1	5/8	3.000	0.344	1.063	1.438	0.313	0.813	1.493	2.190	6.250	5.813	6.125
	3	1	3.000	0.344	1.063	1.438	0.313	0.813	1.493	2.190	6.250	6.188	6.500
3-1/4	1	1	3.750	0.406	0.875	1.500	0.375	1.000	1.868	2.760	6.625	6.500	6.875
	3	1-3/8	3.750	0.406	0.875	1.500	0.375	1.000	1.868	2.760	6.625	6.750	7.125
4	1	1	4.500	0.406	1.000	1.625	0.375	1.188	2.243	3.320	6.875	6.625	7.000
	3	1-3/8	4.500	0.406	1.000	1.625	0.375	1.188	2.243	3.320	6.875	6.875	7.250

Base Bar Mount

Style NB for 4MA

Note: Fasteners for NB base bar mount have been applied with removable thread locking compound and torqued to bottom of endcaps.

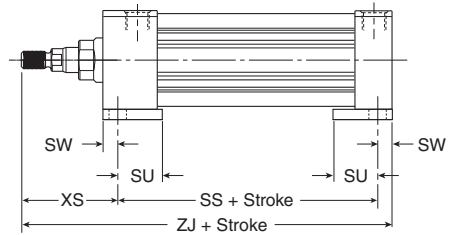
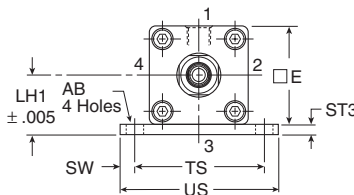
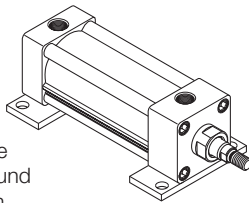

Style NB Dimensions

Bore size	Rod no.	Rod dia. MM	AB	E	LH1	ST3	SU	SW	TS	US	XS	Add stroke	
												SS	ZJ
1-1/2	1	5/8	0.438	2.000	1.243	0.250	1.125	0.375	2.750	3.500	1.375	2.875	4.625
	2	1	-	-	-	-	-	-	-	-	-	-	-
2	1	5/8	0.438	2.500	1.493	0.250	1.125	0.375	3.250	4.000	1.375	2.875	4.625
	3	1	0.438	2.500	1.493	0.250	1.125	0.375	3.250	4.000	1.750	2.875	5.000
2-1/2	1	5/8	0.438	3.000	1.868	0.375	1.125	0.375	3.750	4.500	1.375	3.000	4.750
	3	1	0.438	3.000	1.868	0.375	1.125	0.375	3.750	4.500	1.750	3.000	5.125
3-1/4	1	1	0.563	3.750	2.368	0.500	1.250	0.500	4.750	5.750	1.875	3.250	5.625
	3	1-3/8	0.563	3.750	2.368	0.500	1.250	0.500	4.750	5.750	2.125	3.250	5.875
4	1	1	0.563	4.500	2.743	0.500	1.250	0.500	5.500	6.500	1.875	3.250	5.625
	3	1-3/8	0.563	4.500	2.743	0.500	1.250	0.500	5.500	6.500	2.125	3.250	5.875

B

Tie Rod Pneumatic Cylinders

4MA Series

4MAJ Series

2MNR Series

ACVB Option

LPSO Option

P1D Series



For inventory, lead time, and kit lookup, visit www.pdnplu.com

B15

Parker Hannifin Corporation
Pneumatic Division
Richland, Michigan
www.parker.com/pneumatics

Cap Fixed Clevis

Style BB
 (NFPA MP1)

Note: For maximum swivel angle of BB mount with rear mounting plate, see cylinder accessories

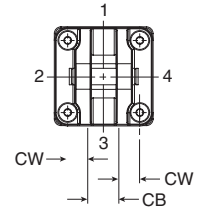
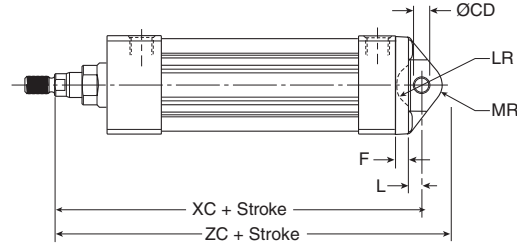
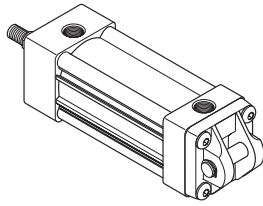

Cap Detachable Clevis

Style BC
 (NFPA MP2)

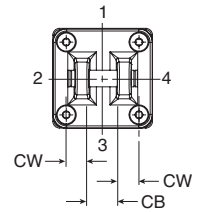
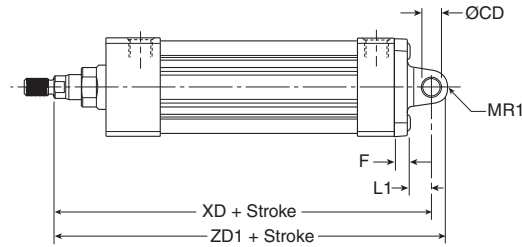
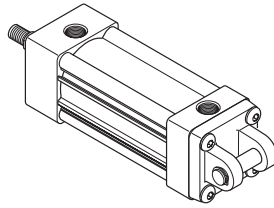

Cap Detachable Eye

Style BE
 (NFPA MP4)

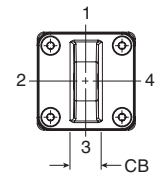
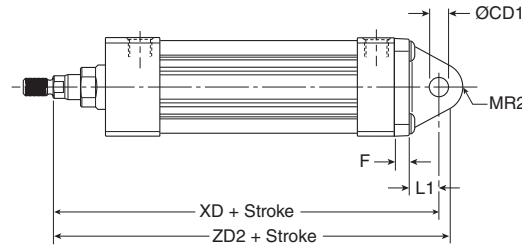
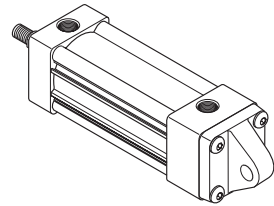

Styles BB, BC and BE Dimensions

Bore size	Rod no.	Rod dia. MM	CB	Rod dia.		CW	E*	F	L	LR	L1	MR	MR1	MR2	Add stroke				
				+0.000 -0.002	+0.002 +0.004										CD	CD1	XC	XD	ZC
1-1/2	1	5/8	0.750	0.501	0.500	0.500	2.000	0.375	0.375	0.750	0.750	0.625	0.500	0.625	5.375	5.750	6.000	6.250	6.375
	2	1	0.750	0.501	0.500	0.500	2.000	0.375	0.375	0.750	0.750	0.625	0.500	0.625	5.750	6.125	6.375	6.625	6.750
2	1	5/8	0.750	0.501	0.500	0.500	2.500	0.375	0.375	0.750	0.750	0.625	0.500	0.625	5.375	5.750	6.000	6.250	6.375
	3	1	0.750	0.501	0.500	0.500	2.500	0.375	0.375	0.750	0.750	0.625	0.500	0.625	5.750	6.125	6.375	6.625	6.750
2-1/2	1	5/8	0.750	0.501	0.500	0.500	3.000	0.375	0.375	0.750	0.750	0.625	0.500	0.688	5.500	5.875	6.125	6.375	6.563
	3	1	0.750	0.501	0.500	0.500	3.000	0.375	0.375	0.750	0.750	0.625	0.500	0.688	5.875	6.250	6.500	6.750	6.313
3-1/4	1	1	1.250	0.751	0.750	0.625	3.750	0.625	0.625	1.000	1.250	0.938	0.750	0.875	6.875	7.500	7.813	8.250	8.375
	3	1-3/8	1.250	0.751	0.750	0.625	3.750	0.625	0.625	1.000	1.250	0.938	0.750	0.875	7.125	7.750	8.063	8.500	8.625
4	1	1	1.250	0.751	0.750	0.625	4.500	0.625	0.625	1.000	1.250	0.938	0.750	0.875	6.875	7.500	7.813	8.250	8.375
	3	1-3/8	1.250	0.751	0.750	0.625	4.500	0.625	0.625	1.000	1.250	0.938	0.750	0.875	7.125	7.750	8.063	8.500	8.625
5	1	1	1.250	0.751	0.750	0.625	5.500	0.625	0.625	1.000	1.250	0.938	0.750	0.875	7.125	7.750	8.063	8.500	8.625
	3	1-3/8	1.250	0.751	0.750	0.625	5.500	0.625	0.625	1.000	1.250	0.938	0.750	0.875	7.375	8.000	8.313	8.750	8.875

* The 5" bore BB and BE bracket is the same as the 3-1/4" BB and BE bracket. The outer square dimension E is 3.75" and use SHCS.



For inventory, lead times, and kit lookup, visit www.pdnplu.com

B
 Tie Rod Pneumatic Cylinders
 4MA Series
 4MAJ Series
 2MNR Series
 ACVB Option
 LPSO Option
 P1D Series

Head Trunnion

* Style D
 (NFPA MT1)

Note: not available for 1-1/2" bore with 1" rod.

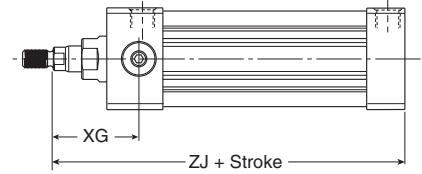
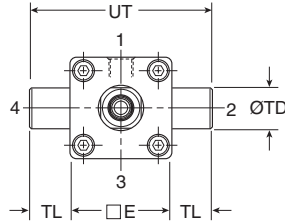
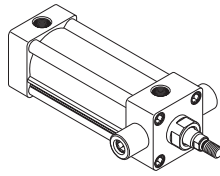

Cap Trunnion

Style DB
 (NFPA MT2)

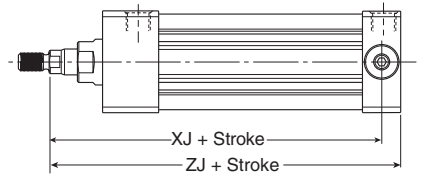
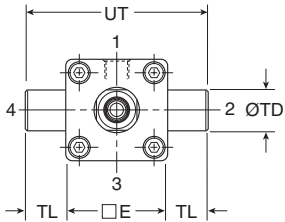
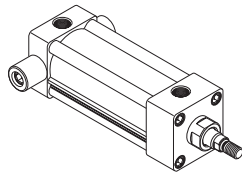

Intermediate Trunnion

Style DD
 (NFPA MT4)

Note: Tie rod nuts for Style DD have a slot instead of internal hex.

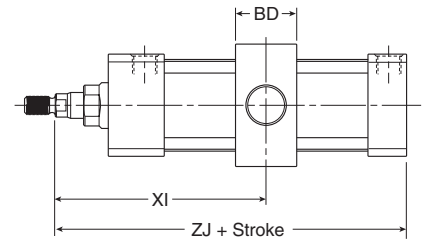
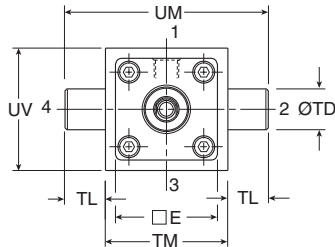
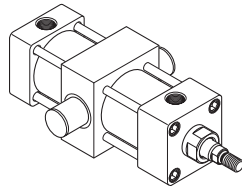

Note: Tie rod nuts for Style DD have a slot instead of internal hex.

Styles D, DB and DD Dimensions

Bore size	Rod no.	Rod dia. MM	E	BD	+0.001 -0.001 TD	TL	TM	UM	UT	UV	XG	Min. XI	Add stroke	
													XJ	ZJ
1-1/2	1	5/8	2.000	1.250	1.000	1.000	2.500	4.500	4.000	2.500	1.750	3.036	4.125	4.625
	2*	1	2.000	1.250	1.000	1.000	2.500	4.500	4.000	2.500	-	3.437	4.250	5.000
2	1	5/8	2.500	1.500	1.000	1.000	3.000	5.000	4.500	3.000	1.750	3.125	4.125	4.625
	3	1	2.500	1.500	1.000	1.000	3.000	5.000	4.500	3.000	2.125	3.500	4.500	5.000
2-1/2	1	5/8	3.000	1.500	1.000	1.000	3.500	5.500	5.000	3.500	1.750	3.094	4.250	4.750
	3	1	3.000	1.500	1.000	1.000	3.500	5.500	5.000	3.500	2.125	3.469	4.625	5.125
3-1/4	1	1	3.750	2.000	1.000	1.000	4.500	6.500	5.750	4.250	2.250	3.969	5.000	5.625
	3	1-3/8	3.750	2.000	1.000	1.000	4.500	6.500	5.750	4.250	2.500	4.219	5.250	5.875
4	1	1	4.500	2.000	1.000	1.000	5.250	7.250	6.500	5.000	2.250	3.969	5.000	5.625
	3	1-3/8	4.500	2.000	1.000	1.000	5.250	7.250	6.500	5.000	2.500	4.219	5.250	5.875
5	1	1	5.500	2.000	1.000	1.000	6.250	8.250	7.500	6.000	2.250	3.969	5.250	5.875
	3	1-3/8	5.500	2.000	1.000	1.000	6.250	8.250	7.500	6.000	2.500	4.219	5.500	6.125

* Head trunnion style D not available for 1-1/2" bore with 1" rod

Kits & Accessories

See page B34.



For inventory, lead time, and kit lookup, visit www.pdnplu.com

Features

4MA/4ML Series – 6" and 8" Bore Size

B	Tie Rod Pneumatic Cylinders
	4MA Series
	4MAJ Series
	2MNR Series
	ACVB Option
	LPSO Option
P1D Series	

PISTON SEALS (hidden)
 Carboxylated nitrile rounded-lip piston seals combine low friction with leak-free service and long service life.

PISTON ASSEMBLY (hidden)
 Aluminum piston with wear band increases service life and eliminates metal-to-metal contact. Optional magnetic piston ring for use with a variety of sensors. Anaerobic adhesive is used to permanently lock and seal the piston to the rod.

HEADS AND CAPS
 High-strength aluminum heads and caps are anodized for corrosion resistance. We can offer customization of the endcaps for unique designs, including extra ports, duplex, tandem and many special mountings.

PISTON ROD
 Standard case-hardened (50-64 Rc), hard chrome plated and polished carbon steel piston rod for reliable performance, long rod seal life and low friction. Grades of stainless steel are available as options.

PORTS
 NPTF ports are standard. Other port styles available.

ADJUSTABLE CUSHIONS available

ROD GLAND/BEARING
 Threaded bronze rod gland is externally removable, without cylinder disassembly, for easy maintenance. Machined flats permit the use of common tools for removal and installation. Options include HI LOAD design for side load conditions and metallic wiper design for extremely tough rod contaminant/adherent applications.

TIE ROD CONSTRUCTION
 Steel tie rods and nuts for heavy-duty use. Stainless steel is available as an option.

ROD SEAL (hidden)
 Carboxylated nitrile rounded-lip rod seal combines low friction with leak-free service and long service life.

ROD WIPER
 Outboard urethane rod wiper protects the cylinder by removing external debris and adherents from the piston rod during the entire stroke.

CYLINDER BODY
 Hard anodized aluminum for corrosion resistance, maximum seal life and lower friction.

For a complete list of 4MA options, please see pages B19 and B23.



For inventory, lead times, and kit lookup, visit www.pdnplu.com

Features

- Industry leading NFPA interchangeable cylinder with flexible construction
- Bore sizes – 6" and 8"
- Removable bronze alloy gland/bearing for easy maintenance
- Available in any practical stroke length
- Tube and tie rod construction for heavy duty use
- Single rod end or double rod ends
- Cushions – optional and adjustable at either end or both ends (N/A for 4ML hydraulic version)
- 20 standard mounting styles available
- RoHS compliant

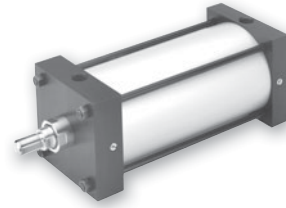

Operating information

	4MA	4ML
Operating pressure:	250 PSIG (17 bar) maximum air service	400 PSIG (27 bar) maximum hydraulic service
Temperature range –		
Standard seals	-10°F to 165°F (-23°C to 74°C)	
Fluorocarbon seals	-10°F to 250°F (-23°C to 121°C)	
Low temperature seals	-50°F to 150°F (-46°C to 66°C)	
Filtration requirements:	40 micron, dry filtered air	Filtered hydraulic oil

Ordering information

6.00		J	4MA		U		1	4		A		12.000
Bore size		Double rod cylinder	Series		Ports		Piston rod number			Cushion cap end		Stroke length
6.00		Specify "K" only if double rod cylinder is required.	4MA Air service 4ML Hydraulic service		U NPTF R BSPP B BSPT T SAE		Specify rod code number for required diameter. ^{8,2}			Blank Non-cushioned cap end C Cushioned cap end (not available for 4ML)		Specify stroke length required in inches. ⁸
8.00		Mounting style					Special modification			Piston rod thread type		
		Specify mounting style code (see table on following page).					Specify "S" only for special modification other than rod end, and then describe modification in item notes. (Includes 4MA with Linear Position Sensor Option) ⁷			A Standard (UNF unified thread) W BSF British fine M* Metric		
		Cushion head end								* Please reference page B78.		
		Blank Non-cushioned head end C Cushioned head end (not available for 4ML)								Seals		
		Piston type								Blank Standard (nitrile seals) V Fluorocarbon seals ¹ E Fluorocarbon rod wiper and rod seal only ² 4 Low temperature seals ¹ M Metallic rod wiper, nitrile seals ³		
		Blank Standard (lipseals and no magnetic ring) 3 Lipseals and magnetic ring								Piston rod thread style		
										4 Small male 8 Intermediate male 9 Short female 55 For use with split coupler ⁶ 3 Special (and specify all dimensions required) 6 Full male		
										Rod material and gland code		
										Blank Standard rod and gland H Standard rod and HI LOAD gland Y 17-4 PH stainless steel rod and standard gland Z 17-4 PH stainless steel rod and HI LOAD gland J 303 stainless steel rod and standard gland ⁷ K 303 stainless steel rod and HI LOAD gland ⁷ S 316 stainless steel rod and standard gland ⁷ T 316 stainless steel rod and HI LOAD gland ⁷		

Sensors
See section L for sensors.

¹ Reed and solid-state sensors only available with standard seals or options E and M.
² Used for external chemical compatibility applications, not high temperature.
³ If fluorocarbon seals are required with this option, please place an "S" for special in the Special Modification field and specify the "fluorocarbon seals and metallic rod wiper" in the item notes.
⁴ For Linear Position Sensor Option (LPSO), please include the following information for the Special Modification item notes:
 a. Sensor part number (please reference pages B72-B76)
 b. Sensor position
 c. Port position (if other than position 1)
 d. Length of stop tubing, gross stroke and net stroke (if required)
 Also, Piston Type 3 is required.
⁵ Review Piston Rod Selection Chart, please reference page A14 to determine proper piston rod diameter.
⁶ For additional information regarding this style, please reference page B77. If non-standard Rod Material and Gland Code is required with this option, please place an "S" for special in Special Modification field and specify Rod Material and Gland Code in the item notes.
⁷ Not available for 4ML.
⁸ If a stop tube is required, specify gross stroke (net stroke + stop tube) in the model number, then place an "S" for special in the Special Modification field and specify the stop tube length in the item notes.

For ordering purposes, when special options or common modifications are requested, the factory will assign a sequential part number in place of the model number.



For inventory, lead time, and kit lookup, visit www.pdnplu.com

4MA/4ML Mounting Styles for 6" & 8" Bore

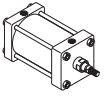
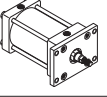
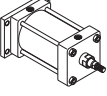
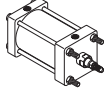
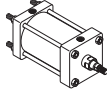
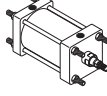
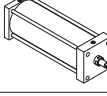
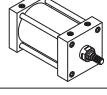
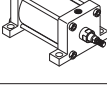
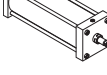
Mounting style	NFPA mounting	Description	Bore size
T 	MX0	No Mount	6 - 8
J 	MF1	Head Rectangular Flange	6
H 	MF2	Cap Rectangular Flange	6
TB 	MX3	Tie Rods Extended Head End	6 - 8
TC 	MX2	Tie Rods Extended Cap End	6 - 8
TD 	MX1	Tie Rods Extended Both Ends	6 - 8
TE 	MX5	Sleeve Nut	6 - 8
TEF 	MX5/MS4	Sleeve Nut with Side Tap	6 - 8
C 	MS2	Side Lug	6 - 8
F 	MS4	Side Tap	6 - 8

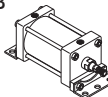
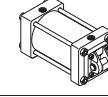
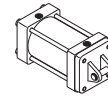
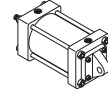
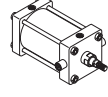
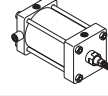
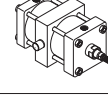
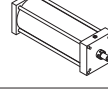
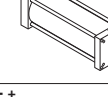
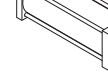
Mounting style	NFPA mounting	Description	Bore size
CB 	MS1	Side End Angle	6 - 8
BB 	MP1	Cap Fixed Clevis	6 - 8
BC 	MP2	Cap Detachable Clevis	6 - 8
BE 	MP4	Cap Detachable Eye	6
D 	MT1	Head Trunnion	6 - 8
DB 	MT2	Cap Trunnion	6 - 8
DD 	MT4	Intermediate Trunnion	6 - 8
JB 	ME3	Head Square	8
HB 	ME4	Cap Square	8
KT † 	MDX0	Double Rod End, No Mount	6 - 8

† Double rod end cylinders can be ordered with head mountings, i.e. KJ.

B
 Tie Rod Pneumatic Cylinders
 4MA Series
 4MAJ Series
 2MNR Series
 ACVB Option
 LPS0 Option
 P1D Series



For inventory, lead times, and kit lookup, visit www.pdnplu.com

Specifications

Tie Rod Pneumatic Cylinders 4MA/4ML Series – 6” and 8” Bore Size

General Specifications

- NFPA interchangeable
 - Bore sizes – 6" and 8"
 - Strokes – available in any practical stroke length
 - Rod diameters – 1-3/8" and 1-3/4"
 - Rod end styles – 4 standard, specials available
 - Single rod end or double rod ends
 - Cushions – optional and adjustable at either end or both ends (N/A for 4ML Hydraulic Version)
 - Operating pressure –
4MA = 250 PSIG (17 Bar) maximum air service
4ML = 400 PSIG (27 Bar) maximum hydraulic service
 - Media – 4MA = dry, filtered air
4ML = filtered hydraulic oil
 - Temperature range –
-10°F to 165°F (-23°C to 74°C) standard seals
-10°F to 250°F (-23°C to 121°C) fluorocarbon seals option
-50°F to 150°F (-46°C to 66°C) low temperature seals option
 - Mounting styles – 20 standard styles
 - RoHS compliant
- For material options, including seals, piston rods and glands, please see Material Specifications on next page.

Cylinder Weights

Bore (inch)	Rod (inch)	No mount single rod 4MA/4ML		No mount double rod	
		Base wt. (lbs.)	Per inch (lbs.)	Base wt. (lbs.)	Per inch (lbs.)
6	1.375	20.50	0.87	25.65	1.30
	1.75	22.61	1.13	30.41	1.82
8	1.375	35.50	1.25	41.15	1.68
	1.75	37.63	1.51	45.90	2.20

Mounting Weight Adders

Bore (inch)	Mounting style, weight (lbs)							
	J, H	D, DB	BB	CB	DD	BE	C	BC
6	10.74	1.22	2.91	5.88	15.52	2.91	0.69	11.38
8	N/A	1.22	2.91	7.84	25.01	N/A	0.67	17.31

Standard Cushion Position

Mounting Code	Position
All except D, DB, DD	2
D, DB, DD	3

Standard Port Sizes

Bore	NPTF	BSPT	BSPP	SAE
6	3/4	Rc3/4	G3/4	12
8	3/4	Rc3/4	G3/4	12

B

Tie Rod Pneumatic Cylinders

4MA Series

4MAJ Series

2MNR Series

ACVB Option

LPSO Option

P1D Series



For inventory, lead time, and kit lookup, visit www.pdnplu.com

B21

Parker Hannifin Corporation
Pneumatic Division
Richland, Michigan
www.parker.com/pneumatics

Material Specifications

Standard Temperatures and Applications

Head and cap	Black anodized aluminum alloy
Cylinder body	Clear hard-coat anodized aluminum alloy
Piston rod	Case-hardened, chrome plated carbon steel
Rod seal	Carboxylated nitrile (Nitroxile)
Rod wiper	Molythane
Rod bearing (gland)	Bronze alloy
Piston	Aluminum alloy
Piston seals	Carboxylated nitrile (Nitroxile)
Piston bearing	MolyGard™
Magnetic ring	Plastic-bound magnetic material
Piston fastener	Piston rod for aluminum piston
O-rings	Nitrile
End seals	Nitrile
Cushion seals	Urethane
Cushion needle valves	Brass cushion needle valves
Tie-rods	Blackened carbon steel
Tie-rod nuts	Steel alloy, SAE J995 Grade 8

Tie Rod Pneumatic Cylinders 4MA/4ML Series – 6” and 8” Bore Size

Material and Part Changes

4MA Options

High temperatures (-10°F to 250°F)	All seals and wiper are fluorocarbon Aluminum piston without magnetic ring
Low temperatures (-50°F to 150°F)	Rod seal, piston seals, o-rings and end seals are low temperature-rated nitrile

4ML Hydraulic Version

Hydraulic service (general)	Cushions not available
Hydraulic service (std temp)	Polyurethane TS-2000 rod seal and nitrile piston seals (for hydraulic use)
Hydraulic service (high temp)	Fluorocarbon TS-2000 rod seal; wiper and all seals are fluorocarbon (for hydraulic use)

Other Standard Options

Cylinder seal options	Fluorocarbon for high temperatures or chemical compatibility Other seal options available, please consult factory
Piston rod material options	Case-hardened, chrome plated carbon steel (standard) 17-4 PH stainless steel, chrome plated 303 stainless steel, chrome plated (N/A for 4ML) 316 stainless steel, chrome plated (N/A for 4ML) For stainless steel without chrome plating, please consult factory
HI LOAD gland option	Composite bearing pressed into bronze alloy gland
Metallic rod scraper option	Dual high strength bronze wipers with fluorocarbon energizer

B	Tie Rod Pneumatic Cylinders		
			4MA Series
			4MAJ Series
			2MNR Series
			ACVB Option
			LPSO Option
			P1D Series



For inventory, lead times, and kit lookup, visit www.pdnplu.com

How to Select a 6” - 8” Bore 4MA Cylinder

Parker cylinders are available based on air or hydraulic operating pressure. The many styles, sizes and optional features available assure that your application requirements are precisely met. To select a cylinder, follow these simple steps:

- Step 1 - **Determine the correct cylinder bore size** necessary to achieve required force using the available operating pressure.
- Step 2 - **Determine the series cylinder to use**, based on operating pressure.
- Step 3 - **Turn to the appropriate cylinder selection section.** Select the mounting style that fits your installation needs. Determine the bore and rod sizes available for the model you select. Then complete model selection.
 - Choose a rod end style and the desired rod end accessories.
 - Size the cylinder to meet your application requirements.
- Step 4 - **Consider the following conditions** which may require further modifications to the cylinder you have selected.

Application Condition	Check the Following
Quick Starts or Stops	Confirm that determined thrust is sufficient to accelerate or decelerate cylinder and load within prescribed distance. Optional cushions should be used to reduce shock during deceleration, check that peak pressures will be within tolerable limits.
Long Push Stroke	Check whether stop tube is required to prevent excessive bearing loads and wear.
High-column Loading Long Push Stroke	Determine if standard size piston rod is strong enough to accommodate intended load. See Application Engineering section for recommendations.
Long Horizontal Stroke	Determine if standard size piston rod is strong enough to accommodate intended load.
High Operating Temperatures	For temperatures between 165°F and 250°F use 4MA cylinder with high temperature seals.

General Options and Modifications:

- Adjustable Cushions
- Magnetic Piston
- Port and Adjustable Cushion Relocation
- Port Thread Styles
- Multiple Ports
- Special Heads, Caps, Pistons and Mounts
- Double Rod End
- Oversize Rod Diameters
- Rod End Modifications
- Rod Materials (grades of stainless steel)
- Stainless Steel Tie Rods and Nuts
- Fluorocarbon Rod Wiper and Rod Seal only
- Fluorocarbon Seals (all cylinder seals)
- Metallic Rod Wiper
- HI LOAD Gland Assembly
- Stop Tube
- Mixed Mountings
- Shock Absorber on Cap End
- Air Cylinder/Valve Combination (ACVB)
- Adjustable Point Sensors (order separately)
- Continuous Linear Position Sensing (LPSO)
- High Temperature Service (to 250°F)
- Low Temperature Service (to -50°F)
- Hydraulic Service (4ML) (400 PSIG)
- Rod lock version (see 4MAJ)

B
Tie Rod Pneumatic Cylinders
4MA Series
4MAJ Series
2MNR Series
ACVB Option
LPSO Option
P1D Series



For inventory, lead time, and kit lookup, visit www.pdnplu.com

Style T

**Tie Rod Pneumatic Cylinders
4MA/4ML Series – 6” and 8” Bore Size**

**Single Rod
(Style T)**

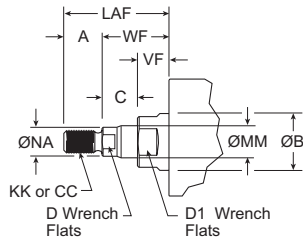
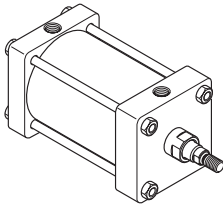

For dimensions of all standard rod end styles, please see next page.

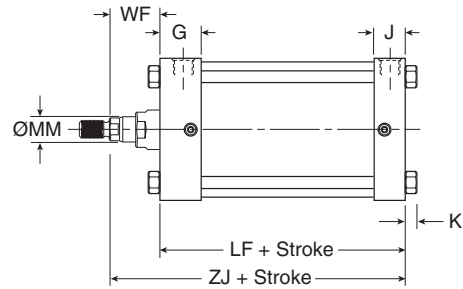
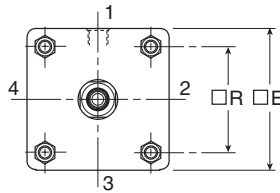
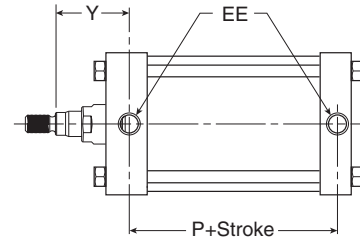

Style T Dimensions

Bore size	Rod no.	Rod dia. MM	Thread			A	AA	B	C	D	D1	E	EE (NPTF)	G
			Style 8 CC	Style 4 & 9 KK	Style 6									
6	1	1-3/8	1-1/4 - 12	1-14	1-3/8 - 14	1.625	6.900	1.999	0.635	1-1/8	1-7/8	6.500	3/4	1.910
	3	1-3/4	1-1/2 - 12	1-1/4 - 12	1-3/4 - 12	2.000	6.900	2.374	0.760	1-1/2	2-3/16	6.500	3/4	1.910
8	1	1-3/8	1-1/4 - 12	1-14	1-3/8 - 14	1.625	9.100	1.999	0.635	1-1/8	1-7/8	8.500	3/4	1.810
	3	1-3/4	1-1/2 - 12	1-1/4 - 12	1-3/4 - 12	2.000	9.100	2.374	0.760	1-1/2	2-3/16	8.500	3/4	1.810

Bore size	Rod no.	Rod dia. MM	Add stroke										
			J	K	LAF	NA	R	VF	WF	Y	LF	P	ZJ
6	1	1-3/8	1.410	0.438	3.250	1.313	4.880	0.990	1.625	2.813	5.000	3.125	6.625
	3	1-3/4	1.410	0.438	3.875	1.688	4.880	1.115	1.875	3.063	5.000	3.125	6.875
8	1	1-3/8	1.440	0.563	3.250	1.313	6.440	0.990	1.625	2.750	5.125	3.250	6.750
	3	1-3/4	1.440	0.563	3.875	1.688	6.440	1.115	1.875	3.000	5.125	3.250	7.000

B
Tie Rod Pneumatic Cylinders

4MA Series

4MAJ Series

2MNR Series

ACVB Option

LPSO Option

P1D Series



For inventory, lead times, and kit lookup, visit www.pdnplu.com

Rod End Thread Styles

Tie Rod Pneumatic Cylinders 4MA/4ML Series – 6” and 8” Bore Size

Rod End

Thread Style 4
(NFPA Style SM)
Small Male

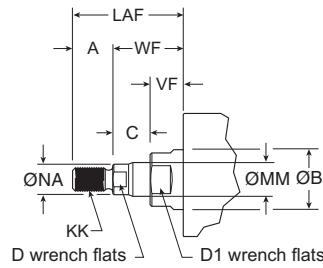

Thread Style 8
(NFPA Style IM)
Intermediate Male

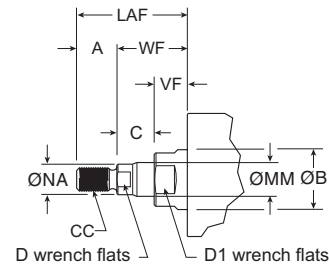

Thread Style 9
(NFPA Style SF)
Short Female

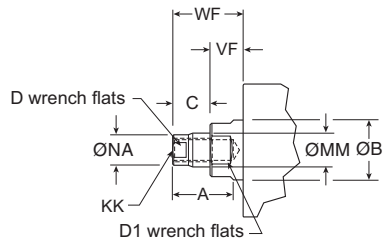

Thread Style 55
For use with Split Coupler
(please reference page B77 for more information)

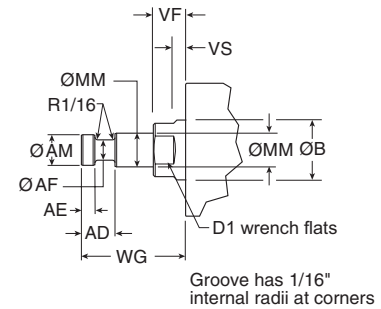

Thread Style 3 - "Special Thread"

Special threads, rod extensions, rod eyes, blanks, etc. are also available. To order, specify "Style 3" and give desired dimensions for KK or CC, A and W or WF. If otherwise special, please supply dimensioned sketch.

Rod End Dimensions

Bore size	Rod no.	Rod dia. MM	Thread		Style 6	A	AD	AE	AF	AM	B	C	D	D1	LAF	NA	VF	WF	WG
			Style 8 CC	Style 4 & 9 KK															
6	1	1-3/8	1-1/4 - 12	1 - 14	1-3/8 - 14	1.625	1.063	0.375	0.875	1.320	1.999	0.635	1-1/8	1-7/8	3.250	1.313	0.990	1.625	2.750
	3	1-3/4	1-1/2 - 12	1-1/4 - 12	1-3/4 - 12	2.000	1.313	0.500	1.125	1.700	2.374	0.760	1-1/2	2-3/16	3.875	1.688	1.115	1.875	3.125
8	1	1-3/8	1-1/4 - 12	1 - 14	1-3/8 - 14	1.625	1.063	0.375	0.875	1.320	1.999	0.635	1-1/8	1-7/8	3.250	1.313	0.990	1.625	2.750
	3	1-3/4	1-1/2 - 12	1-1/4 - 12	1-3/4 - 12	2.000	1.313	0.500	1.125	1.700	2.374	0.760	1-1/2	2-3/16	3.875	1.688	1.115	1.875	3.125

B

Tie Rod Pneumatic Cylinders

4MA Series

4MAJ Series

2MNR Series

ACVB Option

LPSO Option

P1D Series



For inventory, lead time, and kit lookup, visit www.pdnplu.com

To determine dimensions for a double rod end cylinder, first refer to the desired single rod end mounting style cylinder shown in this catalog section. After selecting the necessary dimensions from that drawing, return to this page and supplement the single rod end dimensions with those shown in the drawings and dimension table below. Note that double rod end cylinders have a head dimension G at both ends, and

that LG replaces LF, PK replaces P, etc. The double rod end dimensions differ from, or are in addition to, those for single rod cylinders.

When a double rod end cylinder has two different rod ends, please clearly state which rod end is to be available at which head end.

K-type for 6” & 8” bore

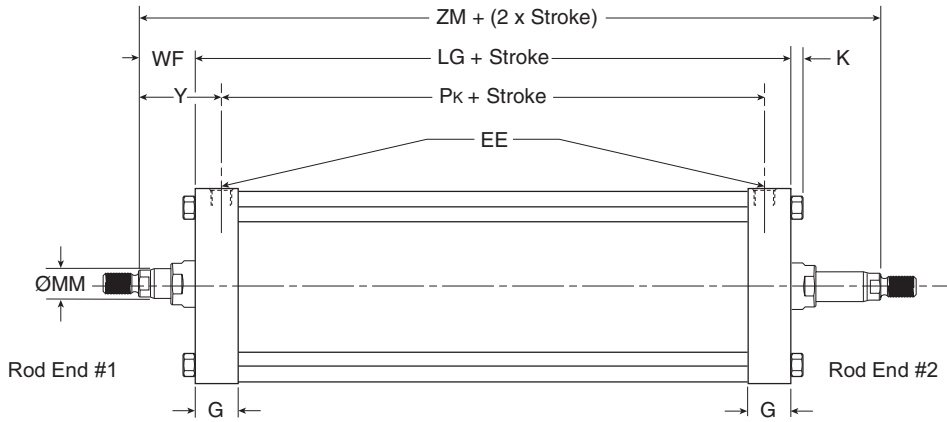

Mounting styles for single rod models	Corresponding mounting styles for double rod models
C	KC
CB	KCB
D	KD
DD	KDD
F	KF
J	KJ
T	KT
TB	KTB
TD	KTD
TE	KTE
TEF	KTEF

Style KT Dimensions

Bore size	Rod no.	Rod dia. MM	EE (NPTF) G	K	WF	Y	Add stroke						Add 2X stroke ZM		
							LG	Pk	SAk	XAk	SSk	SNk			
6	1	1-3/8	3/4	1.910	0.438	1.625	2.813	5.500	3.125	8.250	8.500	4.125	3.125	8.750	
	3	1-3/4	3/4	1.910	0.438	1.875	3.063	5.500	3.125	8.250	8.750	4.125	3.125	9.250	
8	1	1-3/8	3/4	1.810	0.563	1.625	2.750	5.500	3.250	9.125	8.938	4.125	3.125	8.750	
	3	1-3/4	3/4	1.810	0.563	1.875	3.000	5.500	3.250	9.125	9.188	4.125	3.125	9.250	
								Replaces Dimension	LF	P	SA	XA	SS	SN	-
								On Single Rod Mounting Styles	All Styles	All Styles	CB	CB	C	F, TEF	All

B
 Tie Rod Pneumatic Cylinders
 4MA Series
 4MAJ Series
 2MNR Series
 ACVB Option
 LPSO Option
 P1D Series



For inventory, lead times, and kit lookup, visit www.pdnplu.com

Style J, H

Tie Rod Pneumatic Cylinders 4MA/4ML Series – 6” and 8” Bore Size

Head Rectangular Flange

Style J
(NFFA MF1)
(only 6" Bore)

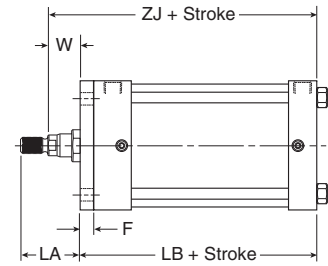
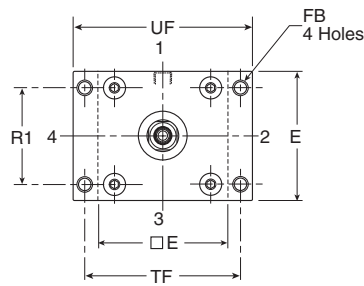
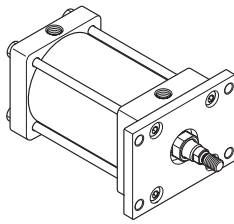

Note: Style J has a W dimension instead of WF and a LA dimension instead of LAF because of the flange installation. Please use dimensions W and LA regarding rod ends only for Style J. For reference, $WF = W + F$ and $LA = W + A$.

Cap Rectangular Flange

Style H
(NFFA MF2)
(only 6" Bore)

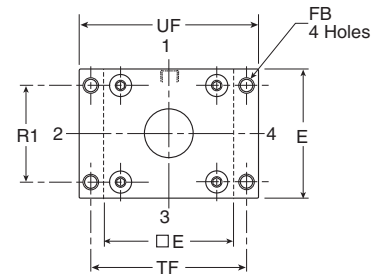
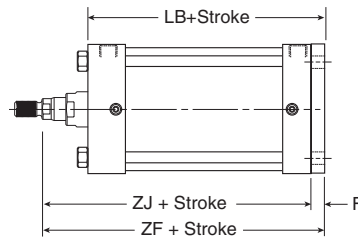
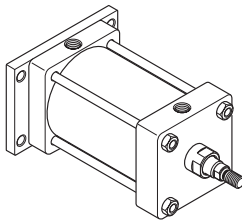

Styles J and H Dimensions

Bore size	Rod no.	Rod dia. MM	A	E	F	FB	LA	R1	TF	UF	W	Add stroke		
												LB	ZF	ZJ
6	1	1-3/8	1.625	6.500	0.750	0.563	2.500	4.880	7.625	8.625	0.875	5.750	7.375	6.625
	3	1-3/4	2.000	6.500	0.750	0.563	3.125	4.880	7.625	8.625	1.125	5.750	7.625	6.875

B
Tie Rod Pneumatic Cylinders
4MA Series
4MAJ Series
2MNR Series
ACVB Option
LPSO Option
P1D Series



For inventory, lead time, and kit lookup, visit www.pdnplu.com

Tie Rods Ext. Head End

Style TB
 (NFPA MX3)

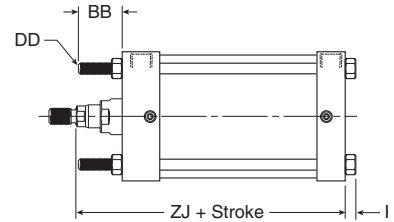
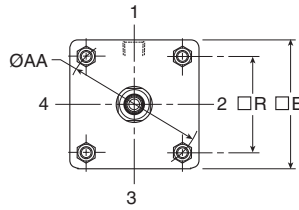
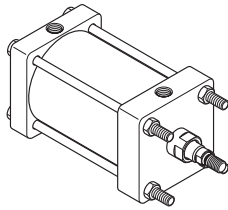

Tie Rods Ext. Cap End

Style TC
 (NFPA MX2)

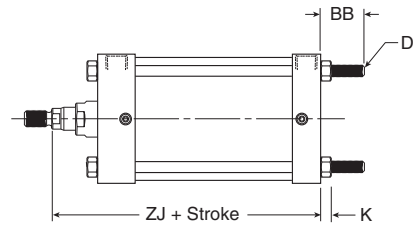
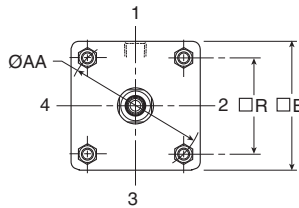
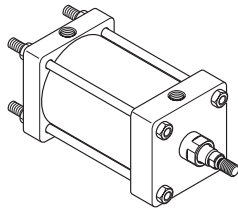

Tie Rods Ext. Both Ends

Style TD
 (NFPA MX1)

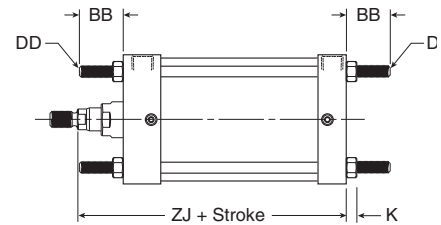
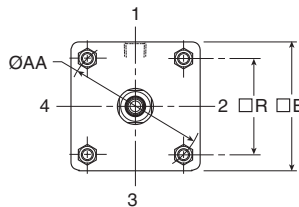
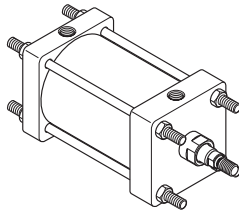

Styles TB, TC and TD Dimensions

Bore size	Rod no.	Rod dia. MM	AA	BB	DD	E	K	R	Add stroke
									ZJ
6	1	1-3/8	6.900	1.813	1/2-20	6.500	0.438	4.880	6.625
	3	1-3/4	6.900	1.813	1/2-20	6.500	0.438	4.880	6.875
8	1	1-3/8	9.100	2.313	5/8-18	8.500	0.563	6.440	6.750
	3	1-3/4	9.100	2.313	5/8-18	8.500	0.563	6.440	7.000

B Tie Rod Pneumatic Cylinders

4MA Series

4MAJ Series

2MNR Series

ACVB Option

LPSO Option

P1D Series



For inventory, lead times, and kit lookup, visit www.pdnplu.com

Sleeve Nut
 Style TE
 (NFPA MX5)

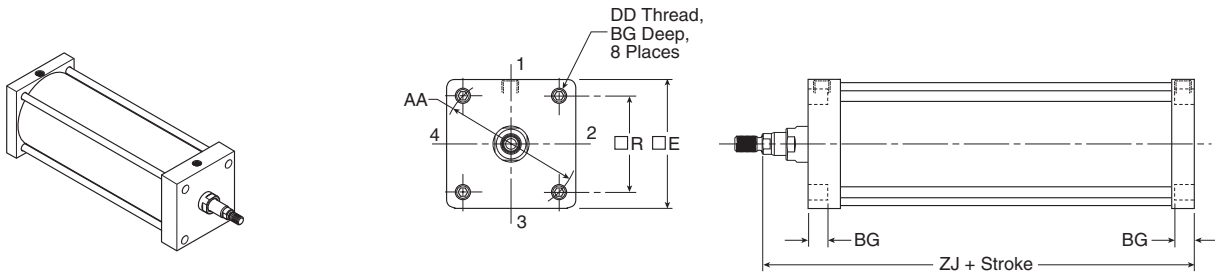

Style TE Dimensions

Bore size	Rod no.	Rod dia. MM	AA	BG	DD	E	R	Add stroke
								ZJ
6	1	1-3/8	6.900	0.500	1/2-20	6.500	4.880	6.625
	3	1-3/4	6.900	0.500	1/2-20	6.500	4.880	6.875
8	1	1-3/8	9.100	0.620	5/8-18	8.500	6.440	6.750
	3	1-3/4	9.100	0.620	5/8-18	8.500	6.440	7.000

Side End Angle

* Style CB
 (NFPA MS1)

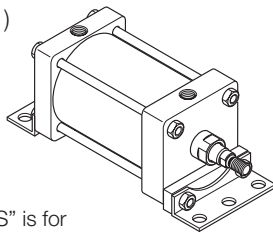

Note:
 Dimension "S" is for the holes in the mount (not the screw to screw dimension)

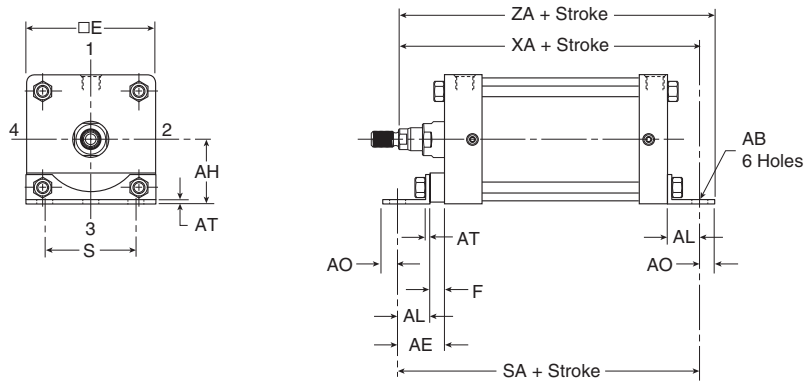

*Maximum recommended pressure for this mount is 150 PSIG

Style CB Dimensions

Bore size	Rod no.	Rod dia. MM	AB	AE	AH	AL	AO	AT	E	F	S	Add stroke		
												SA	XA	ZA
6	1	1-3/8	0.813	2.125	3.250	1.375	0.625	0.188	6.500	0.750	5.250	8.500	8.000	8.625
	3	1-3/4	0.813	2.125	3.250	1.375	0.625	0.188	6.500	0.750	5.250	8.500	8.250	8.875
8	1	1-3/8	0.813	1.813	4.250	1.813	0.688	0.250	8.500	-	7.125	8.750	8.563	9.250
	3	1-3/4	0.813	1.813	4.250	1.813	0.688	0.250	8.500	-	7.125	8.750	8.813	9.500

B	Tie Rod Pneumatic Cylinders
	4MA Series
4MAJ Series	
2MNR Series	
ACVB Option	
LPSO Option	
P1D Series	

Style C, F

**Tie Rod Pneumatic Cylinders
4MA/4ML Series – 6” and 8” Bore Size**

Side Lug

Style C
(NFPA MS2)

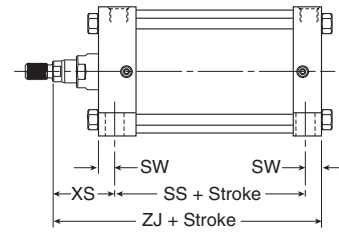
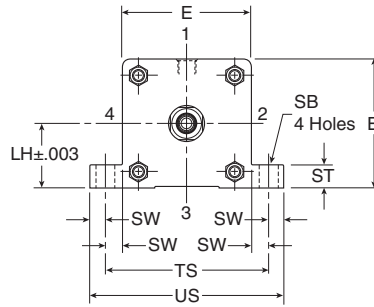
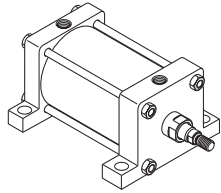

Style C Dimensions

Bore size	Rod no.	Rod dia. MM	E	+/- .003 LH	SB	ST	SW	TS	US	XS	Add stroke	
											SS	ZJ
6	1	1-3/8	6.500	3.243	0.813	1.000	0.688	7.875	9.250	2.313	3.625	6.625
	3	1-3/4	6.500	3.243	0.813	1.000	0.688	7.875	9.250	2.563	3.625	6.875
8	1	1-3/8	8.500	4.243	0.813	1.000	0.688	9.875	11.250	2.313	3.750	6.750
	3	1-3/4	8.500	4.243	0.813	1.000	0.688	9.875	11.250	2.563	3.750	7.000

Side Tap

Style F
(NFPA MS4)

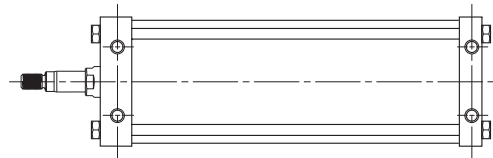
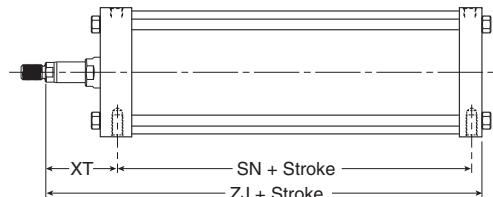
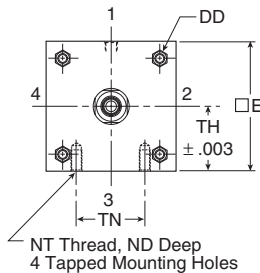
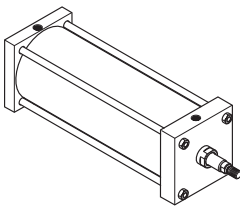

Style F Dimensions

Bore size	Rod no.	Rod dia. MM	E	ND	NT	+/- .003 TH	TN	XT	Add stroke	
									SN	ZJ
6	1	1-3/8	6.500	1.125	3/4-10	3.243	3.250	2.813	3.125	6.625
	3	1-3/4	6.500	1.125	3/4-10	3.243	3.250	3.063	3.125	6.875
8	1	1-3/8	8.500	1.125	3/4-10	4.243	4.500	2.813	3.250	6.750
	3	1-3/4	8.500	1.125	3/4-10	4.243	4.500	3.063	3.250	7.000



For inventory, lead times, and kit lookup, visit www.pdnplu.com

Cap Fixed Clevis

Style BB
 (NFPA MP1)

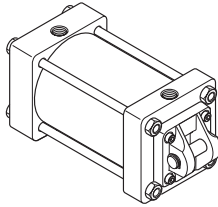

Note: For maximum swivel angle of BB mount with rear mounting plate, please reference cylinder accessories on page B80.

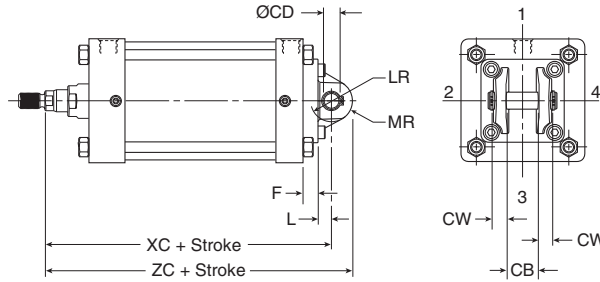

Cap Detachable Clevis

Style BC
 (NFPA MP2)

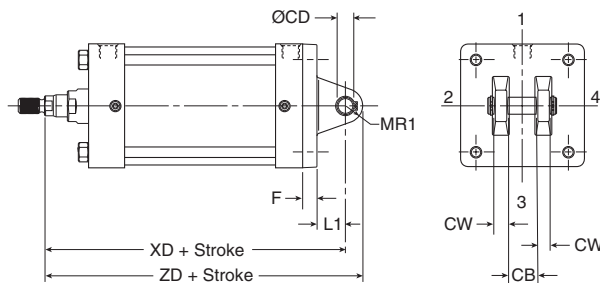
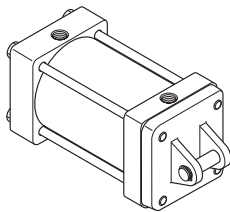

Styles BB and BC Dimensions

Bore size	Rod no.	Rod dia. MM	CB	Rod dia. +.000 -0.002 CD	CW	E	F	L	LR	L1	MR	MR1	Add stroke			
													XC	XD	ZC	ZD
6	1	1-3/8	1.500	1.001	0.750	6.500	0.750	0.750	1.250	1.500	1.125	1.000	8.125	8.875	9.250	9.875
	3	1-3/4	1.500	1.001	0.750	6.500	0.750	0.750	1.250	1.500	1.125	1.000	8.375	9.125	9.500	10.125
8	1	1-3/8	1.500	1.001	0.750	8.500	0.750	0.750	1.250	1.500	1.125	1.000	8.250	9.000	9.375	10.000
	3	1-3/4	1.500	1.001	0.750	8.500	0.750	0.750	1.250	1.500	1.125	1.000	8.500	9.250	9.625	10.250

Cap Detachable Eye

Style BE
 (NFPA MP4)
 (only 6" Bore)

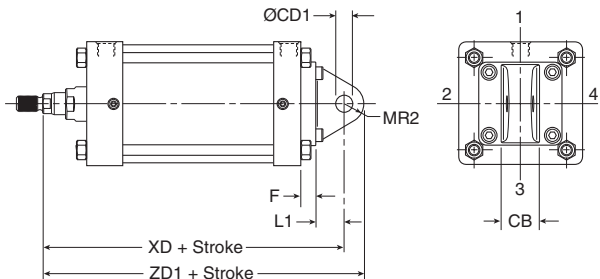
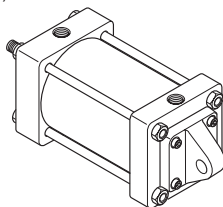

Style BE Dimensions

Bore size	Rod no.	Rod dia. MM	CB	Rod dia. +.002 +.004 CD1	E	F	L1	MR2	Add stroke	
									XD	ZD1
6	1	1-3/8	1.500	1.000	6.500	0.750	1.500	1.125	8.875	10.000
	3	1-3/4	1.500	1.000	6.500	0.750	1.500	1.125	9.125	10.250

B	Tie Rod Pneumatic Cylinders
	4MA Series
4MAJ Series	
2MNR Series	
ACVB Option	
LPSO Option	
P1D Series	



For inventory, lead time, and kit lookup, visit www.pdnplu.com

Head Trunnion

Style D
 (NFPA MT1)

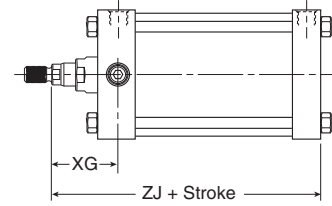
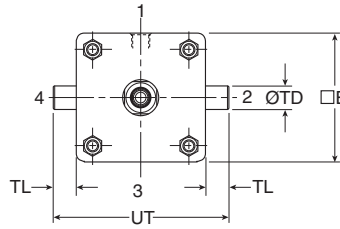
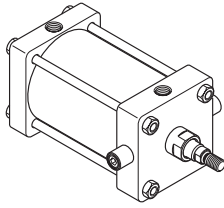

Cap Trunnion

Style DB
 (NFPA MT2)

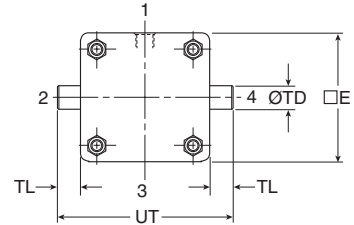
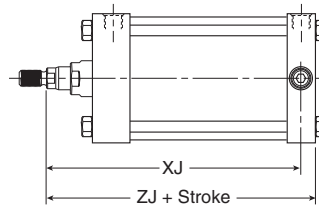
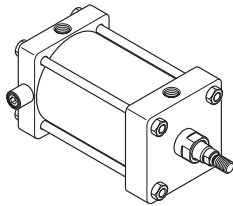

Intermediate Trunnion

Style DD
 (NFPA MT4)

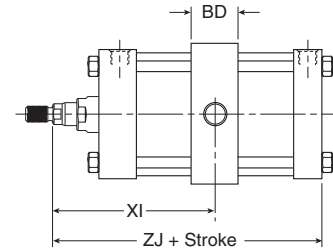
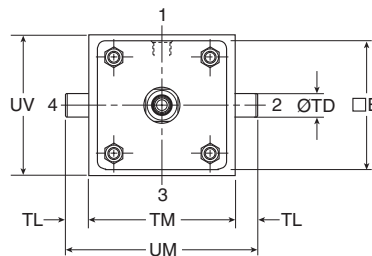
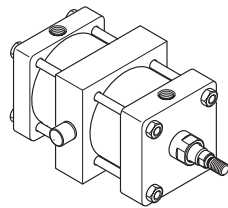

Styles D, DB and DD Dimensions

Bore size	Rod no.	Rod dia. MM	E	BD	Rod dia. +.000 -.001 TD	TL	TM	UM	UT	UV	XG	Min. XI	Add stroke	
													XJ	ZJ
6	1	1-3/8	6.500	2.500	1.375	1.375	7.625	10.375	9.250	7.000	2.625	4.813	5.875	6.625
	3	1-3/4	6.500	2.500	1.375	1.375	7.625	10.375	9.250	7.000	2.875	5.063	6.125	6.875
8	1	1-3/8	8.500	2.500	1.375	1.375	9.750	12.500	11.250	9.500	2.625	4.750	6.000	6.750
	3	1-3/4	8.500	2.500	1.375	1.375	9.750	12.500	11.250	9.500	2.875	5.000	6.250	7.000

B
 Tie Rod Pneumatic Cylinders
 4MA Series
 4MAJ Series
 2MNR Series
 ACVB Option
 LPSO Option
 P1D Series



For inventory, lead times, and kit lookup, visit www.pdnplu.com

Head Square

Style JB
 (NFPA ME3)

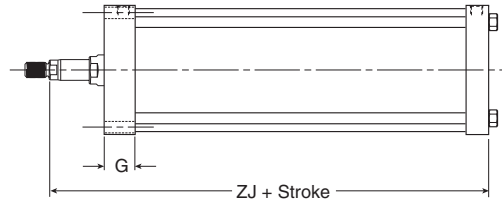
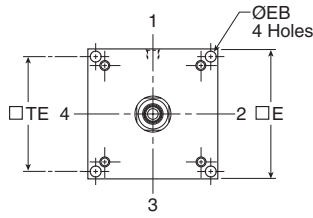
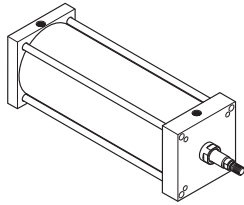

Cap Square

Style HB
 (NFPA ME4)

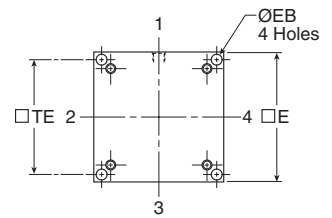
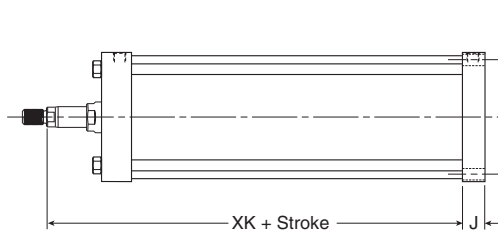
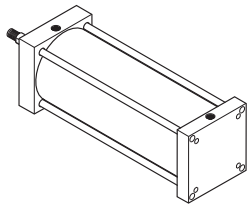

Styles JB and HB Dimensions

Bore size	Rod no.	Rod dia. MM	E	EB	G	J	TE	Add stroke	
								XK	ZJ
8	1	1-3/8	8.500	0.688	1.810	1.440	7.570	5.313	6.750
	3	1-3/4	8.500	0.688	1.810	1.440	7.570	5.563	7.000

B	Tie Rod Pneumatic Cylinders
	4MA Series
	4MAJ Series
	2MNR Series
ACVB Option	
LPSO Option	
P1D Series	

Mounting Kits and Accessories

Bore size	J (MF1)	H (MF2)	BB (MP1)	BC (MP2)	BE (MP4)	CB (MS1)	G (MS7)	Kit fastener torque units	
	Head rectangular flange	Cap rectangular flange	Cap fixed clevis	Cap detachable clevis	Cap detachable eye	Side end angles	Side end lug	inch-lbs	N-m
	Kit number	Kit number	Kit number	Kit number	Kit number	Kit number	Kit number		
1-1/2	L079700150	L079700150	L079710150	L079730150	L079720150	L079740150	L079750150	32-36	3.6-4.1
2	L079700200	L079700200	L079710200	L079730200	L079720200	L079740200	L079750200	72-82	8-9
2-1/2	L079700250	L079700250	L079710250	L079730250	L079720250	L079740250	L079750250	72-82	8-9
3-1/4	L079700325	L079700325	L079710325	L079730325	L079720325	L079740325	L079750325	216-228	24-25.3
4	L079700400	L079700400	L079710400	L079730400	L079720400	L079740400	L079750400	216-228	24-25.3
5	L079700500	L079700500	L079710500	L079730500	N/A	L079740500	N/A	360-372	41-42

** Spacer plate not used for 4" bore or double rod cylinders

Female Rod Clevis

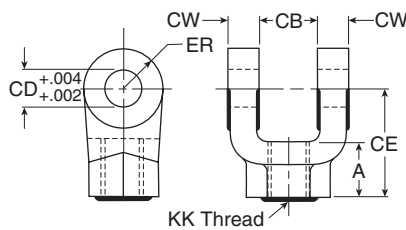

Symbol	1458030044	1458030050	1458030075	1458030088	1458030100	1458030125	1458030150
A	3/4	3/4	1-1/8	1-5/8	1-5/8	2	2-1/4
CB	3/4	3/4	1-1/4	1-1/2	1-1/2	2	2-1/2
CD	1/2	1/2	3/4	1	1	1-3/8	1-3/4
C E	1-1/2	1-1/2	2-1/8	2-15/16	2-15/16	3-3/4	4-1/2
CW	1/2	1/2	5/8	3/4	3/4	1	1-1/4
ER	1/2	1/2	3/4	1	1	1-3/8	1-3/4
KK	7/16-20	1/2-20	3/4-16	7/8-14	1-14	1-1/4-12	1-1/2-12
Load capacity (lbs)	4250	4900	11200	18800	19500	33500	45600

Rod Eye Knuckle

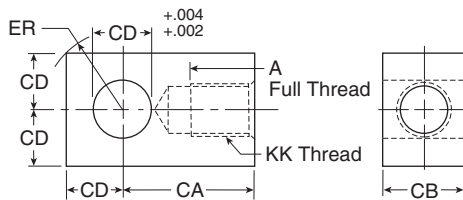

Symbol	1458040044	1458040050	1458040075	1458040088	1458040100	1458040125	1458040150
A	3/4	3/4	1-1/8	1-1/8	1-5/8	2	2-1/4
CA	1-1/2	1-1/2	2-1/16	2-3/8	2-13/16	3-7/16	4
CB	3/4	3/4	1-1/4	1-1/2	1-1/2	2	2-1/2
CD	1/2	1/2	3/4	1	1	1-3/8	1-3/4
ER	23/32	23/32	1-1/16	1-7/16	1-7/16	1-31/32	2-1/2
KK	7/16-20	1/2-20	3/4-16	7/8-14	1-14	1-1/4-12	1-1/2-12
Load capacity (lbs)	5000	5700	12100	13000	21700	33500	45000

Clevis Bracket

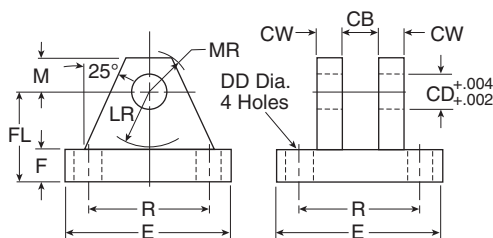

Symbol	1458050044	1458050050	1458050075	1458050100	1458050138	1458050175
CB	15/32	3/4	1-1/4	1-1/2	2	2-1/2
CD	7/16	1/2	3/4	1	1-3/8	1-3/4
CW	3/8	1/2	5/8	3/4	1	1-1/4
DD	17/64	13/32	17/32	21/32	21/32	29/32
E	2-1/4	3-1/2	5	6-1/2	7-1/2	9-1/2
F	3/8	1/2	5/8	3/4	7/8	7/8
FL	1	1-1/2	1-7/8	2-1/4	3	3-5/8
LR	5/8	3/4	1-3/16	1-1/2	2	2-3/4
M	3/8	1/2	3/4	1	1-3/8	1-3/4
MR	1/2	5/8	29/32	1-1/4	1-21/32	2-7/32
R	1.75	2.55	3.82	4.95	5.73	7.50
Load capacity (lbs)	3600	7300	14000	19200	36900	34000



For inventory, lead times, and kit lookup, visit www.pdnplu.com

B
 Tie Rod Pneumatic Cylinders
 4MA Series
 4MAJ Series
 2MNR Series
 ACVB Option
 LPSO Option
 P1D Series

Mounting Plate & Eye Bracket

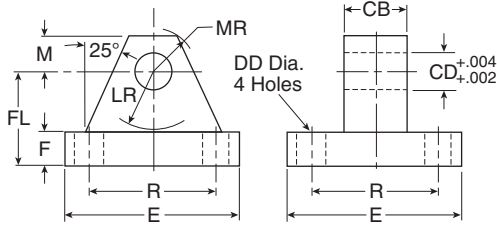

Symbol	1458060031	1458060050	1458060075	1458060100	1458060138	1458060175
CB	15/16	3/4	1-1/4	1-1/2	2	2-1/2
CD	15/16	1/2	3/4	1	1-3/8	1-3/4
DD	17/64	13/32	17/32	21/32	21/32	29/32
E	2-1/4	2-1/2	3-1/2	4-1/2	5	6-1/2
F	3/8	3/8	5/8	7/8	7/8	1-1/8
FL	1	1-1/8	1 7/8	2-3/8	3	3-3/8
LR	5/8	3/4	1-1/4	1-1/2	2-1/8	2-1/4
M	3/8	1/2	3/4	1	1-3/8	1-3/4
MR	1/2	9/16	7/8	1-1/4	1-5/8	2-1/8
R	1.75	1.63	2.55	3.25	3.82	4.95
Load Capacity (lbs)	1700	4100	10500	20400	21200	49480

1-1/2" to 8" Bore Cylinder Accessories

Rod end accessories can be selected by cylinder rod end thread size from Tables A & B below. Mating parts for rod end accessories are listed just to the right of the knuckle or clevis selected. Mounting plates for style MP1 & MP4 cylinder mounts are selected by bore size from Table C.

Table A				Table B			Table C		
Rod end thread size	Mating parts			Mating parts			Mounting plates		
	Female rod clevis	Eye bracket	Pivot pin	Knuckle	Clevis bracket	Pivot pin	Bore size	For mtg. style MP1 cylinder	For mtg. style MP4 cylinder
7/16-20	1458030044	1458060050	0856640050	1458040044	1458050050	0856640050	1-1/2	1458060050	1458050050
1/2-20	1458030050	1458060050	0856640050	1458040050	1458050050	0856640050	2	1458060050	1458050050
3/4-16	1458030075	1458060075	0856640075	1458040075	1458050075	0856640075	2-1/2	1458060050	1458050050
7/8-14	1458030088	1458060100	0856640100	1458040088	1458050100	0856640100	3-1/4	1458060075	1458050075
1-14	1458030100	1458060100	0856640100	1458040100	1458050100	0856640100	4	1458060075	1458050075
1-1/4-12	1458030125	1458060138	0856640138	1458040125	1458050138	0856640138	5	1458060075	—
1-1/2-12	1458030150	1458060175	0856640175	1458040150	1458050175	0856640175	6	1458060100	—
							8	1458060100	—

Pivot Pin

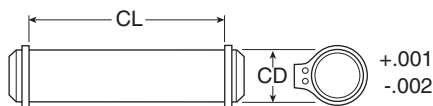

Symbol	0856640044	0856640050	0856640075	0856640100	0856640138	0856640175
CD	7/16	1/2	3/4	1	1-3/8	1-3/4
CL	1-5/16	1-7/8	2-5/8	3-1/8	4-1/8	5-3/16
Shear cap. (lbs)	6600	8600	19300	34300	65000	105200

Note: Pivot Pin must be ordered separately for single lug pivot mounting.

Maximum pivot angle for rear clevis mounts (BB mounts) and accessories

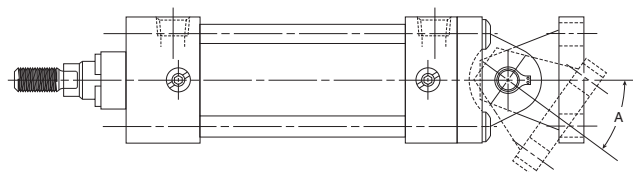

Bore	1-1/2	2	2-1/2	3-1/4	4	5	6	8
Angle A	52	43	29	50	49	45	42	42



For inventory, lead time, and kit lookup, visit www.pdnplu.com

Service Kits

Bore size	Rod dia.	Rod no.	RG - Rod gland cartridge kit. Includes gland and wiper, rod, and o-ring seals		Gland to head torque units		PK - Piston seal kit, standard lipseals. Includes piston and o-ring seals		SK - complete cylinder kit. Includes rod gland kit, piston seal kit, and cushion kits		Torque units endcap fastener or tie rod	
			Nitrile seal kit number	Fluorocarbon seals kit number	ft-lbs	Nm	Nitrile seal kit number	Fluorocarbon seal kit number	Nitrile seal kit number	Fluorocarbon seal kit number	inch-lbs	Nm
1-1/2	5/8	1	RG04MA0061	RG04MA0065	40-45	54-61	PK1504MA01	PK1504MA05	SK15104MA1	SK15104MA5	32-36	3.6-4.1
	1	2	RG04MA0101	RG04MA0105	45-50	61-68			SK15304MA1	SK15304MA5		
2	5/8	1	RG04MA0061	RG04MA0065	40-45	54-61	PK2004MA01	PK2004MA05	SK20104MA1	SK20104MA5	72-82	8-9
	1	3	RG04MA0101	RG04MA0105	45-50	61-68			SK20304MA1	SK20304MA5		
2-1/2	5/8	1	RG04MA0061	RG04MA0065	40-45	54-61	PK2504MA01	PK2504MA05	SK25104MA1	SK25104MA5	72-82	8-9
	1	3	RG04MA0101	RG04MA0105	45-50	61-68			SK25304MA1	SK25304MA5		
3-1/4	1	1	RG04MA0101	RG04MA0105	45-50	61-68	PK3254MA01	PK3254MA05	SK32104MA1	SK32104MA5	216-228	24-25.3
	1-3/8	3	RG04MA0131	RG04MA0135	75-80	102-108			SK32304MA1	SK32304MA5		
4	1	1	RG04MA0101	RG04MA0105	45-50	61-68	PK4004MA01	PK4004MA05	SK40104MA1	SK40104MA5	216-228	24-25.3
	1-3/8	3	RG04MA0131	RG04MA0135	75-80	102-108			SK40304MA1	SK40304MA5		
5	1	1	RG04MA0101	RG04MA0105	45-50	61-68	PK5004MA01	PK5004MA05	SK50104MA1	SK50104MA5	360-372	41-42
	1-3/8	3	RG04MA0131	RG04MA0135	75-80	102-108			SK50304MA1	SK50304MA5		
6	1-3/8	1	RG04MA0131	RG04MA0135	75-80	102-108	PK6004MA01	PK6004MA05	SK60104MA1	SK60104MA5	420-432	48-49
	1-3/4	3	RG04MA0171	RG04MA0175	90-95	122-129			SK60304MA1	SK60304MA5		
8	1-3/8	1	RG04MA0131	RG04MA0135	75-80	102-108	PK8004MA01	PK8004MA05	SK80104MA1	SK80104MA5	960-972	109-115
	1-3/4	3	RG04MA0171	RG04MA0175	90-95	122-129			SK80304MA1	SK80304MA5		

B
Tie Rod Pneumatic Cylinders

4MA Series

4MAJ Series

2MNR Series

ACVB Option

LPSO Option

P1D Series



For inventory, lead times, and kit lookup, visit www.pdnplu.com

4MAJ Series – Rod Lock

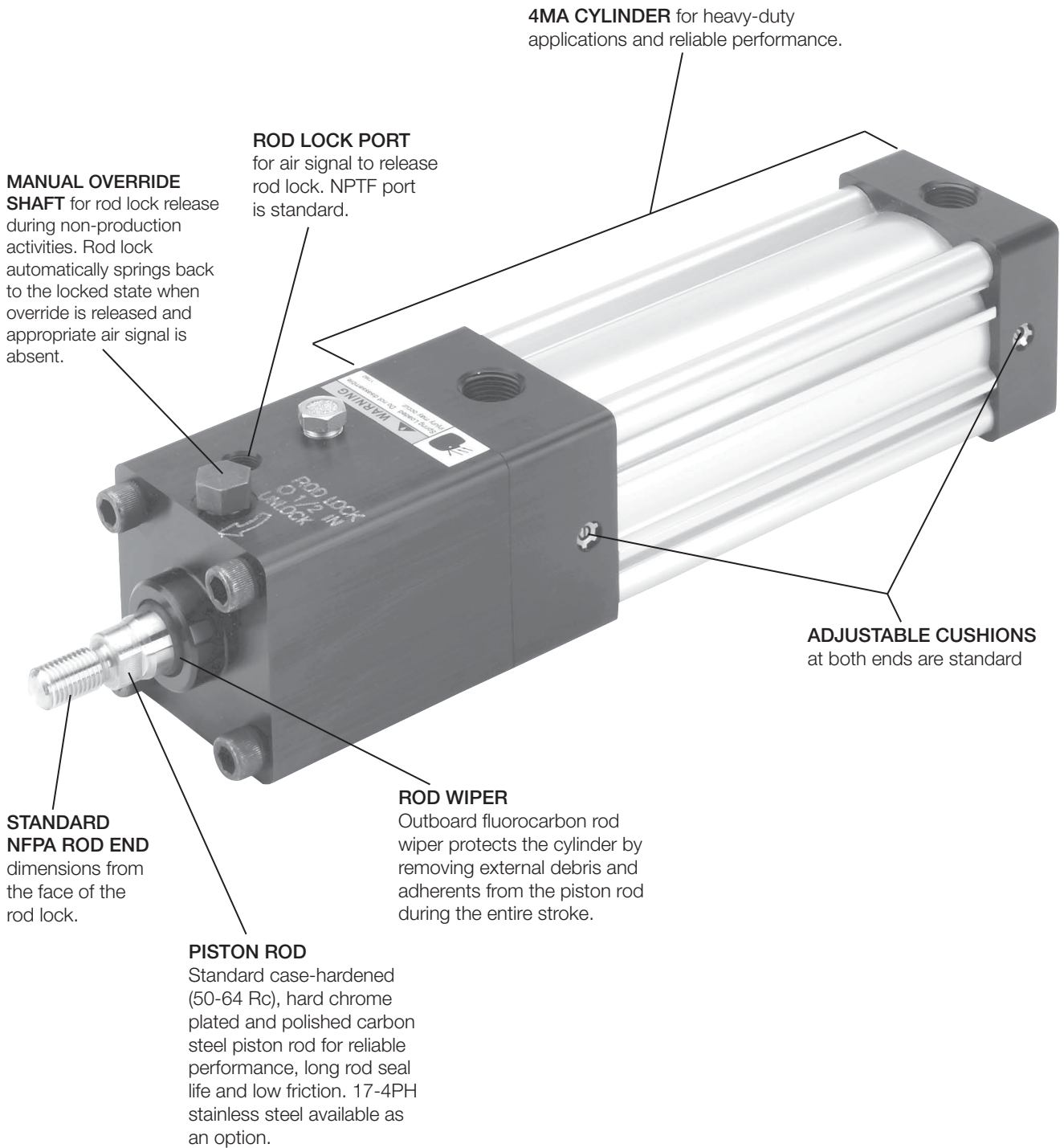

MANUAL OVERRIDE SHAFT for rod lock release during non-production activities. Rod lock automatically springs back to the locked state when override is released and appropriate air signal is absent.

ROD LOCK PORT for air signal to release rod lock. NPTF port is standard.

4MA CYLINDER for heavy-duty applications and reliable performance.

ADJUSTABLE CUSHIONS at both ends are standard

STANDARD NFPA ROD END dimensions from the face of the rod lock.

ROD WIPER
 Outboard fluorocarbon rod wiper protects the cylinder by removing external debris and adherents from the piston rod during the entire stroke.

PISTON ROD
 Standard case-hardened (50-64 Rc), hard chrome plated and polished carbon steel piston rod for reliable performance, long rod seal life and low friction. 17-4PH stainless steel available as an option.

B	Tie Rod Pneumatic Cylinders
	4MA Series
4MAJ Series	
2MNR Series	
ACVB Option	
LPSO Option	
P1D Series	

Rod Lock Features and Specifications

NFPA Non-Lube Pneumatic Cylinder with Manual Override Rod Lock

Rod lock version 4MA Series (the 4MAJ) provides precise load holding with virtually zero backlash and features high accuracy for demanding applications. The rod lock is a spring-activated type with air pressure release and clamps the piston rod to lock it into position. In the absence of an appropriate air signal, full holding force is applied to the piston rod. When a 60 PSI (or greater) air signal is present, the locking device is released. All rod locks include a manual override shaft to free the rod lock without air pressure during non-production activities.

Some key benefits of the 4MAJ Series Cylinders

Bolt-On Modularity – As a true cylinder accessory, the rod lock may be removed without affecting the base cylinder (1-1/2" to 5" bores). The same, great cylinder remains intact, allowing the rod lock to bolt-on with minimal length change. This modularity can be extremely important for special installations or while servicing the cylinder. Rod locks for 6" - 8" bores and all Style DD mounts (NFPA MT4) are fastened to the base cylinder using the base cylinder's tie rods. See drawings below.

Aesthetics – we have designed our rod locks with the same anodized aluminum extrusion used for the cylinder endcaps, resulting in a virtually seamless assembly. In addition, we focused every effort to create the shortest overall package, minimizing the need for customers to accommodate significantly longer cylinder lengths.

Functionality – With a holding force corresponding to 100 PSI on the cap end for nearly every bore size, the rod lock can be used for a variety of holding applications. The manual override shaft allows occasional release of the piston rod and automatically returns the rod lock back to the locked state when it is released and the appropriate air signal is absent. The front pilot diameter meets NFPA specifications and facilitates proper installation of the cylinder to customer equipment or cylinder accessories.

Ease of Order Entry – To order 4MA Series with the rod lock option, just change the product series to 4MAJ (the "J" is required for the rod lock option). See model code on page B40 for additional information.

1-1/2" to 5" Bores

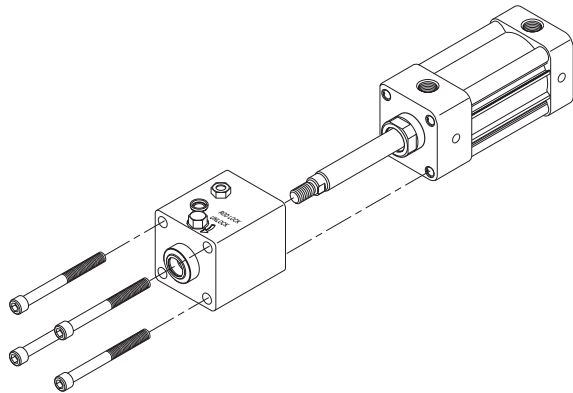

6" to 8" Bores and all style DD mounts (NFPA MT4)

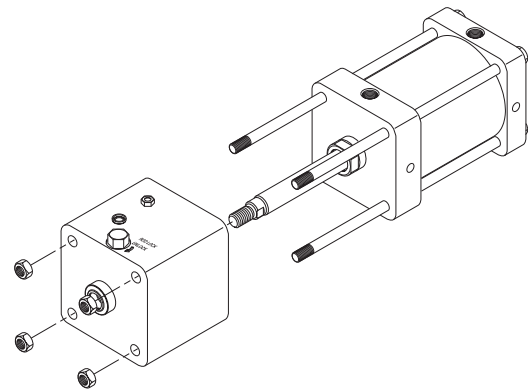

B	Tie Rod Pneumatic Cylinders	4MA Series
		4MAJ Series
		2MNR Series
		ACVB Option
		LPSO Option
		P1D Series

NFPA Non-Lube Pneumatic Cylinder with Manual Override Rod Lock

Connection

The signal air for the locking device can be obtained directly from a main air supply, or from the air supply serving the valve that controls the cylinder itself. For controlled ON/OFF operation of the locking device, a separate quick-venting valve is used.

The piston rod should not be moving when the locking device is activated. The locking device is not intended to brake a movement in repeated sequences.

NOTE: The 4MAJ is not intended for use in water service applications, or in environments that have high humidity levels and/or splashing fluids present.

NOTE: Exhaust air from the rod lock can be piped away when there are demands for a contaminant-free environment.

Operation at pressures lower than 60 PSI may lead to inadvertent engagement of the rod lock device.

Other Cylinder and Rod Lock Features:

- The 4MAJ rod lock will operate in both directions, engaging with the same holding force.
- The 4MAJ can be mounted in any position.
- Piston rod rotation is not allowed when the rod lock is engaged (not intended for torsional braking).
- Rod lock is suitable for infrequent dynamic braking (emergency stops). Since the 4MAJ rod lock is designed for static applications, repeated dynamic stops will cause rod and/or bearing wear and reduce holding forces.
- The rated holding force corresponds to static load conditions. If the rated value is exceeded, slipping and other problems may occur.
- If personal safety is required, an unrelated, redundant safety system is recommended.

Sample Pneumatic Circuit

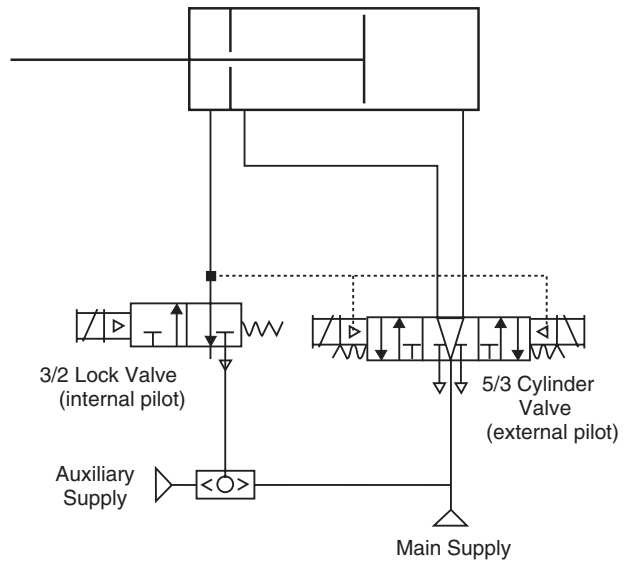

1. Lock valve must be maintained energized during cylinder motion, otherwise rod lock is engaged and cylinder valve shifts to mid position.
2. Cylinder valve must be maintained energized during extend or retract. Also keep energized at end of stroke until change of direction is desired.
3. Mid position of 5/3 Cylinder valve may be pressurized outlets if the combination of pressure load on the cylinder and inertia effects of the attached load do not exceed the holding force rating of the rod lock device, including allowance for wear.
4. Do not use cylinder lines for any logic functions – pressure levels vary too much.

Basic Rod Lock Specifications

Bore size	Rod no.	Rod dia. MM	Air chamber volume (in ³)	Engagement time (seconds)	Rated holding force (lbs)	Minimum torque to override (ft-lbs to hex shaft)
1-1/2	1	5/8	0.25	0.030	180	2
2	1	5/8	0.71	0.040	314	5
	3	1	0.68	0.040	250	5
2-1/2	1	5/8	1.26	0.045	491	7
	3	1	1.49	0.050	491	7
3-1/4	1	1	3.20	0.070	830	17
	3	1-3/8	2.11	0.060	830	17
4	1	1	6.73	0.100	1,256	45
	3	1-3/8	4.78	0.100	1,256	45
5	1	1	11.50	0.150	1,963	72
	3	1-3/8	9.50	0.130	1,963	72
6	1	1-3/8	14.08	0.175	2,830	135
	3	1-3/4	12.75	0.165	2,830	135
8	1	1-3/8	22.66	0.265	5,026	160
	3	1-3/4	23.21	0.265	5,026	160

Note: This specification data applies only to the rod lock part of the 4MAJ cylinder.

For cylinder volume and performance, please use cylinder dimensions and application criteria.



For inventory, lead time, and kit lookup, visit www.pdnplu.com

Tie Rod Pneumatic Cylinders 4MAJ Series, Rod Lock Option

Features

- Industry leading NFPA interchangeable rod lock cylinder with flexible construction
- Rod lock holding force equivalent to cylinder output force at 100 PSIG
- Bore sizes – 1-1/2", 2", 2-1/2", 3-1/4", 4", 5", 6" and 8"
- 17 standard styles mounting styles available
- Available in any practical stroke length
- Rod diameters – 5/8", 1", 1-3/8" and 1-3/4"
- Single rod end or double rod ends
- Adjustable cushions are standard at both ends
- Manual override feature standard on all configurations



Operating information

Operating pressure: 100 PSIG (7 bar) maximum air pressure, except 2" bore with 1" rod rated at 80 PSIG)
60 PSIG (4.1 bar) minimum air pressure to release rod lock

Temperature range –
Standard seals -10°F to 165°F (-23°C to 74°C)
Fluorocarbon seals -10°F to 250°F (-23°C to 121°C)

Filtration requirements: 40 micron, dry filtered air

Ordering information

2.00	C	J	4MAJ	U	1	4	A	C	6.000																																		
Bore size 1.50 ¹ 2.00 2.50 3.25 4.00 5.00 6.00 ¹¹ 8.00 ¹¹	Double Rod Cylinder ¹² Specify "K" only if double rod cylinder is required.	Mounting style Specify mounting style code (see table on following page).	Series 4MAJ 4MA rod lock cylinder	Ports ⁴ U NPTF R BSPP B BSPT T SAE	Piston rod number Specify rod code number for required diameter. ⁶	Special modification Specify "S" only for special modification other than rod end, and then describe modification in item notes. (Includes 4MAJ with Linear Position Sensor Option) ⁷	Piston rod thread type A Standard (UNF unified thread) W BSF British fine M* Metric	Cushion cap end C Cushioned cap end "C" is required	Stroke length Specify stroke length required in inches. ⁸																																		
Cushion head end C Cushioned head end "C" is required	Cylinder construction		Seals		Piston rod thread style		Rod material and gland code																																				
	<table border="1"> <tr><td>Blank*</td><td>Standard (extruded body, standard round lobe orientation)</td></tr> <tr><td>A*</td><td>Extruded body, round lobe orientation rotated 90 degrees from standard</td></tr> <tr><td>N*</td><td>Extruded body, round lobe orientation rotated 180 degrees from standard</td></tr> <tr><td>Z*</td><td>Extruded body, round lobe orientation rotated 270 degrees from standard</td></tr> <tr><td>T</td><td>Aluminum round tube and carbon steel tie rods & nuts</td></tr> </table>		Blank*	Standard (extruded body, standard round lobe orientation)	A*	Extruded body, round lobe orientation rotated 90 degrees from standard	N*	Extruded body, round lobe orientation rotated 180 degrees from standard	Z*	Extruded body, round lobe orientation rotated 270 degrees from standard	T	Aluminum round tube and carbon steel tie rods & nuts	<table border="1"> <tr><td>Blank</td><td>Standard (nitrile seals)</td></tr> <tr><td>V</td><td>Fluorocarbon seals⁵</td></tr> <tr><td>E</td><td>Fluorocarbon rod wiper and rod seal only⁶</td></tr> </table>		Blank	Standard (nitrile seals)	V	Fluorocarbon seals ⁵	E	Fluorocarbon rod wiper and rod seal only ⁶	<table border="1"> <tr><td>4</td><td>Small male</td></tr> <tr><td>8</td><td>Intermediate male</td></tr> <tr><td>9</td><td>Short female</td></tr> <tr><td>55</td><td>For use with split coupler⁹</td></tr> <tr><td>3</td><td>Special (and specify all dimensions required)</td></tr> </table>		4	Small male	8	Intermediate male	9	Short female	55	For use with split coupler ⁹	3	Special (and specify all dimensions required)	<table border="1"> <tr><td>Blank</td><td>Standard rod and gland</td></tr> <tr><td>H</td><td>Standard rod and HI LOAD gland</td></tr> <tr><td>Y</td><td>17-4 PH stainless steel rod and standard gland</td></tr> <tr><td>Z</td><td>17-4 PH stainless steel rod and HI LOAD gland</td></tr> </table>			Blank	Standard rod and gland	H	Standard rod and HI LOAD gland	Y	17-4 PH stainless steel rod and standard gland	Z	17-4 PH stainless steel rod and HI LOAD gland
Blank*	Standard (extruded body, standard round lobe orientation)																																										
A*	Extruded body, round lobe orientation rotated 90 degrees from standard																																										
N*	Extruded body, round lobe orientation rotated 180 degrees from standard																																										
Z*	Extruded body, round lobe orientation rotated 270 degrees from standard																																										
T	Aluminum round tube and carbon steel tie rods & nuts																																										
Blank	Standard (nitrile seals)																																										
V	Fluorocarbon seals ⁵																																										
E	Fluorocarbon rod wiper and rod seal only ⁶																																										
4	Small male																																										
8	Intermediate male																																										
9	Short female																																										
55	For use with split coupler ⁹																																										
3	Special (and specify all dimensions required)																																										
Blank	Standard rod and gland																																										
H	Standard rod and HI LOAD gland																																										
Y	17-4 PH stainless steel rod and standard gland																																										
Z	17-4 PH stainless steel rod and HI LOAD gland																																										
	Piston type ¹¹																																										
	<table border="1"> <tr><td>Blank</td><td>Lipseals and magnetic ring (legacy) (standard for 4ML)</td></tr> <tr><td>1</td><td>Lipseals, no magnetic ring (legacy)</td></tr> <tr><td>2</td><td>Lipseals, no magnetic ring (aluminum piston)</td></tr> <tr><td>3</td><td>Lipseals and magnetic ring (aluminum piston)</td></tr> <tr><td>4</td><td>Bumper seals, no magnetic ring</td></tr> <tr><td>6</td><td>Bumper seals and magnetic ring</td></tr> <tr><td>B</td><td>Lipseals, 1/4" thick bumpers both ends³</td></tr> <tr><td>H</td><td>Lipseals, 1/4" thick bumper head end³</td></tr> <tr><td>C</td><td>Lipseals, 1/4" thick bumper cap end³</td></tr> <tr><td>D</td><td>Lipseals and magnetic ring, 1/4" thick bumpers both ends³</td></tr> <tr><td>F</td><td>Lipseals and magnetic ring, 1/4" thick bumper head end³</td></tr> <tr><td>R</td><td>Lipseals and magnetic ring, 1/4" thick bumper cap end³</td></tr> </table>		Blank	Lipseals and magnetic ring (legacy) (standard for 4ML)	1	Lipseals, no magnetic ring (legacy)	2	Lipseals, no magnetic ring (aluminum piston)	3	Lipseals and magnetic ring (aluminum piston)	4	Bumper seals, no magnetic ring	6	Bumper seals and magnetic ring	B	Lipseals, 1/4" thick bumpers both ends ³	H	Lipseals, 1/4" thick bumper head end ³	C	Lipseals, 1/4" thick bumper cap end ³	D	Lipseals and magnetic ring, 1/4" thick bumpers both ends ³	F	Lipseals and magnetic ring, 1/4" thick bumper head end ³	R	Lipseals and magnetic ring, 1/4" thick bumper cap end ³																	
Blank	Lipseals and magnetic ring (legacy) (standard for 4ML)																																										
1	Lipseals, no magnetic ring (legacy)																																										
2	Lipseals, no magnetic ring (aluminum piston)																																										
3	Lipseals and magnetic ring (aluminum piston)																																										
4	Bumper seals, no magnetic ring																																										
6	Bumper seals and magnetic ring																																										
B	Lipseals, 1/4" thick bumpers both ends ³																																										
H	Lipseals, 1/4" thick bumper head end ³																																										
C	Lipseals, 1/4" thick bumper cap end ³																																										
D	Lipseals and magnetic ring, 1/4" thick bumpers both ends ³																																										
F	Lipseals and magnetic ring, 1/4" thick bumper head end ³																																										
R	Lipseals and magnetic ring, 1/4" thick bumper cap end ³																																										

* Please reference table on page B5. Only applies to 1-1/2" to 4" bore.

¹ Not available with 1" rod diameter (rod number 2) for 1-1/2" bore. Not available with Linear Position Sensor Option (LPSO).

³ Addition of 1/4" bumper results in a 1/4" stroke loss per bumper, per end. For example, a 6" stroke cylinder with 1/4" bumpers at both ends (option B) has an effective stroke of 5-1/2".

⁴ Port thread styles only for base cylinder. Rod lock port is always NPTF. If a different rod lock port thread style is required, place an "S" for special in the Special Modification field and indicate the desired rod lock port thread style in the item notes.

⁵ Fluorocarbon seals for 4MAJ are only for external chemical compatibility applications, not high temperature.

⁶ Used for external chemical compatibility applications, not high temperature.

⁷ For Linear Position Sensor Option (LPSO), please include the following information for the Special Modification item notes:
a. Sensor part number (please reference pages B72-B76)
b. Sensor position
c. Port position (if other than position 1)
d. Length of stop tubing, gross stroke and net stroke (if required)

⁸ Review Piston Rod Selection Chart, please reference page A14 to determine proper piston rod diameter.

⁹ For additional information regarding this style, please reference page B77. If non-standard Rod Material and Gland Code is required with this option, please place an "S" for special in Special Modification field and specify Rod Material and Gland Code in the item notes.

¹⁰ If a stop tube is required, specify gross stroke (net stroke + stop tube) in the model number, then place an "S" for special in the Special Modification field and specify the stop tube length in the item notes. Not available with Piston Types (blank) and 1 for 1-1/2" - 5" bore cylinders.

¹¹ 6"-8" bore 4MAJ can accept only Piston Types (blank) and 3. The (blank) piston for 6"-8" bores is aluminum, lipseals, no magnetic ring. Composite pistons not available with oversize rod number 3.

Cylinder dimensions will approximate dimensions for 4MAJ. Piston Type option (blank), 3, 6, D, F or R is required. Please consult the Pneumatic Division for additional information.

For ordering purposes, when special options or common modifications are requested, the factory will assign a sequential part number in place of the model number.



For inventory, lead times, and kit lookup, visit www.pdnplu.com

Mounting Styles

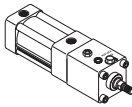
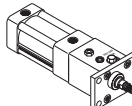
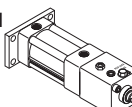
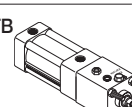
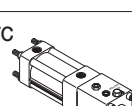
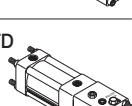
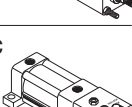
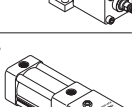
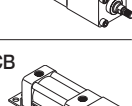
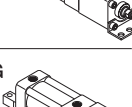
Mounting style	NFPA mounting	Description	4MAJ	Bore size
	MX0	No Mount	4MAJ	1-1/2 - 8
			w/LPSO	2 - 8
			w/LPSO w/stop tube	2 - 8
	MF1	Head Rectangular Flange	4MAJ	1-1/2 - 6
			w/LPSO	2 - 6 *
			w/LPSO w/stop tube	2 - 6
	MF2	Cap Rectangular Flange	4MAJ	1-1/2 - 6
			w/LPSO	2 - 6 *
			w/LPSO w/stop tube	2 - 6 *
	MX3	Tie Rods Extended Head End	4MAJ	1-1/2 - 8
			w/LPSO	2 - 6 *
	MX2	Tie Rods Extended Cap End	4MAJ	1-1/2 - 8
	MX1	Tie Rods Extended Both Ends	4MAJ	1-1/2 - 8
	MS2	Side Lug	4MAJ	1-1/2 - 8
			w/LPSO	2 - 8
			w/LPSO w/stop tube	2 - 8
	MS4	Side Tap	4MAJ	1-1/2 - 8
			w/LPSO	2 - 8
			w/LPSO w/stop tube	2 - 8
	MS1	Side End Angle	4MAJ	1-1/2 - 8
			w/LPSO	2 - 8
			w/LPSO w/stop tube	2 - 8
	MS7	Side End Lug	4MAJ	1-1/2 - 4
			w/LPSO	2 - 4
			w/LPSO w/stop tube	2 - 4

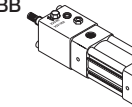
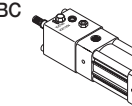
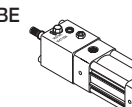
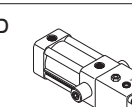
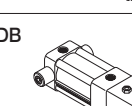
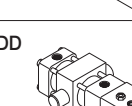
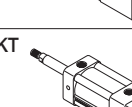
Mounting style	NFPA mounting	Description	4MAJ	Bore size
	MP1	Cap Fixed Clevis	4MAJ	1-1/2 - 8
			w/LPSO	2 - 8 *
			w/LPSO w/stop tube	2 - 8 *
	MP2	Cap Detachable Clevis	4MAJ	1-1/2 - 8
			w/LPSO	2 - 8 *
			w/LPSO w/stop tube	2 - 8 *
	MP4	Cap Detachable Eye	4MAJ	1-1/2 - 6
			w/LPSO	2 - 6 *
			w/LPSO w/stop tube	2 - 6 *
	MT1	Head Trunnion	4MAJ	1-1/2 - 8
			w/LPSO	2 - 8
			w/LPSO w/stop tube	2 - 8
	MT2	Cap Trunnion	4MAJ	1-1/2 - 8
			w/LPSO	2 - 8 *
			w/LPSO w/stop tube	2 - 8 *
	MT4	Intermediate Trunnion	4MAJ	1-1/2 - 8
	MDX0	Double Rod End, No Mount	4MAJ	1-1/2 - 8
			w/LPSO	2 - 8
			w/LPSO w/stop tube	2 - 8

* May interfere with mounting. Please provide clearance for Linear Sensor overhang (see page B73).

B

Tie Rod Pneumatic Cylinders

4MA Series

4MAJ Series

2MNR Series

ACVB Option

LPSO Option

P1D Series

Sensors

See section L for sensors.



For inventory, lead time, and kit lookup, visit www.pdnplu.com

General Specifications

- NFPA interchangeable*
- Bore sizes – 1-1/2", 2", 2-1/2", 3-1/4", 4", 5", 6" and 8"
- Strokes – available in any practical stroke length
- Rod diameters – 5/8", 1", 1-3/8" and 1-3/4"
- Rod end styles – 4 standard, specials available
- Single rod end or double rod ends
- Cushions – required and adjustable at both ends
- Operating pressure –
 100 PSIG (6.9 bar)** maximum air service, except for
 2" bore with 1" rod (rated at 80 PSIG)
 60 PSIG (4.1 bar) minimum air pressure to release
 rod lock

- Media – dry, filtered air
- Temperature range –
 -10°F to 165°F (-23°C to 74°C)
- Mounting styles – 18 standard styles

* NFPA standards do not specify rod lock cylinder dimensions. The 4MA cylinder and mounting accessories subscribe to NFPA standards.

** The pressure ratings are for these devices as stated. However, the rated holding forces of the rod locks are as stated on page B62.

For material options, including seals and piston rods, please see Material Specifications on below.

Cylinder Weights

Bore (inch)	Rod (inch)	No Mount Single Rod		No Mount Double Rod	
		Base wt. (lbs.)	Per inch (lbs.)	Base wt. (lbs.)	Per inch (lbs.)
1-1/2	0.625	4.23	0.20	4.66	0.28
	1.00	6.49	0.35	7.84	0.58
2	0.625	5.90	0.21	6.55	0.30
	1.00	6.49	0.35	7.84	0.58
2-1/2	0.625	7.75	0.23	8.46	0.31
	1.00	8.56	0.37	10.24	0.60
3-1/4	1.00	13.95	0.42	15.15	0.64
	1.375	15.93	0.62	19.46	1.05
4	1.00	20.80	0.49	22.32	0.71
	1.375	22.29	0.69	26.37	1.12
5	1.00	31.20	0.61	33.84	0.84
	1.375	32.72	0.81	36.89	1.24
6	1.375	55.50	0.87	60.63	1.30
	1.75	57.61	1.13	65.41	1.82
8	1.375	94.50	1.25	100.15	1.68
	1.75	96.63	1.51	104.90	2.20

Standard Cushion Position

Mounting Code	Position
All except D, DB, DD	2
D, DB, DD	3

Standard Cylinder Port Sizes

Bore	NPTF / BSPT	BSPP	SAE
1-1/2	3/8	G3/8	6
2	3/8	G3/8	6
2-1/2	3/8	G3/8	6
3-1/4	1/2	G1/2	10
4	1/2	G1/2	10
5	1/2	G1/2	10
6	3/4	G3/4	12
8	3/4	G3/4	12

Port thread styles for base cylinder only. Rod lock port is always NPTF. If a different rod lock port thread style is required, place an "S" for special in the Special Modification field and indicate the desired rod lock port thread style in the item notes. Standard rod lock port sizes are detailed in cylinder dimension tables.

Mounting Weight Adders

Bore (inch)	Weight (lbs) by mounting style							
	J, H	D, DB	BB	CB, G	DD	BE	C	BC
1-1/2	0.51	0.50	0.15	0.36	1.70	0.23	0.15	0.20
2	0.76	0.50	0.26	0.65	2.38	0.32	0.15	0.29
2-1/2	1.13	0.50	0.38	1.05	3.00	0.42	0.15	0.41
3-1/4	2.76	0.50	0.98	1.38	5.35	1.26	0.35	1.06
4	4.05	0.50	1.35	2.20	6.75	1.62	0.35	1.49
5	6.46	0.50	1.20	4.29	8.77	1.26	0.57	2.41
6	10.74	1.22	2.91	5.88	15.52	2.91	0.69	11.38
8	N/A	1.22	2.91	7.84	25.01	N/A	0.67	17.31

Standard Temperatures and Applications

Same as 4MA for 4MAJ, with the following additions/changes:

Piston rod (other materials not available)	Case-hardened, chrome plated carbon steel (standard) 17-4 PH stainless steel, chrome plated.
Rod lock housing	Black anodized aluminum alloy
Rod lock wiper	Fluorocarbon
Manual override shaft	416 stainless steel
Rod lock screws	Black oxidized steel alloy

P
 Tie Rod Pneumatic Cylinders
 4MA Series
 4MAJ Series
 2MNR Series
 ACVB Option
 LPSO Option
 P1D Series



For inventory, lead times, and kit lookup, visit www.pdnplu.com

How to Select a 4MAJ Cylinder

Parker cylinders are available based on air operating pressure. The many styles, sizes and optional features available assure that your application requirements are precisely met. To select a cylinder, follow these simple steps:

- Step 1 - **Determine the correct cylinder bore size** necessary to achieve required force using the available operating pressure.
- Step 2 - **Determine the series cylinder to use**, based on operating pressure.
- Step 3 - **Turn to the appropriate cylinder selection section.** Select the mounting style that fits your installation needs. Determine the bore and rod sizes available for the model you select. Then complete model selection.
 - Choose a rod end style and the desired rod end accessories.
 - Size the cylinder to meet your application requirements.
- Step 4 - **Consider the following conditions** which may require further modifications to the cylinder you have selected.

Application Condition	Check the Following
Quick Starts or Stops	Confirm that determined thrust is sufficient to accelerate or decelerate cylinder and load within prescribed distance. Mandatory cushions can be used to reduce shock during deceleration, check that peak pressures will be within tolerable limits.
Long Push Stroke	Check whether stop tube (4MAJ with aluminum piston only) is required to prevent excessive bearing loads and wear.
High-column Loading Long Push Stroke	Determine if standard size piston rod is strong enough to accommodate intended load. See Piston Rod Selection Chart or Application Engineering section for recommendations.
Long Horizontal Stroke	Determine if standard size piston rod is strong enough to accommodate intended load.

Options and Modifications:

- Piston Bumper Seals
- Piston Bumpers (1/4" Thick)
- Port and Cushion Adjust Relocation
- Port Thread Styles
- Multiple Ports
- Adjustable Sensors
- Linear Position Sensing Option (LPSO)
- Double Rod End
- Rod End Modifications
- Stop Tube
- Mixed Mountings
- Shock Absorber on Cap End
- Round Tube and Tie Rod Construction
- Air Cylinder/Valve Combination (ACVB)
- Hydro-Check for smooth hydraulic control

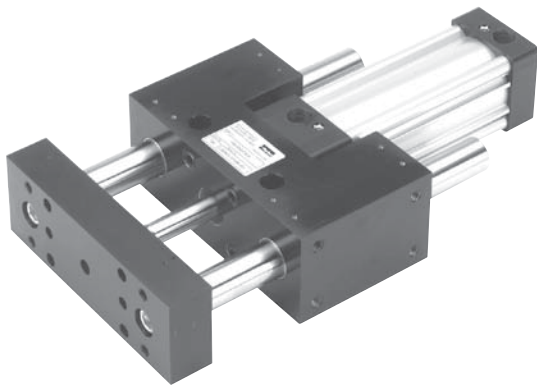

For a guided version of the 4MAJ Series, please see the HB Series in Section E.

B

Tie Rod Pneumatic
Cylinders

4MA
Series

4MAJ
Series

2MNR
Series

ACVB
Option

LPSO
Option

P1D
Series

Style T

Tie Rod Pneumatic Cylinders 4MAJ Series, Rod Lock Option

Single Rod

No Mount Basic

Style T
(NFPA MX0)

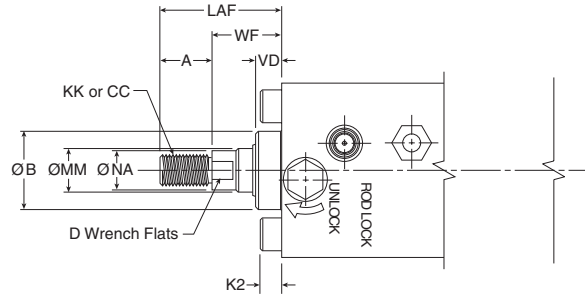
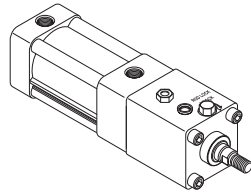

For dimensions of all standard rod end styles, see next page.

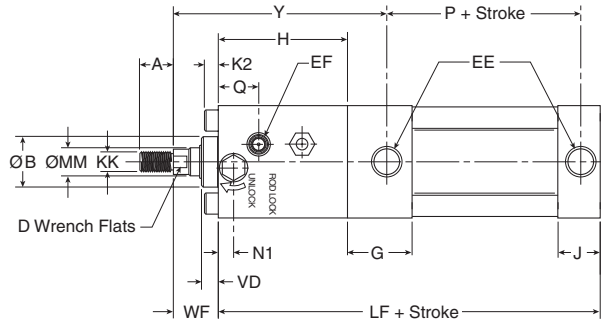
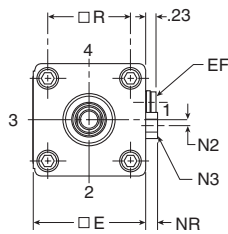

Style T Dimensions

Bore size	Rod no.	Rod dia. MM	Thread			A	AA	B	D	E	EE (NPTF)	EF (NPTF)	G	H	J
			Style 8 CC	Style 4 & 9 KK	Style 6										
1-1/2	1	5/8	1/2 - 20	7/16 - 20	5/8 - 18	0.750	2.020	1.124	1/2	2.000	3/8	1/8	1.438	2.625	0.938
	3	1	7/8 - 14	3/4 - 16	1 - 14	1.125	2.600	1.499	7/8	2.500	3/8	1/8	1.375	3.875	0.937
2	1	5/8	1/2 - 20	7/16 - 20	5/8 - 18	0.750	3.100	1.124	1/2	3.000	3/8	1/8	1.344	2.875	0.938
	3	1	7/8 - 14	3/4 - 16	1 - 14	1.125	3.100	1.499	7/8	3.000	3/8	1/8	1.344	4.000	0.938
2-1/2	1	5/8	1/2 - 20	7/16 - 20	5/8 - 18	0.750	3.900	1.499	7/8	3.750	1/2	1/4	1.594	4.500	1.125
	3	1-3/8	1-1/4 - 12	1 - 14	1-3/8 - 14	1.625	3.900	1.999	1-1/8	3.750	1/2	1/4	1.594	4.875	1.125
3-1/4	1	1	7/8 - 14	3/4 - 16	1 - 14	1.125	4.700	1.499	7/8	4.500	1/2	1/4	1.594	4.875	1.125
	3	1-3/8	1-1/4 - 12	1 - 14	1-3/8 - 14	1.625	4.700	1.999	1-1/8	4.500	1/2	1/4	1.594	5.125	1.125
4	1	1	7/8 - 14	3/4 - 16	1 - 14	1.125	5.800	1.499	7/8	5.500	1/2	1/4	1.594	5.375	1.219
	3	1-3/8	1-1/4 - 12	1 - 14	1-3/8 - 14	1.625	5.800	1.999	1-1/8	5.500	1/2	1/4	1.594	5.750	1.219
5	1	1	7/8 - 14	3/4 - 16	1 - 14	1.125	5.800	1.499	7/8	5.500	1/2	1/4	1.594	5.375	1.219
	3	1-3/8	1-1/4 - 12	1 - 14	1-3/8 - 14	1.625	5.800	1.999	1-1/8	5.500	1/2	1/4	1.594	5.750	1.219

Bore size	Rod no.	Rod dia. MM	K2	LAF	N1	N2	Hex N3	NA	NR	Q	R	VD	WF	Y	Add stroke	
															LF	P
1-1/2	1	5/8	0.250	1.750	0.220	0.140	5/16	0.563	0.190	0.715	1.430	0.375	1.000	4.500	6.250	2.313
	3	1	0.313	2.500	0.338	0.146	1/2	0.938	0.275	1.065	1.840	0.500	1.375	6.125	7.500	2.313
2	1	5/8	0.313	1.750	0.346	0.150	1/2	0.563	0.265	0.755	2.190	0.500	1.000	4.813	6.625	2.375
	3	1	0.313	2.500	0.346	0.148	1/2	0.938	0.265	1.120	2.190	0.500	1.375	6.313	7.750	2.375
2-1/2	1	5/8	0.313	1.750	0.346	0.150	1/2	0.563	0.265	0.755	2.190	0.500	1.000	4.813	6.625	2.375
	3	1	0.313	2.500	0.346	0.148	1/2	0.938	0.265	1.120	2.190	0.500	1.375	6.313	7.750	2.375
3-1/4	1	1	0.375	2.500	0.631	0.180	5/8	0.938	0.340	1.510	2.760	0.500	1.375	6.938	8.750	2.625
	3	1-3/8	0.375	3.250	0.813	0.247	5/8	1.313	0.350	1.645	2.760	0.625	1.625	7.563	9.125	2.625
4	1	1	0.375	2.500	0.625	0.240	7/8	0.938	0.500	1.725	3.320	0.500	1.375	7.313	9.125	2.625
	3	1-3/8	0.375	3.250	0.771	0.276	7/8	1.313	0.490	1.679	3.320	0.750	1.625	7.813	9.375	2.625
5	1	1	0.500	2.500	0.720	0.220	7/8	0.938	0.500	1.995	4.100	0.500	1.375	7.813	9.875	2.875
	3	1-3/8	0.500	3.250	0.720	0.220	7/8	1.313	0.490	2.330	4.100	0.750	1.625	8.438	10.250	2.875



For inventory, lead times, and kit lookup, visit www.pdnplu.com

Rod End Thread Styles

Tie Rod Pneumatic Cylinders 4MAJ Series, Rod Lock Option

Rod End

Thread Style 4
(NFPA Style SM)
Small Male

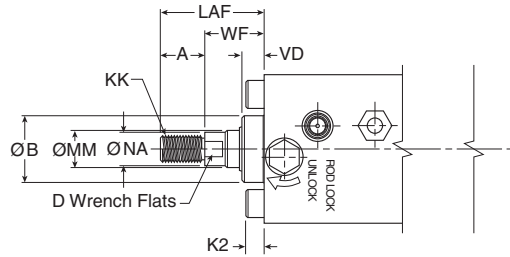

Thread Style 8
(NFPA Style IM)
Intermediate Male

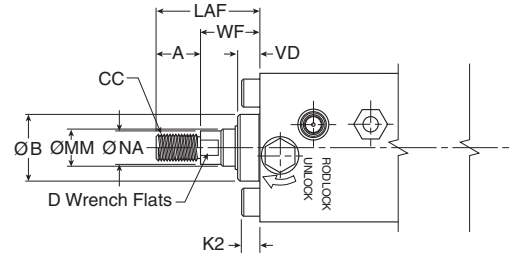

Thread Style 9
(NFPA Style SF)
Short Female

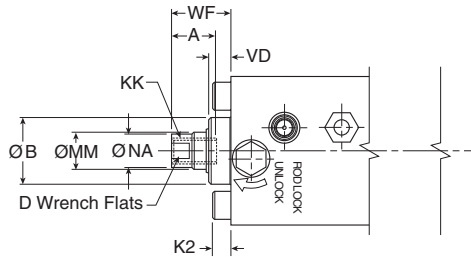

Thread Style 55
For use with Split Coupler
(please reference page B77 for more information)

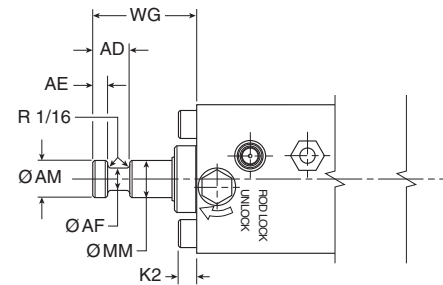

Thread Style 3 - "Special Thread"

Special threads, rod extensions, rod eyes, blanks, etc. are also available. To order, specify "Style 3" and give desired dimensions for KK or CC, A and W or WF. If otherwise special, please supply dimensioned sketch.

Rod End Dimensions

Bore size	Rod no.	Rod dia. MM	Thread		Style 6	A	AD	AE	AF	AM	Bore dia. +.000 / -.002	D	K2	LAF	NA	VD	WF	WG
			Style 8 CC	Style 4 & 9 KK														
1-1/2	1	5/8	1/2 - 20	7/16 - 20	5/8 - 18	0.750	0.625	0.250	0.375	0.570	1.124	1/2	0.250	1.750	0.563	0.375	1.000	1.750
	2	5/8	1/2 - 20	7/16 - 20	5/8 - 18	0.750	0.625	0.250	0.375	0.570	1.124	1/2	0.313	1.750	0.563	0.375	1.000	1.750
2	3	1	7/8 - 14	3/4 - 16	1 - 14	1.125	0.938	0.375	0.688	0.950	1.499	7/8	0.313	2.500	0.938	0.500	1.375	2.375
	1	5/8	1/2 - 20	7/16 - 20	5/8 - 18	0.750	0.625	0.250	0.375	0.570	1.124	1/2	0.313	1.750	0.563	0.500	1.000	1.750
2-1/2	3	1	7/8 - 14	3/4 - 16	1 - 14	1.125	0.938	0.375	0.688	0.950	1.499	7/8	0.313	2.500	0.938	0.500	1.375	2.375
	1	5/8	1/2 - 20	7/16 - 20	5/8 - 18	0.750	0.625	0.250	0.375	0.570	1.124	1/2	0.313	1.750	0.563	0.500	1.000	1.750
3-1/4	3	1	7/8 - 14	3/4 - 16	1 - 14	1.125	0.938	0.375	0.688	0.950	1.499	7/8	0.375	2.500	0.938	0.500	1.375	2.375
	3	1-3/8	1-1/4 - 12	1 - 14	1-3/8 - 14	1.625	1.063	0.375	0.875	1.320	1.999	1-1/8	0.375	3.250	1.313	0.625	1.625	2.750
4	1	1	7/8 - 14	3/4 - 16	1 - 14	1.125	0.938	0.375	0.688	0.950	1.499	7/8	0.375	2.500	0.938	0.500	1.375	2.375
	3	1-3/8	1-1/4 - 12	1 - 14	1-3/8 - 14	1.625	1.063	0.375	0.875	1.320	1.999	1-1/8	0.375	3.250	1.313	0.750	1.625	2.750
5	1	1	7/8 - 14	3/4 - 16	1 - 14	1.125	0.938	0.375	0.688	0.950	1.499	7/8	0.500	2.500	0.938	0.500	1.375	2.375
	3	1-3/8	1-1/4 - 12	1 - 14	1-3/8 - 14	1.625	1.063	0.375	0.875	1.320	1.999	1-1/8	0.500	3.250	1.313	0.750	1.625	2.750

B

Tie Rod Pneumatic Cylinders

4MA Series

4MAJ Series

2MNR Series

ACVB Option

LPSO Option

P1D Series



For inventory, lead time, and kit lookup, visit www.pdnplu.com

K-type Cylinder

To determine dimensions for a double rod end cylinder, first refer to the desired single rod end mounting style cylinder shown in this catalog section. After selecting the necessary dimensions from that drawing, return to this page and supplement the single rod end dimensions with those shown in the drawings and dimension table below. Note that double rod end cylinders have a head dimension G at both ends,

Tie Rod Pneumatic Cylinders 4MAJ Series – 1-1/2" to 5" Bore Size

and that LG replaces LF, P_k replaces P, etc. The double rod end dimensions differ from, or are in addition to, those for single rod cylinders.

When a double rod end cylinder has two different rod ends, please clearly state which rod end is to be available at which head end.

K-type 1-1/2" to 5" Bore Size

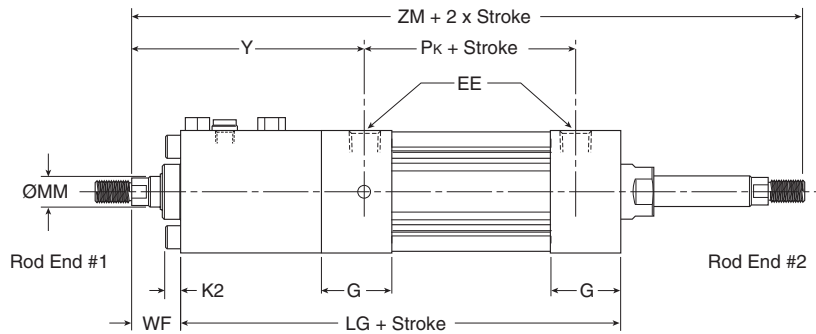
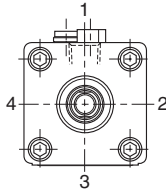
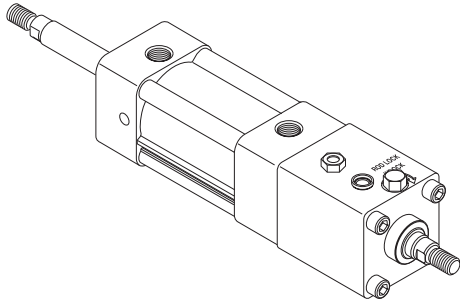

Double rod cylinders not available with composite piston type.

Mounting styles for single rod models	Corresponding mounting styles for double rod models
C	KC
CB	KCB
D	KD
DD	KDD
F	KF
G	KG
J	KJ
T	KT
TB	KTB
TD	KTD

Style KT Dimensions

Bore size	Rod no.	Rod dia. MM	EE (NPTF)	G	K2	WF	Y	Add Stroke								ZM
								LG	Pk	SAk	XAk	SSk	SNk	SEk	XEk	
1-1/2	1	5/8	3/8	1.438	0.250	1.000	4.500	6.750	2.375	8.750	8.750	3.375	2.250	9.000	8.875	8.750
	2	1	5/8	1.375	0.313	1.000	4.750	7.000	2.375	9.000	9.000	3.375	2.250	9.625	9.313	9.000
	3	1	3/8	1.375	0.313	1.375	6.125	8.000	2.375	10.000	10.375	3.375	2.250	10.625	10.688	10.750
2-1/2	1	5/8	3/8	1.344	0.313	1.000	4.813	7.125	2.375	9.125	9.125	3.500	2.375	10.000	9.563	9.125
	3	1	3/8	1.344	0.313	1.375	6.313	8.250	2.375	10.250	10.625	3.500	2.375	11.125	11.063	11.000
3-1/4	1	1	1/2	1.594	0.375	1.375	6.938	9.250	2.625	11.750	11.875	3.750	2.625	12.250	12.125	12.000
	3	1-3/8	1/2	1.594	0.375	1.625	7.563	9.625	2.625	12.125	12.500	3.750	2.625	12.625	12.750	12.875
4	1	1	1/2	1.594	0.375	1.375	7.313	9.625	2.625	12.125	12.250	3.750	2.625	12.875	12.625	12.375
	3	1-3/8	1/2	1.594	0.375	1.625	7.813	9.875	2.625	12.375	12.750	3.750	2.625	13.125	13.125	13.125
5	1	1	1/2	1.594	0.500	1.375	7.813	10.313	2.813	13.063	13.063	3.563	2.813	-	-	13.063
	3	1-3/8	1/2	1.594	0.500	1.625	8.438	10.688	2.813	13.438	13.688	3.563	2.813	-	-	13.938
Replaces Dimension								LF	P	SA	XA	SS	SN	SE	XE	-
On Single Rod Mounting Styles								All Styles	All Styles	CB	CB	C	F	G	G	All



For inventory, lead times, and kit lookup, visit www.pdnplu.com

Style J, H

**Tie Rod Pneumatic Cylinders
4MAJ Series – 1-1/2" to 5" Bore Size**

Head Rectangular Flange

Style J
(NFPA MF1)

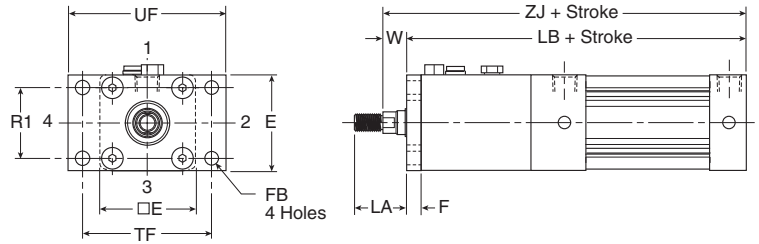
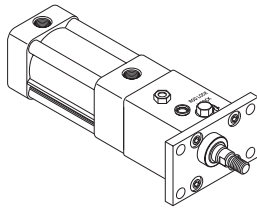

Note: Style J has a W dimension instead of WF and a LA dimension instead of LAF because of the flange installation. Please use dimensions W and LA regarding rod ends only for Style J. For reference, $WF = W + F$ and $LA = W + A$.

Cap Rectangular Flange

Style H
(NFPA MF2)

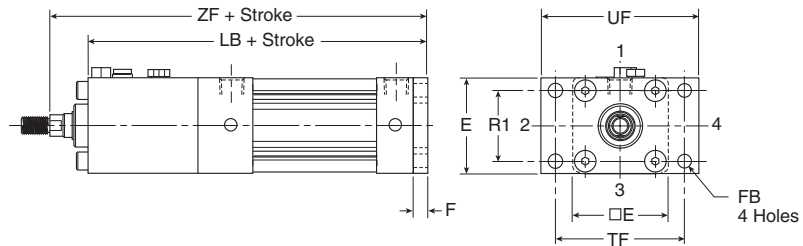
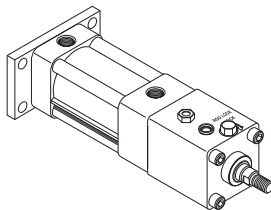

Styles J and H Dimensions

Bore size	Rod no.	Rod dia. MM	A	E	F	FB	LA	R1	TF	UF	W	Add stroke		
												LB	ZF	ZJ
1-1/2	1	5/8	0.750	2.000	0.375	0.313	1.375	1.430	2.750	3.375	0.625	6.625	7.625	7.250
	1	5/8	0.750	2.500	0.375	0.375	1.375	1.840	3.375	4.125	0.625	6.875	7.875	7.500
2	3	1	1.125	2.500	0.375	0.375	2.125	1.840	3.375	4.125	1.000	7.875	9.250	8.875
	1	5/8	0.750	3.000	0.375	0.375	1.375	2.190	3.875	4.625	0.625	7.000	8.000	7.625
2-1/2	3	1	1.125	3.000	0.375	0.375	2.125	2.190	3.875	4.625	1.000	8.125	9.500	9.125
	1	1	1.125	3.750	0.625	0.438	1.875	2.760	4.688	5.500	0.750	9.375	10.750	10.125
3-1/4	3	1-3/8	1.625	3.750	0.625	0.438	2.625	2.760	4.688	5.500	1.000	9.750	11.375	10.750
	1	1	1.125	4.500	0.625	0.438	1.875	3.320	5.438	6.250	0.750	9.750	11.125	10.500
4	3	1-3/8	1.625	4.500	0.625	0.438	2.625	3.320	5.438	6.250	1.000	10.000	11.625	11.000
	1	1	1.125	5.500	0.625	0.563	1.875	4.100	6.625	7.625	0.750	10.500	11.875	11.250
5	3	1-3/8	1.625	5.500	0.625	0.563	2.625	4.100	6.625	7.625	1.000	10.875	12.500	11.875

B

Tie Rod Pneumatic Cylinders

4MA Series

4MAJ Series

2MNR Series

ACVB Option

LPSO Option

P1D Series



For inventory, lead time, and kit lookup, visit www.pdnplu.com

Tie Rods Extended Head End Mount

Style TB
 (NFPA MX3)

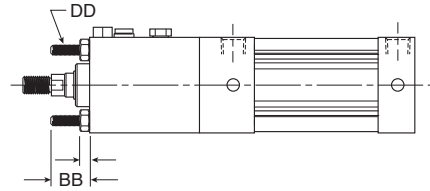
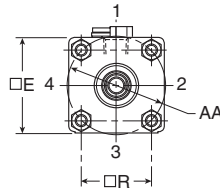
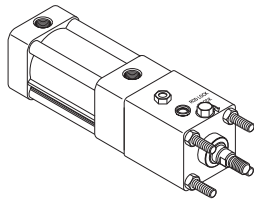

Tie Rods Extended Cap End Mount

Style TC
 (NFPA MX2)

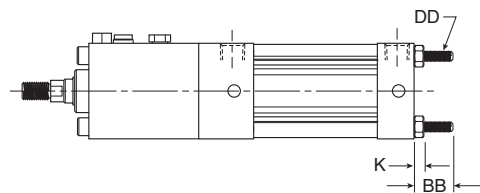
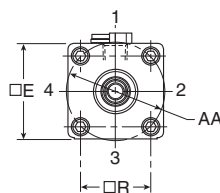
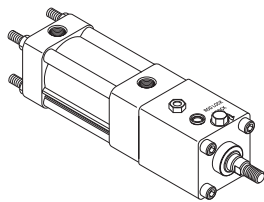

Tie Rods Extended Both Ends Mount

Style TD
 (NFPA MX1)

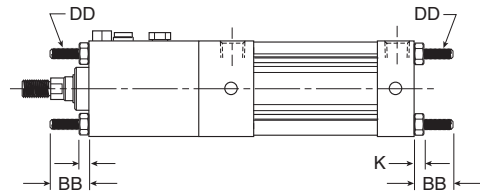
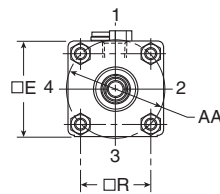
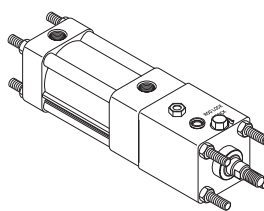

Styles TB, TC and TD Dimensions

Bore size	Rod no.	Rod dia. MM	AA	BB	DD	E	K	R
1-1/2	1	5/8	2.020	1.000	1/4 - 28	2.000	0.250	1.430
	3	1	2.600	1.125	5/16 - 24	2.500	0.313	1.840
2	1	5/8	2.600	1.125	5/16 - 24	2.500	0.313	1.840
	3	1	3.100	1.125	5/16 - 24	3.000	0.313	2.190
2-1/2	1	5/8	3.100	1.125	5/16 - 24	3.000	0.313	2.190
	3	1	3.900	1.375	3/8 - 24	3.750	0.375	2.760
3-1/4	1	1	3.900	1.375	3/8 - 24	3.750	0.375	2.760
	3	1-3/8	4.700	1.375	3/8 - 24	4.500	0.375	3.320
4	1	1	4.700	1.375	3/8 - 24	4.500	0.375	3.320
	3	1-3/8	5.800	1.813	1/2 - 20	5.500	0.438	4.100
5	1	1	5.800	1.813	1/2 - 20	5.500	0.438	4.100
	3	1-3/8						

B
 Tie Rod Pneumatic Cylinders
 4MA Series
 4MAJ Series
 2MNR Series
 ACVB Option
 LPSO Option
 P1D Series



For inventory, lead times, and kit lookup, visit www.pdnplu.com

Style C, F

Tie Rod Pneumatic Cylinders 4MAJ Series – 1-1/2" to 5" Bore Size

Side Lug Mount

Style C
(NFPA MS2)

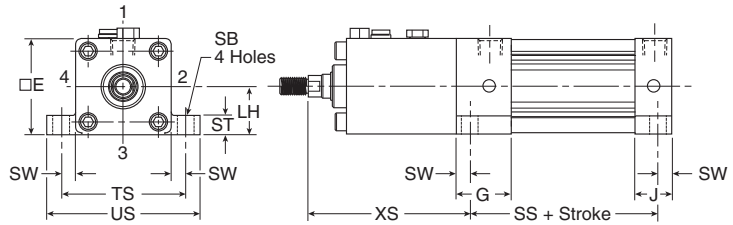
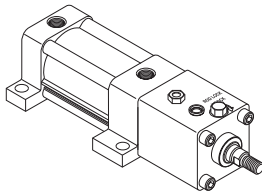

Style C Dimensions

Bore size	Rod no.	Rod dia. MM	E	G	J	+/-0.003 LH	SB	ST	SW	TS	US	XS	Add stroke SS
1-1/2	1	5/8	2.000	1.438	0.938	0.993	0.438	0.500	0.375	2.750	3.500	4.000	2.875
	3	1	2.500	1.375	0.937	1.243	0.438	0.500	0.375	3.250	4.000	5.625	2.875
2	1	5/8	2.500	1.375	0.937	1.243	0.438	0.500	0.375	3.250	4.000	4.250	2.875
	3	1	2.500	1.375	0.937	1.243	0.438	0.500	0.375	3.250	4.000	5.625	2.875
2-1/2	1	5/8	3.000	1.344	0.938	1.493	0.438	0.500	0.375	3.750	4.500	4.250	3.000
	3	1	3.000	1.344	0.938	1.493	0.438	0.500	0.375	3.750	4.500	5.750	3.000
3-1/4	1	1	3.750	1.594	1.125	1.868	0.563	0.750	0.500	4.750	5.750	6.375	3.250
	3	1-3/8	3.750	1.594	1.125	1.868	0.563	0.750	0.500	4.750	5.750	7.000	3.250
4	1	1	4.500	1.594	1.125	2.243	0.563	0.750	0.500	5.500	6.500	6.750	3.250
	3	1-3/8	4.500	1.594	1.125	2.243	0.563	0.750	0.500	5.500	6.500	7.250	3.250
5	1	1	5.500	1.594	1.219	2.743	0.813	1.000	0.688	6.875	8.250	7.438	3.125
	3	1-3/8	5.500	1.594	1.219	2.743	0.813	1.000	0.688	6.875	8.250	8.063	3.125

Side Tap Mount

Style F
(NFPA MS4)

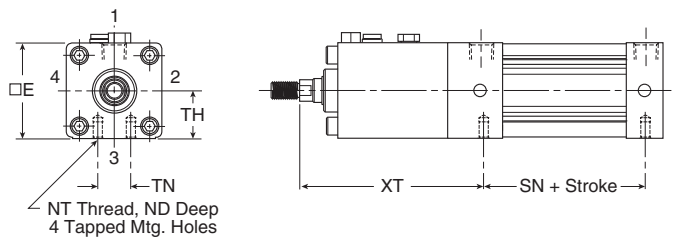
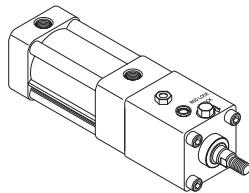

Style F Dimensions

Bore size	Rod no.	Rod dia. MM	E	ND	NT	+/-0.003 TH	TN	XT	Add stroke SN
1-1/2	1	5/8	2.000	0.375	1/4 - 20	0.993	0.625	4.563	2.250
	3	1	2.500	0.375	5/16 - 18	1.243	0.875	6.188	2.250
2	1	5/8	2.500	0.438	5/16 - 18	1.243	0.875	4.813	2.250
	3	1	2.500	0.375	5/16 - 18	1.243	0.875	6.188	2.250
2-1/2	1	5/8	3.000	0.625	3/8 - 16	1.493	1.250	4.813	2.375
	3	1	3.000	0.625	3/8 - 16	1.493	1.250	6.313	2.375
3-1/4	1	1	3.750	0.750	1/2 - 13	1.868	1.500	6.938	2.625
	3	1-3/8	3.750	0.750	1/2 - 13	1.868	1.500	7.563	2.625
4	1	1	4.500	0.750	1/2 - 13	2.243	2.063	7.313	2.625
	3	1-3/8	4.500	0.750	1/2 - 13	2.243	2.063	7.813	2.625
5	1	1	5.500	0.938	5/8 - 11	2.743	2.688	7.813	2.875
	3	1-3/8	5.500	0.938	5/8 - 11	2.743	2.688	8.438	2.875

B

Tie Rod Pneumatic Cylinders

4MA Series

4MAJ Series

2MNR Series

ACVB Option

LPSO Option

P1D Series



For inventory, lead time, and kit lookup, visit www.pdnplu.com

Style CB, G

**Tie Rod Pneumatic Cylinders
4MAJ Series – 1-1/2" to 5" Bore Size**

Side End Angle Mount

Style CB
(NFFPA MS1)

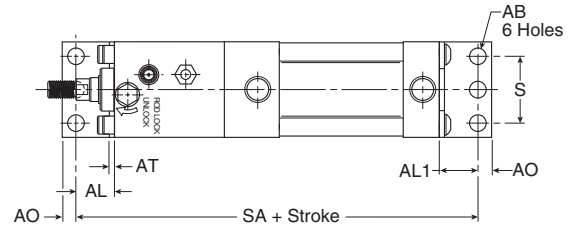
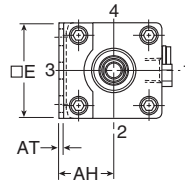
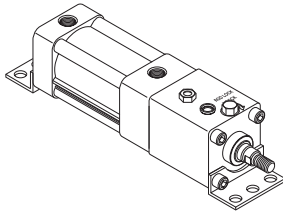

Style CB Dimensions

Bore size	Rod no.	Rod dia. MM	AB	AH	AL	AL1	AO	AT	E	S	Add stroke	
											SA	SA
1-1/2	1	5/8	0.438	1.188	1.000	1.000	0.375	0.125	2.000	1.250	8.250	
	3	1	0.438	1.438	1.000	1.000	0.375	0.125	2.500	1.750	8.500	
2	1	5/8	0.438	1.625	1.000	1.000	0.375	0.125	3.000	2.250	8.625	
	3	1	0.438	1.625	1.000	1.000	0.375	0.125	3.000	2.250	9.750	
2-1/2	1	5/8	0.563	1.938	1.250	1.250	0.500	0.125	3.750	2.750	11.250	
	3	1-3/8	0.563	1.938	1.250	1.250	0.500	0.125	3.750	2.750	11.625	
3-1/4	1	1	0.563	2.250	1.875	1.250	0.500	0.125	4.500	3.500	12.250	
	3	1-3/8	0.563	2.250	1.875	1.250	0.500	0.125	4.500	3.500	12.500	
4	1	1	0.688	2.750	1.375	1.375	0.625	0.188	5.500	4.250	12.625	
	3	1-3/8	0.688	2.750	1.375	1.375	0.625	0.188	5.500	4.250	13.000	

Side End Lug Mount

Style G
(NFFPA MS7)

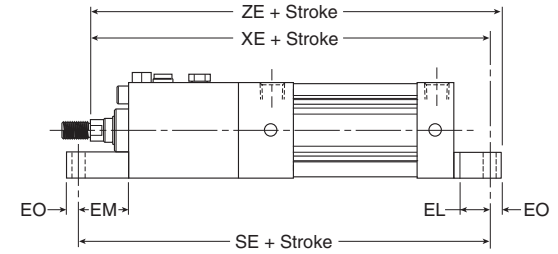
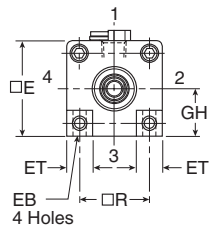
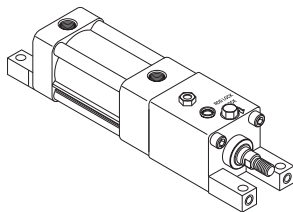

Style G Dimensions

Bore size	Rod no.	Rod dia. MM	E	EB	EL	EM	EO	ET	+/- .003 GH R	Add stroke			
										SE	XE	ZE	
1-1/2	1	5/8	2.000	0.281	0.750	1.125	0.250	0.563	0.993	1.430	8.125	8.000	8.250
	3	1	2.500	0.344	0.938	1.313	0.313	0.688	1.243	1.840	8.750	8.438	8.750
2	1	5/8	2.500	0.344	0.938	1.313	0.313	0.688	1.243	1.840	9.750	9.813	10.125
	3	1	2.500	0.344	0.938	1.313	0.313	0.688	1.243	1.840	9.750	9.813	10.125
2-1/2	1	5/8	3.000	0.344	1.063	1.438	0.313	0.813	1.493	2.190	9.125	8.688	9.000
	3	1	3.000	0.344	1.063	1.438	0.313	0.813	1.493	2.190	10.250	10.188	10.500
3-1/4	1	1	3.750	0.406	0.875	1.500	0.375	1.000	1.868	2.760	11.125	11.000	11.375
	3	1-3/8	3.750	0.406	0.875	1.500	0.375	1.000	1.868	2.760	11.500	11.625	12.000
4	1	1	4.500	0.406	1.000	1.625	0.375	1.188	2.243	3.320	11.750	11.500	11.875
	3	1-3/8	4.500	0.406	1.000	1.625	0.375	1.188	2.243	3.320	12.000	12.000	12.375



For inventory, lead times, and kit lookup, visit www.pdnplu.com

Style BB, BC

**Tie Rod Pneumatic Cylinders
4MAJ Series – 1-1/2" to 5" Bore Size**

Cap Fixed Clevis Mount

Style BB
(NFPA MP1)

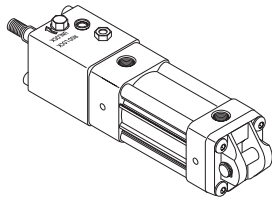

NOTE: For maximum swivel angle of BB mount with rear mounting plate, please reference cylinder accessories on page B80.

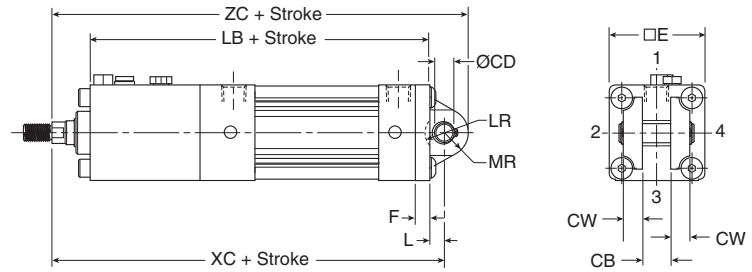

Cap Detachable Clevis Mount

Style BC
(NFPA MP2)

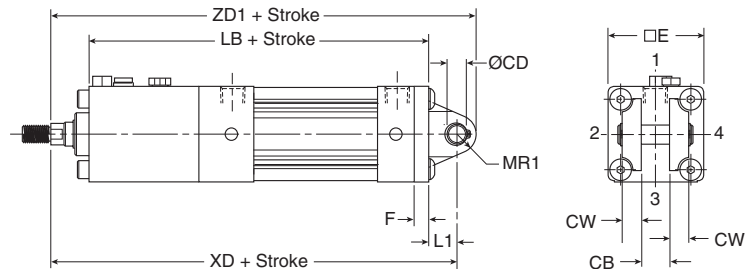
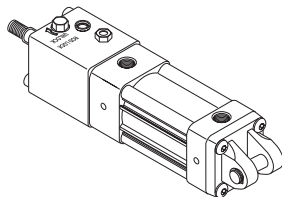

Styles BB and BC Dimensions

Bore size	Rod no.	Rod dia. MM	CB	+0.000 -0.002 CD	CW	E	F	L	L1	LR	MR	MR1	Add stroke				
													LB	XC	XD	ZC	ZD1
1-1/2	1	5/8	0.750	0.501	0.500	2.000	0.375	0.375	0.750	0.750	0.625	0.500	6.625	8.000	8.375	8.625	8.875
	2	1	0.750	0.501	0.500	2.500	0.375	0.375	0.750	0.750	0.625	0.500	6.875	8.250	8.625	8.875	9.125
2	3	1	0.750	0.501	0.500	2.500	0.375	0.375	0.750	0.750	0.625	0.500	7.875	9.625	10.000	10.250	10.500
	1	5/8	0.750	0.501	0.500	3.000	0.375	0.375	0.750	0.750	0.625	0.500	7.000	8.375	8.750	9.000	9.250
2-1/2	3	1	0.750	0.501	0.500	3.000	0.375	0.375	0.750	0.750	0.625	0.500	8.125	9.875	10.250	10.500	10.750
	1	5/8	1.250	0.751	0.625	3.750	0.625	0.625	1.250	1.000	0.938	0.750	9.375	11.375	12.000	12.313	12.750
3-1/4	3	1-3/8	1.250	0.751	0.625	3.750	0.625	0.625	1.250	1.000	0.938	0.750	9.750	12.000	12.625	12.938	13.375
	1	1	1.250	0.751	0.625	4.500	0.625	0.625	1.250	1.000	0.938	0.750	9.750	11.750	12.375	12.688	13.125
4	3	1-3/8	1.250	0.751	0.625	4.500	0.625	0.625	1.250	1.000	0.938	0.750	10.000	12.250	12.875	13.188	13.625
	1	1	1.250	0.751	0.625	5.500	0.625	0.625	1.250	1.000	0.938	0.750	10.500	12.500	13.125	13.438	13.875
5	3	1-3/8	1.250	0.751	0.625	5.500	0.625	0.625	1.250	1.000	0.938	0.750	10.875	13.125	13.750	14.063	14.500

B

Tie Rod Pneumatic Cylinders

4MA Series

4MAJ Series

2MNR Series

ACVB Option

LPSO Option

P1D Series



For inventory, lead time, and kit lookup, visit www.pdnplu.com

Tie Rod Pneumatic Cylinders 4MAJ Series – 1-1/2" to 5" Bore Size

Cap Detachable Eye Mount

Style BE
(NFPA MP4)

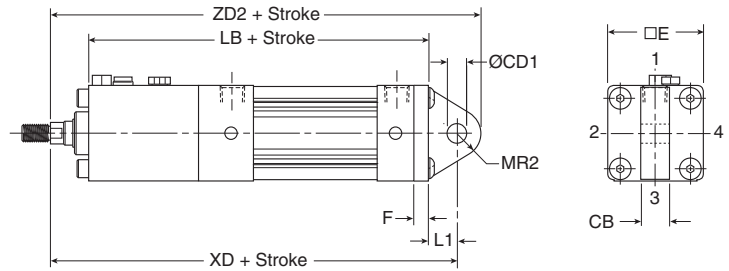
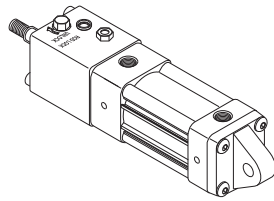

Style BE Dimensions

Bore size	Rod no.	Rod dia. MM	CB	+0.02 +0.04 CD1	E	F	L1	MR2	Add Stroke		
									LB	XD	ZD2
1-1/2	1	5/8	0.750	0.500	2.000	0.375	0.750	0.625	6.625	8.375	9.000
	3	1	0.750	0.500	2.500	0.375	0.750	0.625	7.875	10.000	10.625
2	1	5/8	0.750	0.500	2.500	0.375	0.750	0.625	6.875	8.625	9.250
	3	1	0.750	0.500	2.500	0.375	0.750	0.625	7.875	10.000	10.625
2-1/2	1	5/8	0.750	0.500	3.000	0.375	0.750	0.688	7.000	8.750	9.438
	3	1	0.750	0.500	3.000	0.375	0.750	0.688	8.125	10.250	10.938
3-1/4	1	1	1.250	0.750	3.750	0.625	1.250	0.875	9.375	12.000	12.875
	3	1-3/8	1.250	0.750	3.750	0.625	1.250	0.875	9.750	12.625	13.500
4	1	1	1.250	0.750	4.500	0.625	1.250	0.875	9.750	12.375	13.250
	3	1-3/8	1.250	0.750	4.500	0.625	1.250	0.875	10.000	12.875	13.750
5*	1	1	1.250	0.750	5.500	0.625	1.250	0.875	10.500	13.125	14.000
	3	1-3/8	1.250	0.750	5.500	0.625	1.250	0.875	10.875	13.750	14.625

Intermediate Trunnion Mount

Style DD
(NFPA MT4)

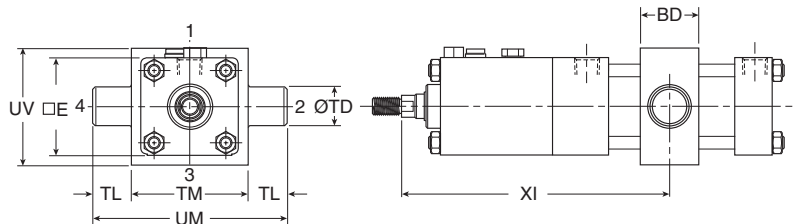
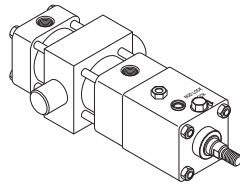

Note: Tie rod nuts for Style DD have a slot instead of external hex.

Note: Style DD requires minimum stroke per table.

Style DD Dimensions

Bore size	Rod no.	Rod dia. MM	E	BD	+0.00 -0.01 TD	TL	TM	UM	UV	Min. XI	Min. stroke
2	1	5/8	2.500	1.500	1.000	1.000	3.000	5.000	3.000	6.00	4.000
	3	1	2.500	1.500	1.000	1.000	3.000	5.000	3.000	7.38	4.000
2-1/2	1	5/8	3.000	1.500	1.000	1.000	3.500	5.500	3.500	5.97	3.875
	3	1	3.000	1.500	1.000	1.000	3.500	5.500	3.500	7.47	3.875
3-1/4	1	1	3.750	2.000	1.000	1.000	4.500	6.500	4.250	8.469	4.375
	3	1-3/8	3.750	2.000	1.000	1.000	4.500	6.500	4.250	9.094	4.375
4	1	1	4.500	2.000	1.000	1.000	5.250	7.250	5.000	8.844	4.875
	3	1-3/8	4.500	2.000	1.000	1.000	5.250	7.250	5.000	9.344	4.875
5	1	1	5.500	2.000	1.000	1.000	6.250	8.250	6.000	9.344	5.125
	3	1-3/8	5.500	2.000	1.000	1.000	6.250	8.250	6.000	9.969	5.125



For inventory, lead times, and kit lookup, visit www.pdnplu.com

Style D, DB

**Tie Rod Pneumatic Cylinders
4MAJ Series – 1-1/2" to 5" Bore Size**

Head Trunnion Mount

Style D
(NFPA MT1)

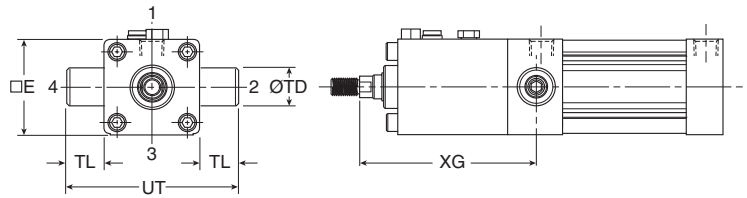
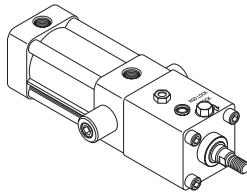

Cap Trunnion Mount

Style DB
(NFPA MT2)

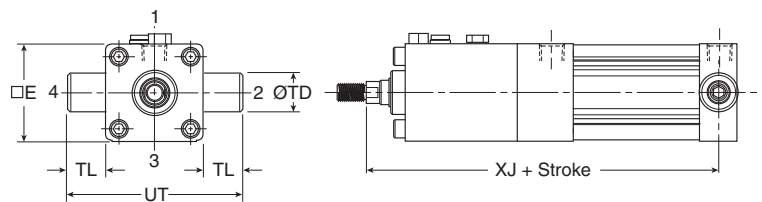
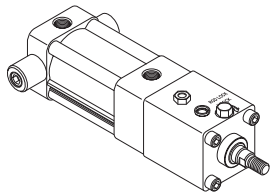

Styles D and DB Dimensions

Bore size	Rod no.	Rod dia. MM	E	+0.000 -0.001 TD	TL	UT	XG	XJ
1-1/2	1	5/8	2.000	1.000	1.000	4.000	4.375	6.750
	3	1	2.500	1.000	1.000	4.500	6.000	8.375
2	1	5/8	2.500	1.000	1.000	4.500	4.625	7.000
	3	1	2.500	1.000	1.000	4.500	6.000	8.375
2-1/2	1	5/8	3.000	1.000	1.000	5.000	4.625	7.125
	3	1	3.000	1.000	1.000	5.000	6.125	8.625
3-1/4	1	1	3.750	1.000	1.000	5.750	6.750	9.500
	3	1-3/8	3.750	1.000	1.000	5.750	7.375	10.125
4	1	1	4.500	1.000	1.000	6.500	7.125	9.875
	3	1-3/8	4.500	1.000	1.000	6.500	7.625	10.375
5	1	1	5.500	1.000	1.000	7.500	7.625	10.625
	3	1-3/8	5.500	1.000	1.000	7.500	8.250	11.250

B

Tie Rod Pneumatic Cylinders

4MA Series

4MAJ Series

2MNR Series

ACVB Option

LPSO Option

P1D Series



For inventory, lead time, and kit lookup, visit www.pdnplu.com

Style T

**Tie Rod Pneumatic Cylinders
4MAJ Series – 6" to 8" Bore Sizes**

No Mount

Style T
(NFPA MX0)

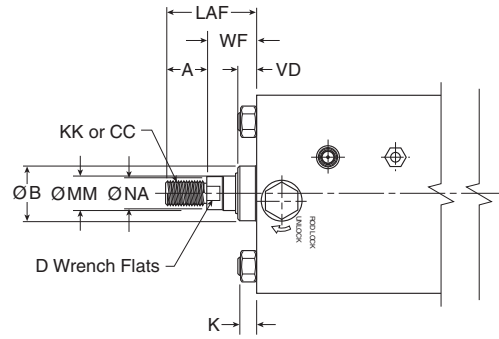
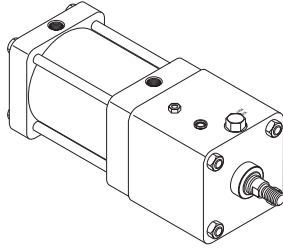

For dimensions of all standard rod end styles, see next page.

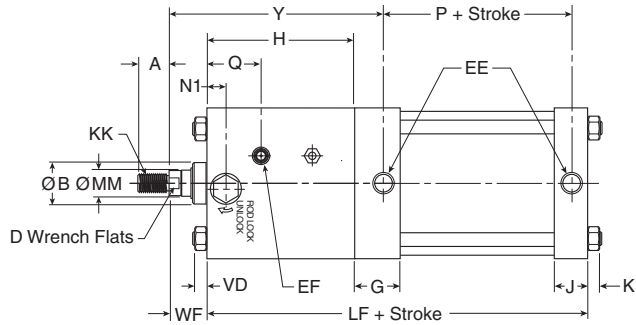
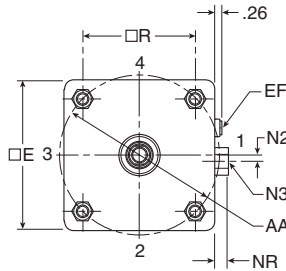

Style T Dimensions

Bore size	Rod no.	Rod dia. MM	Thread		Style 6	A	AA	B	D	E	EE (NPTF)	EF (NPTF)	G	H	J
			Style 8 CC	Style 4 & 9 KK											
6	1	1-3/8	1-1/4 - 12	1 - 14	1-3/8 - 14	1.625	6.900	1.999	1-1/8	6.500	3/4	1/4	1.910	6.375	1.410
	3	1-3/4	1-1/2 - 12	1-1/4 - 12	1-3/4 - 12	2.000	6.900	2.374	1-1/2	6.500	3/4	1/4	1.910	6.875	1.410
8	1	1-3/8	1-1/4 - 12	1 - 4	1-3/8 - 14	1.625	9.100	1.999	1-1/8	8.500	3/4	1/4	1.810	6.625	1.440
	3	1-3/4	1-1/2 - 12	1-1/4 - 12	1-3/4 - 12	2.000	9.100	2.374	1-1/2	8.500	3/4	1/4	1.810	7.125	1.440

Bore size	Rod no.	Rod dia. MM	Hex											Add stroke		
			K	LAF	N1	N2	N3	NA	NR	Q	R	VD	WF	Y	LF	P
6	1	1-3/8	0.438	3.250	1.165	0.177	1-5/16	1.313	0.750	2.705	4.880	0.755	1.625	9.188	11.375	3.125
	3	1-3/4	0.438	3.875	1.495	0.177	1-5/16	1.688	0.740	3.055	4.880	0.875	1.875	9.938	11.875	3.125
8	1	1-3/8	0.563	3.250	1.305	0.177	1-5/16	1.313	0.740	2.885	6.440	0.755	1.625	9.375	11.750	3.250
	3	1-3/4	0.563	3.875	1.570	0.177	1-5/16	1.688	0.740	3.145	6.440	0.875	1.875	10.125	12.250	3.250



For inventory, lead times, and kit lookup, visit www.pdnplu.com

Rod End Thread Styles

Tie Rod Pneumatic Cylinders 4MAJ Series – 6" to 8" Bore Sizes

Rod End

Thread Style 4

(NFPA Style SM)
Small Male

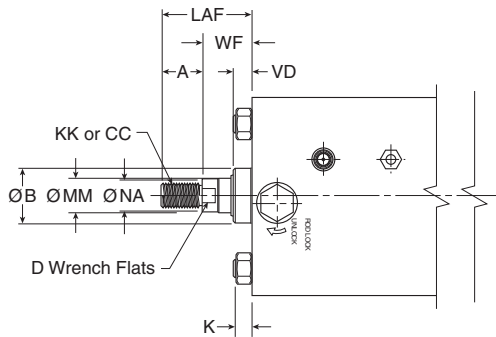

Thread Style 8

(NFPA Style IM)
Intermediate Male

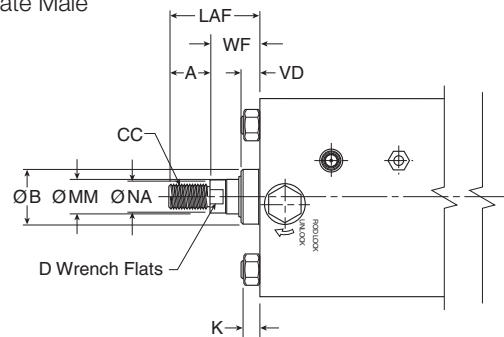

Thread Style 9

(NFPA Style SF)
Short Female

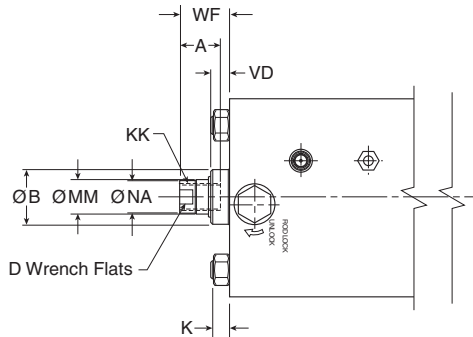

Thread Style 55

For use with Split Coupler
(please reference page B77 for more information)

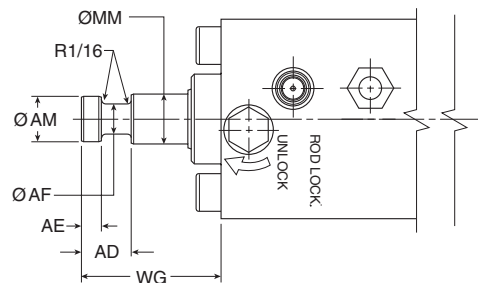

Thread Style 3 - "Special Thread"

Special threads, rod extensions, rod eyes, blanks, etc. are also available.
To order, specify "Style 3" and give desired dimensions for KK or CC, A and W or WF.
If otherwise special, please supply dimensioned sketch.

Rod End Dimensions

Bore size	Rod no.	Rod dia. MM	Thread					A	AD	AE	AF	AM	B	D	K	LAF	NA	VD	WF	WG
			Style 8 CC	Style 4 & 9 KK	Style 6	Style 4 & 9	Style 4 & 9													
6	1	1-3/8	1-1/4 - 12	1 - 14	1-3/8 - 14	1.625	1.063	0.375	0.875	1.320	1.999	1-1/8	0.438	3.250	1.313	0.755	1.625	2.750		
	3	1-3/4	1-1/2 - 12	1-1/4 - 12	1-3/4 - 12	2.000	1.313	0.500	1.125	1.700	2.374	1-1/2	0.438	3.875	1.688	0.875	1.875	3.125		
8	1	1-3/8	1-1/4 - 12	1 - 14	1-3/8 - 14	1.625	1.063	0.375	0.875	1.320	1.999	1-1/8	0.563	3.250	1.313	0.755	1.625	2.750		
	3	1-3/4	1-1/2 - 12	1-1/4 - 12	1-3/4 - 12	2.000	1.313	0.500	1.125	1.700	2.374	1-1/2	0.563	3.875	1.688	0.875	1.875	3.125		

B

Tie Rod Pneumatic Cylinders

4MA Series

4MAJ Series

2MNR Series

ACVB Option

LPSO Option

P1D Series



For inventory, lead time, and kit lookup, visit www.pdnplu.com

K-type Cylinder

To determine dimensions for a double rod end cylinder, first refer to the desired single rod end mounting style cylinder shown in this catalog section. After selecting the necessary dimensions from that drawing, return to this page and supplement the single rod end dimensions with those shown in the drawings and dimension table below. Note that double rod end cylinders have a head dimension G at both ends, and

Tie Rod Pneumatic Cylinders 4MAJ Series – 6" to 8" Bore Sizes

that LG replaces LF, PK replaces P, etc. The double rod end dimensions differ from, or are in addition to, those for single rod cylinders.

When a double rod end cylinder has two different rod ends, please clearly state which rod end is to be available at which head end.

K-type 6" to 8" Bore Size

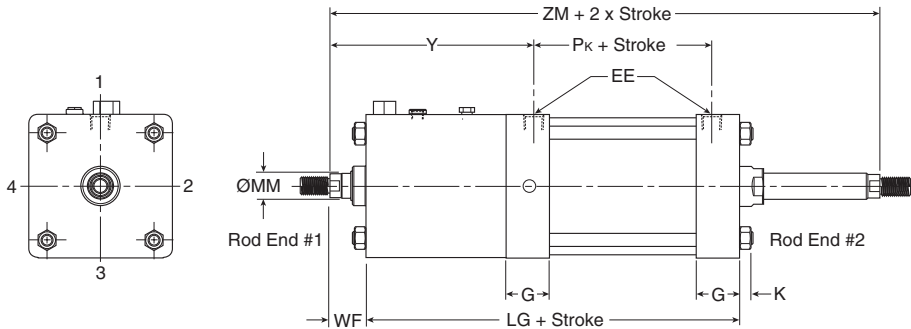
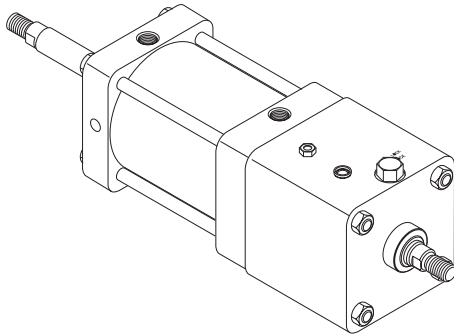

Mounting styles for single rod models	Corresponding mounting styles for double rod models
C	KC
CB	KCB
D	KD
DD	KDD
F	KF
J	KJ
T	KT
TB	KTB
TD	KTD

Style KT Dimensions

Bore size	Rod no.	Rod dia. MM	EE (NPTF) G	K	WF	Y	Add Stroke						Add 2X Stroke ZM	
							LG	Pk	SAk	XAk	SSk	SNk		
6	1	1-3/8	3/4	1.910	0.438	1.625	9.188	11.875	3.125	14.625	14.875	4.125	3.125	15.125
	3	1-3/4	3/4	1.910	0.438	1.875	9.938	12.375	3.125	15.125	15.625	4.125	3.125	16.125
8	1	1-3/8	3/4	1.810	0.563	1.625	9.375	12.125	3.250	15.750	15.563	4.125	3.125	15.375
	3	1-3/4	3/4	1.810	0.563	1.875	10.125	12.625	3.250	16.250	16.313	4.125	3.125	16.375
Replaces Dimension On								LF	P	SA	XA	SS	SN	-
Single Rod Mounting Styles								All Styles	All Styles	CB	CB	C	F	All

B
 Tie Rod Pneumatic Cylinders
 4MA Series
 4MAJ Series
 2MNR Series
 ACVB Option
 LPSO Option
 P1D Series



For inventory, lead times, and kit lookup, visit www.pdnplu.com

Style J, H

Tie Rod Pneumatic Cylinders 4MAJ Series – 6" to 8" Bore Sizes

Head Rectangular Flange Mount

Style J
(NFPA MF1)
(only 6" Bore)

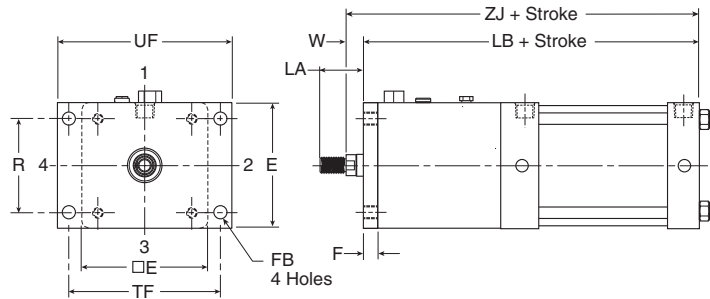
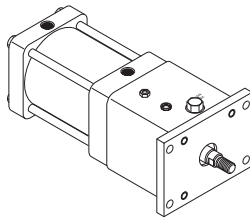

Note: Style J has a W dimension instead of WF and a LA dimension instead of LAF because of the flange installation. Please use dimensions W and LA regarding rod ends only for Style J.
For reference, $WF = W + F$ and $LA = W + A$.

Cap Rectangular Flange Mount

Style H
(NFPA MF2)
(only 6" Bore)

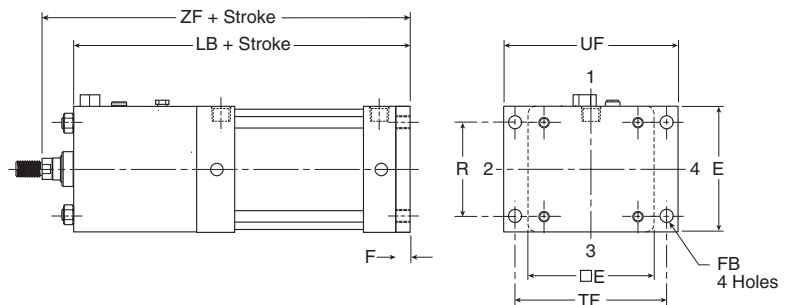
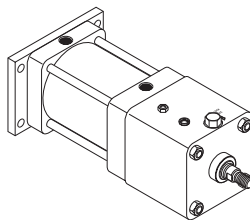

Styles J and H Dimensions

Bore size	Rod no.	Rod dia. MM	Add stroke											
			A	E	F	FB	LA	R	TF	UF	W	LB	ZF	ZJ
6	1	1-3/8	1.625	6.500	0.750	0.563	2.500	4.880	7.625	8.625	0.875	12.125	13.750	13.000
	3	1-3/4	2.000	6.500	0.750	0.563	3.125	4.880	7.625	8.625	1.125	12.625	14.500	13.750

B	Tie Rod Pneumatic Cylinders
	4MA Series
	4MAJ Series
	2MNR Series
	ACVB Option
	LPSO Option
	P1D Series



For inventory, lead time, and kit lookup, visit www.pdnplu.com

Tie Rods Extended Head End Mount

Style TB
 (NFPA MX3)

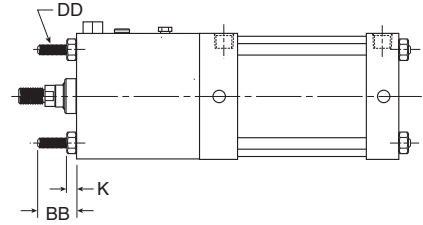
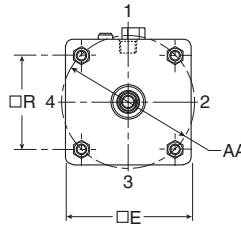
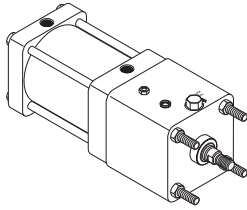

Tie Rods Extended Cap End Mount

Style TC
 (NFPA MX2)

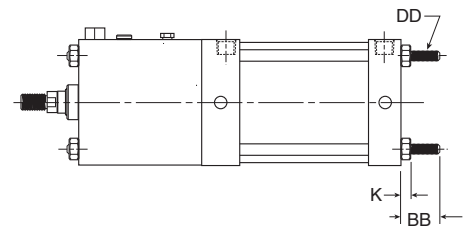
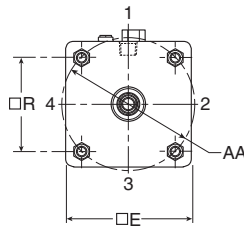
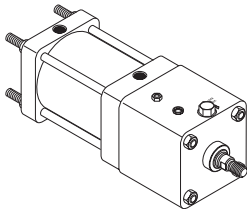

Tie Rods Extended Both Ends Mount

Style TD
 (NFPA MX1)

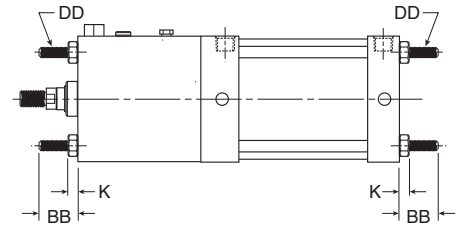
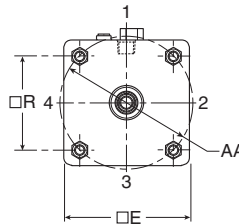
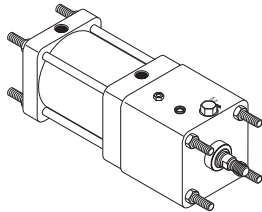

Styles TB, TC and TD Dimensions

Bore size	Rod no.	Rod dia. MM	AA	BB	DD	E	K	R
6	1	1-3/8	6.900	1.813	1/2-20	6.500	0.438	4.880
	3	1-3/4	6.900	1.813	1/2-20	6.500	0.438	4.880
8	1	1-3/8	9.100	2.313	5/8-18	8.500	0.563	6.440
	3	1-3/4	9.100	2.313	5/8-18	8.500	0.563	6.440

B
 Tie Rod Pneumatic Cylinders
 4MA Series
 4MAJ Series
 2MNR Series
 ACVB Option
 LPSO Option
 P1D Series



For inventory, lead times, and kit lookup, visit www.pdnplu.com

Side End Angle Mount

Style CB
 (NFPA MS1)

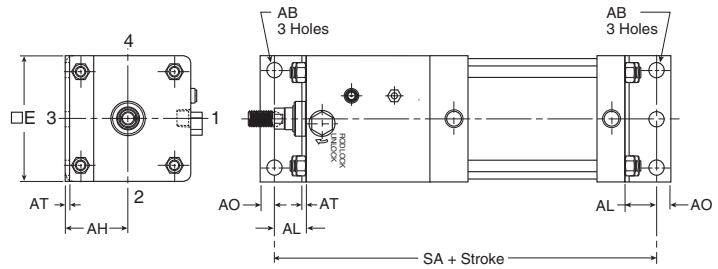
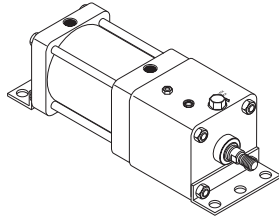

Style CB Dimensions

Bore size	Rod no.	Rod dia. MM	AB	AH	AL	AO	AT	E	S	Add stroke SA
6	1	1-3/8	0.813	3.250	1.375	0.625	0.188	6.500	5.250	14.125
	3	1-3/4	0.813	3.250	1.375	0.625	0.188	6.500	5.250	14.625
8	1	1-3/8	0.813	4.250	1.813	0.688	0.250	8.500	7.125	15.375
	3	1-3/4	0.813	4.250	1.813	0.688	0.250	8.500	7.125	15.875

Side Tap Mount

Style F
 (NFPA MS4)

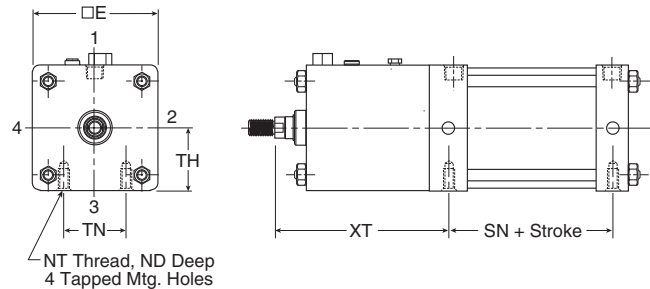
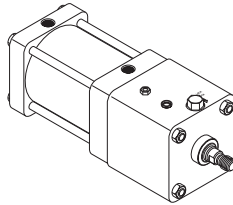

Style F Dimensions

Bore size	Rod no.	Rod dia. MM	E	ND	NT	+/- .003 TH	TN	XT	Add stroke SN
6	1	1-3/8	6.500	1.125	3/4-10	3.243	3.250	9.188	3.125
	3	1-3/4	6.500	1.125	3/4-10	3.243	3.250	9.938	3.125
8	1	1-3/8	8.500	1.125	3/4-10	4.243	4.500	9.438	3.250
	3	1-3/4	8.500	1.125	3/4-10	4.243	4.500	10.188	3.250

Side Lug Mount

Style C
 (NFPA MS2)

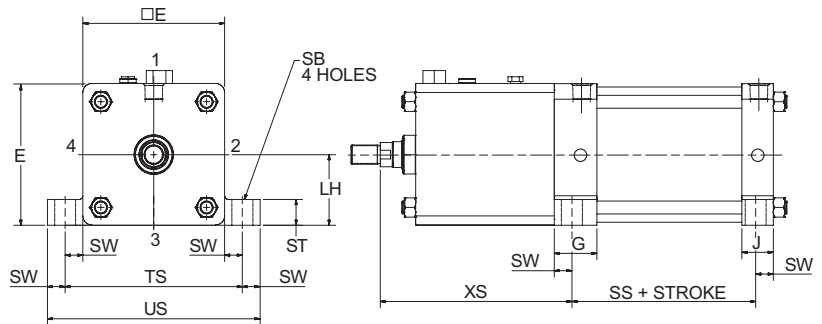
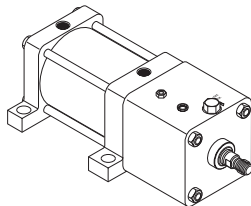

Style C Dimensions

Bore size	Rod no.	Rod dia. MM	E	G	J	+/- .003 LH	SB	ST	SW	TS	US	XS	Add stroke SS
6	1	1-3/8	6.500	1.910	1.410	3.243	0.813	1.000	0.688	7.875	9.250	8.688	3.625
	3	1-3/4	6.500	1.910	1.410	3.243	0.813	1.000	0.688	7.875	9.250	9.438	3.625
8	1	1-3/8	8.500	1.810	1.440	4.243	0.813	1.000	0.688	9.875	11.250	8.938	3.750
	3	1-3/4	8.500	1.810	1.440	4.243	0.813	1.000	0.688	9.875	11.250	9.688	3.750

B

Tie Rod Pneumatic Cylinders

4MA Series

4MAJ Series

2MNR Series

ACVB Option

LPSO Option

P1D Series



For inventory, lead time, and kit lookup, visit www.pdnplu.com

Cap Fixed Clevis

Style BB
 (NFPA MP1)

NOTE: For maximum swivel angle of BB mount with rear mounting plate, please reference cylinder accessories on page B80.

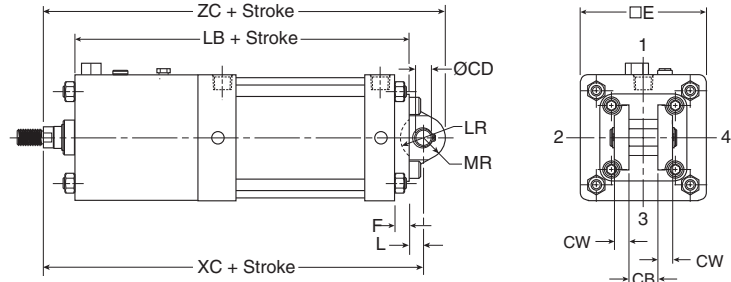
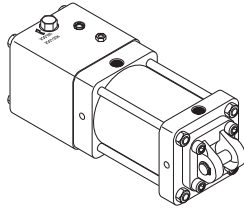

Cap Detachable Clevis

Style BC
 (NFPA MP2)

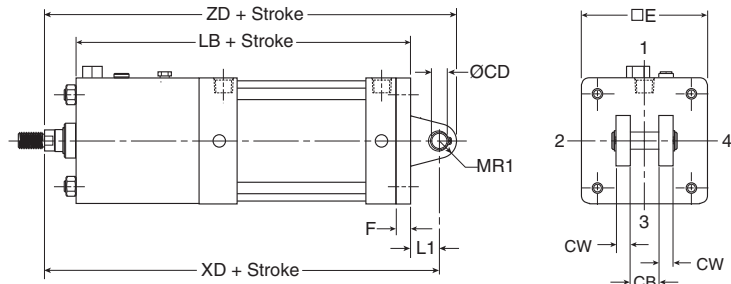
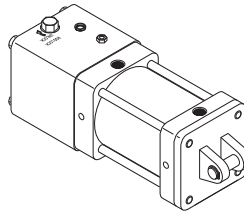

Styles BB and BC Dimensions

Bore size	Rod no.	Rod dia. MM	CB	+0.002 -0.002 CD	CW	E	F	L	L1	LR	MR	MR1	Add stroke LB	XC	XD	ZC	ZD
6	1	1-3/8	1.500	1.001	0.750	6.500	0.750	0.750	1.500	1.250	1.125	1.000	12.125	14.500	15.250	15.625	16.250
	3	1-3/4	1.500	1.001	0.750	6.500	0.750	0.750	1.500	1.250	1.125	1.000	12.625	15.250	16.000	16.375	17.000
8	1	1-3/8	1.500	1.001	0.750	8.500	0.750	0.750	1.500	1.250	1.125	1.000	12.500	14.875	15.625	16.000	16.625
	3	1-3/4	1.500	1.001	0.750	8.500	0.750	0.750	1.500	1.250	1.125	1.000	13.000	15.625	16.375	16.750	17.375

Cap Detachable Eye Mount

Style BE
 (NFPA MP4)
 (only 6" Bore)

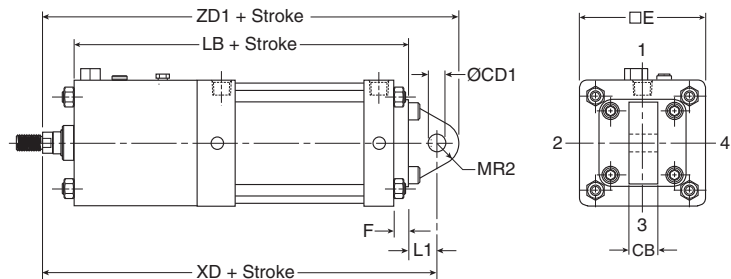
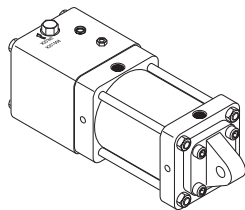

Style BE Dimensions

Bore size	Rod no.	Rod dia. MM	CB	+0.002 +0.004 CD1	E	F	L1	MR2	Add stroke LB	XD	ZD1
6	1	1-3/8	1.500	1.000	6.500	0.750	1.500	1.125	12.125	15.250	16.375
	3	1-3/4	1.500	1.000	6.500	0.750	1.500	1.125	12.625	16.000	17.125



For inventory, lead times, and kit lookup, visit www.pdnplu.com

B
 Tie Rod Pneumatic Cylinders
 4MA Series
 4MAJ Series
 2MNR Series
 ACVB Option
 LPSO Option
 P1D Series

Head Trunnion Mount

Style D
 (NFPA MT1)

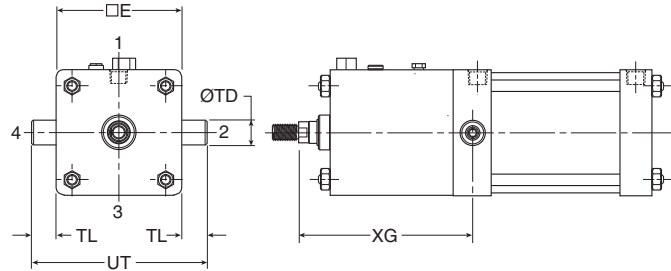
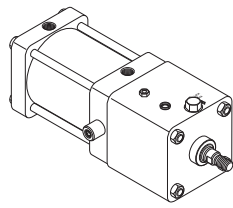

Cap Trunnion Mount

Style DB
 (NFPA MT2)

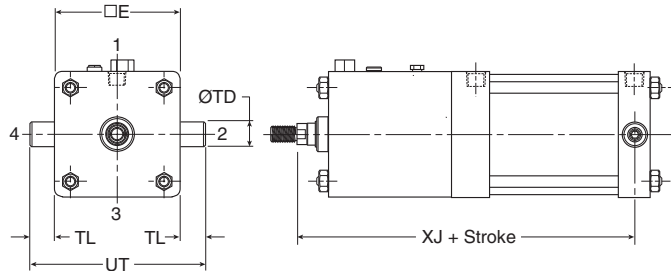
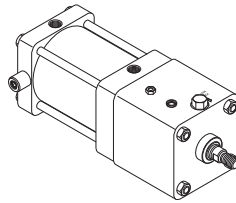

Styles D and DB Dimensions

Bore size	Rod no.	Rod dia. MM	E	+0.000 -0.001 TD	TL	UT	XG	XJ
6	1	1-3/8	6.500	1.375	1.375	9.250	9.000	12.250
	3	1-3/4	6.500	1.375	1.375	9.250	9.750	13.000
8	1	1-3/8	8.500	1.375	1.375	11.250	9.250	12.625
	3	1-3/4	8.500	1.375	1.375	11.250	10.000	13.375

Intermediate Trunnion Mount

Style DD
 (NFPA MT4)

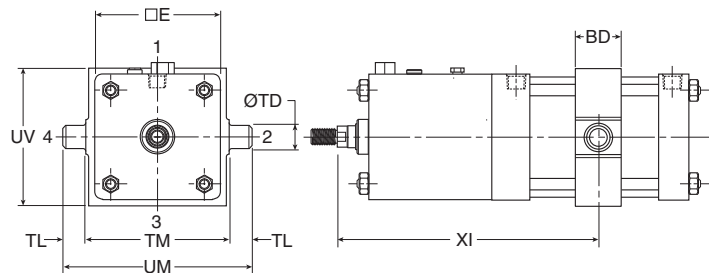
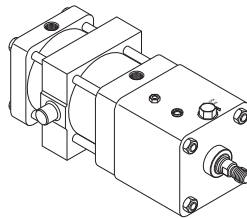

Note: Style DD requires minimum stroke per table.

Style DD Dimensions

Bore size	Rod no.	Rod dia. MM	E	BD	+0.000 -0.001 TD	TL	TM	UM	UV	Min. XI	Min. stroke
6	1	1-3/8	6.500	2.500	1.375	1.375	7.625	10.375	7.000	11.16	6.125
	3	1-3/4	6.500	2.500	1.375	1.375	7.625	10.375	7.000	11.91	6.125
8	1	1-3/8	8.500	2.500	1.375	1.375	9.750	12.500	9.500	11.31	6.500
	3	1-3/4	8.500	2.500	1.375	1.375	9.750	12.500	9.500	12.06	6.500

B
 Tie Rod Pneumatic Cylinders
 4MA Series
 4MAJ Series
 2MNR Series
 ACVB Option
 LPSO Option
 P1D Series

Kits & Accessories

See page B34 to B36.



For inventory, lead time, and kit lookup, visit www.pdnplu.com

How To Order ACVB Option

4MA ACVB

How to Order ACVB Option fully assembled to 4MA Cylinder

B
Tie Rod Pneumatic
Cylinders

4MA Series
4MAJ Series
2MNR Series
ACVB Option
LPSO Option
P1D Series

2.00 **J** **4MA** **U** **S** **1** **4** **A** **6.000**

Bore Size

1.50
2.00
2.50
3.25
4.00
5.00

Double Rod Cylinder¹
Specify "K" only if double rod cylinder is required.

Mounting Style
Specify mounting style code per available 4MA mount.

Series
4MA

Ports

U	NPTF
---	------

Piston Rod Number
See 4MA section for more details.

Stroke Length
Specify stroke length required in inches.

Cushion Head End

Blank	Non-cushioned head end
C	Cushioned head end

Seals

Blank	Standard (nitrile seals)
E	Fluorocarbon rod wiper and rod seal only
M	Metallic rod wiper, nitrile seals

Cushion Cap End

Blank	Non-cushioned cap end
C	Cushioned cap end

Cylinder Construction

Blank	Standard (extruded body, standard round lobe orientation) *
A	Extruded body, round lobe orientation rotated 90 degrees from standard *
N	Extruded body, round lobe orientation rotated 180 degrees from standard *
Z	Extruded body, round lobe orientation rotated 270 degrees from standard *
T	Aluminum round tube and carbon steel tie

Special Modification
Specify "S" for ACVB options and any other special modification other than rod end. See examples below.

Piston Rod Thread Type

A	Standard (UNF Unified Thread)
W	BSF British Fine
M	Metric (see page B78)

Rod Material and Gland Code

Blank	Standard rod and gland
H	Standard rod and HI LOAD gland
Y	17-4 PH stainless steel rod and standard gland
Z	17-4 PH stainless steel rod and HI LOAD gland
J	303 stainless steel rod and standard gland
K	303 stainless steel rod and HI LOAD gland
S	316 stainless steel rod and standard gland
T	316 stainless steel rod and HI LOAD gland

Piston Rod Thread Style

4	Small male
8	Intermediate male
9	Short female
55	For use with split coupler
3	Special (and specify all dimensions required)
6	Full male

* See Table on page B5.

Piston Type

Blank	Lipseals and magnetic ring (legacy) (standard for 4ML)
1	Lipseals, no magnetic ring (legacy)
2	Lipseals, no magnetic ring (aluminum piston)
3	Lipseals and magnetic ring (aluminum piston)
4	Bumper seals, no magnetic ring
6	Bumper seals and magnetic ring
B	Lipseals, 1/4" thick bumpers both ends
H	Lipseals, 1/4" thick bumper head end
C	Lipseals, 1/4" thick bumper cap end
D	Lipseals and magnetic ring, 1/4" thick bumpers both ends
F	Lipseals and magnetic ring, 1/4" thick bumper head end
R	Lipseals and magnetic ring, 1/4" thick bumper cap end

ACVB Minimum Stroke Requirements**

Bore	4MA
Compact Manifold	
1.50	0.500
2.00	0.500
2.50	0.438
Full Manifold	
1.50	5.813
2.00	5.813
2.50	5.750
3.25	5.500
4.00	5.500
5.00	5.250

** For desired strokes less than the minimum requirement, specify a stop tube for the cylinder assembly. Total stroke should be (desired net stroke) + (stop tube length to help exceed minimum stroke). Stop tube only available for 4MA with aluminum piston.

Example:
1.50" bore 4MA with 5.000" of desired net stroke:
Gross stroke = 5.813"
Stop tube = 0.813"
Net stroke = 5.000"

Note: place gross stroke in cylinder model number and specify stop tube length and net stroke in the item notes.

Example
2.00 CJ4MAUS14AC 6.000
S = ACVB Valve Combination
S = 3C2B54 Manifold Code
(See following page.)

Flow Control Option
Add "S = with SP37 Flow Controls" to item notes

Muffler Option
Add "S = with EM Mufflers" to item notes

For ACVB with the 2A Series, please use the 2A Series Model Code and specify the following in the item notes:
S = ACVB Valve Combination
S = (Manifold Code from following page)



For inventory, lead times, and kit lookup, visit www.pdnplu.com

ACVB Series Valve/Manifold Codes

Valve Series	
3	B3
5	B5
6	B6

Pilot Source / Pilot Exhaust	
A	Internal - Port #1 / Tapped M5 (B5, B6 only)
B	Internal - Port #1 / Vented
0	None. Remote Pilot Valve

Voltage	
4	24 VDC
5	110 VAC
X	Remote Pilot

Manifold Type / Location	
C	Compact Manifold / Cap End (For use with B3 valve only)
D	Compact Manifold / Head End (For use with B3 valve only)
F	Full Manifold / Cap End (For use with B3, B5 or B6 valves)
G	Full Manifold / Head End (For use with B3, B5 or B6 valves)

Operator Type / Function	
1	Single Solenoid / Air Return
2	Double Solenoid
3	Single Remote Pilot / Air Return
4	Double Remote Pilot

Connector / Valve Series Available	
(Connector can be rotated in 90° increments for Options A-H)	
0	None / B3, B5, B6 (Remote Pilot)
5	15mm 3-PIN DIN 43650C / B3, B5, B6 (Male Connector)
6	15mm 3-PIN DIN 43650C (rotated 180°) / B3, B5, B6 (Male Connector)
A	30mm Square 3-PIN ISO 4400 Form A / B5, B6 (Male Connector)
B	22mm Rectangular 3-PIN Type B Industrial / B5, B6 (Male Connector)
C	3-PIN Automotive Mini / B5 (Female Connector)
D	5-PIN Automotive Mini / B5 (Female Connector)
F	Hazardous Duty 1/2" Conduit 18" Leads / B5, B6
H	1/2" NPT Conduit 18" Leads / B5, B6

NOTE: Cylinders with single solenoid valves mounted at the CAP END will be NORMALLY RETRACTED. Cylinders with single solenoid valves mounted at the HEAD END will be NORMALLY EXTENDED.

Customer orientation of connector at 45 degree increments possible on Options A through H on B5 and B6 valves.

B
Tie Rod Pneumatic Cylinders
4MA Series
4MAJ Series
2MNR Series
ACVB Option
LPSO Option
P1D Series

Example: 6 F 2 A 5 5

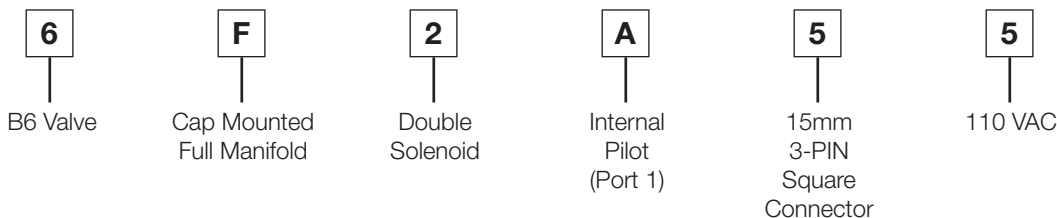

For inventory, lead time, and kit lookup, visit www.pdnplu.com

B63

Parker Hannifin Corporation
 Pneumatic Division
 Richland, Michigan
www.parker.com/pneumatics

Compact Manifold



- Standard Fluid – Dry, filtered air.
- Standard Temperature: -5°F to 120°F (-15°C to 49°C).
- Maximum 145 PSI operating pressure.
- Fits 1-1/2" through 2-1/2" Bore 4MA standard cylinders.
- Uses standard Parker fittings, tubing, and seals.
- Compact manifold accommodates B3 Series valve from Parker Pneumatic Division North America without field modification to cylinder.

Full Manifold



- Standard Fluid: Dry, filtered air.
- Standard Temperature: -5° F to 120° F (-15°C to 49°C).
- Maximum 145 PSI operating pressure.
- Fits 1-1/2" through 5" Bore 4MA standard cylinders.
- Uses standard Parker fittings, tubing, and seals.
- Full manifold accommodates B3, B5 and B6 series Parker Pneumatic valves, without field modification to cylinder (B6 series shown).
- Bolt pattern conforms to NAMUR standard on B5 and B6 valves.
- Manifold and valve do not overhang beyond head or cap fasteners.

B
Tie Rod Pneumatic Cylinders
4MA Series
4MAJ Series
2MNR Series
ACVB Option
LPSO Option
P1D Series

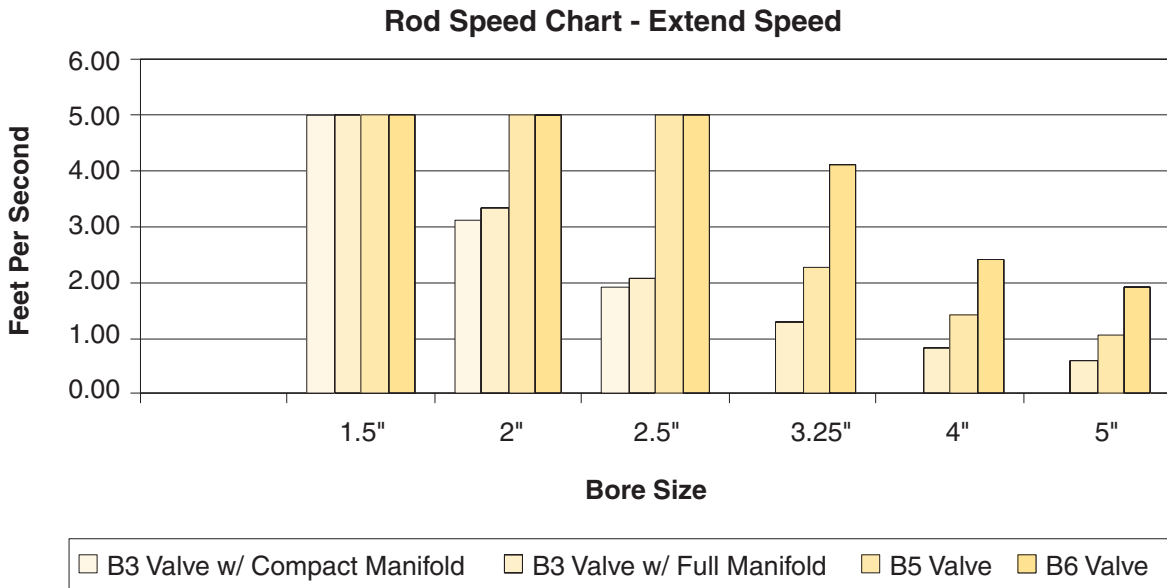

Steps to size a cylinder-valve system

Step 1. Gather the Application Parameters

- Total load
- Maximum velocity needed to move load in specified time*
- Minimum pressure available

Step 2. Size Cylinder

Use equations in engineering section of Pneumatic Actuator Catalog to calculate minimum bore size

Step 3. Size Valve/Manifold

- Use the Rod Speed Chart above
- Choose valve/manifold system that will supply maximum velocity needed for bore size chosen above

Step 4. Choose the Appropriate Model Code**

- Specify necessary valve and manifold
- Choose type of control required
- Choose type of connection and voltage required

* If maximum velocity is not easily calculated, divide the total stroke distance by the total stroke time and multiply by 2.

** See the ACVB Series Valve/Manifold Code page for more details.

B
Tie Rod Pneumatic Cylinders
4MA Series
4MAJ Series
2MNR Series
ACVB Option
LPSO Option
PID Series



For inventory, lead time, and kit lookup, visit www.pdnplu.com

Compact Manifold

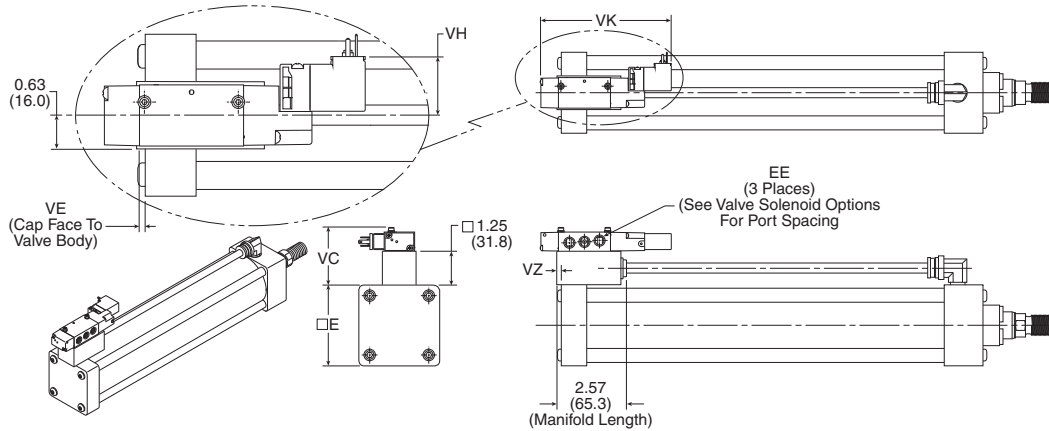

Full Manifold

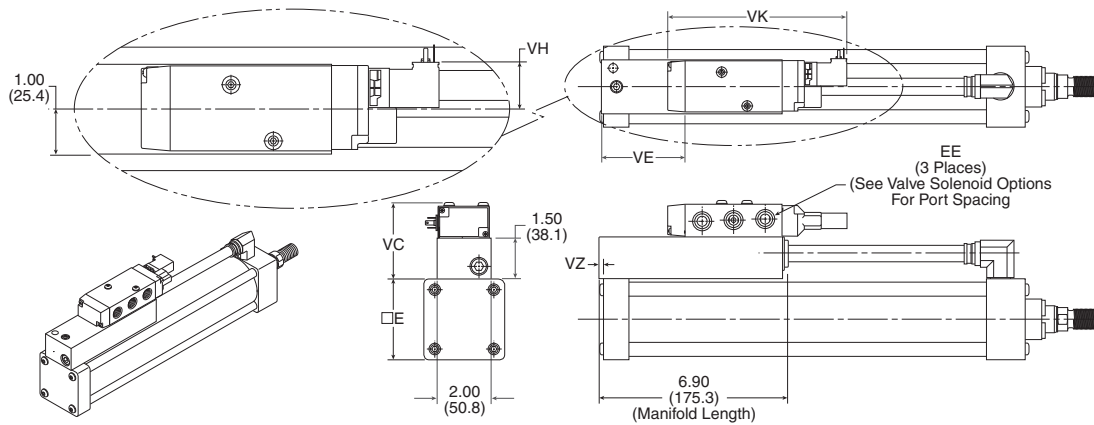

Dimensions

Bore	E (SQ.)	Manifold	Valve	VE*	VZ**	
1-1/2	2	Compact	B3	0.17 (4.3)	0.23 (5.8)	
			B3	3.78 (96.3)	0.23 (5.8)	
			B5	3.48 (88.4)	0.13 (3.3)	
		Full	B6	2.97 (75.4)	0.13 (3.3)	
			Compact	B3	0.17 (4.3)	0.23 (5.8)
				B3	3.78 (96.3)	0.13 (3.3)
B5	3.36 (85.3)	0.13 (3.3)				
2	2-1/2	Full	B6	2.97 (75.4)	0.13 (3.3)	
			Compact	B3	0.17 (4.3)	0.23 (5.8)
				B3	3.78 (96.3)	0.13 (3.3)
B5	3.36 (85.3)	0.13 (3.3)				
2-1/2	3	Full	B6	2.97 (75.4)	0.13 (3.3)	
			Compact	B3	0.17 (4.3)	0.23 (5.8)
				B3	3.78 (96.3)	0.13 (3.3)
B5	3.36 (85.3)	0.13 (3.3)				
3-1/4	3-3/4	Full	B6	2.97 (75.4)	0.13 (3.3)	
			Compact	B3	3.90 (99.1)	0.00
				B3	3.78 (96.3)	0.13 (3.3)
B5	3.48 (88.4)	0.00				
4	4-1/2	Full	B6	3.10 (78.7)	0.00	
			Compact	B3	3.90 (99.1)	0.00
				B3	3.78 (96.3)	0.13 (3.3)
B5	3.48 (88.4)	0.00				
5	5-1/2	Full	B6	3.10 (78.7)	0.00	
			Compact	B3	3.90 (99.1)	0.00
				B3	3.78 (96.3)	0.13 (3.3)
B5	3.48 (88.4)	0.00				

Valve	EE		VK	VC	
	(NPTF)	VH			
B3	1/8	1.09 (27.7)	4.67 (118.6)	Compact Manifold	2.12 (53.8)
				Full Manifold	2.37 (60.2)
B5	1/4	1.12 (28.4)	5.78 (146.8)	Full Manifold	2.81 (71.4)
B6	3/8	1.12 (28.4)	6.67 (169.4)	Full Manifold	2.81 (71.4)

* VE = Dimension from edge of endcap to edge of valve body.

** VZ = Dimension from edge of endcap to edge of manifold.

Note: Dimensions shown are for a single solenoid enclosure with Option 5. For other valve or enclosure option dimensions, see pages B68-B69.

B Tie Rod Pneumatic Cylinders

4MA Series

4MAJ Series

2MNR Series

ACVB Option

LPSO Option

P1D Series



For inventory, lead times, and kit lookup, visit www.pdnplu.com

Compact Manifold

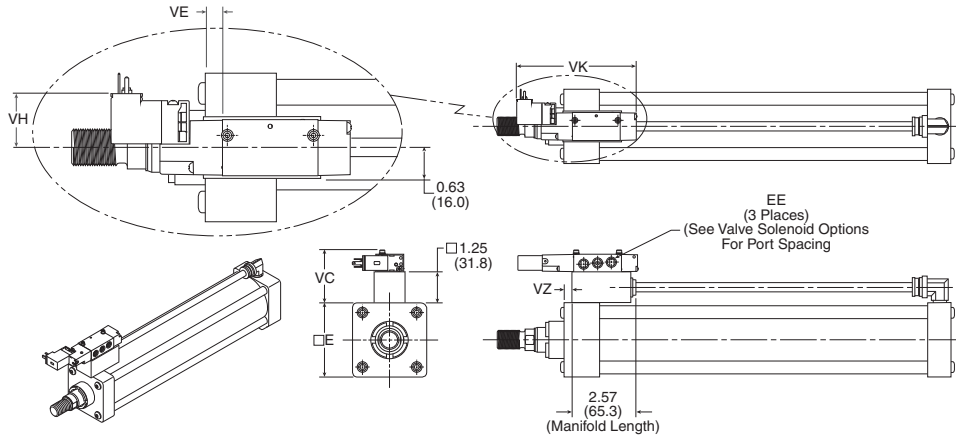

Full Manifold

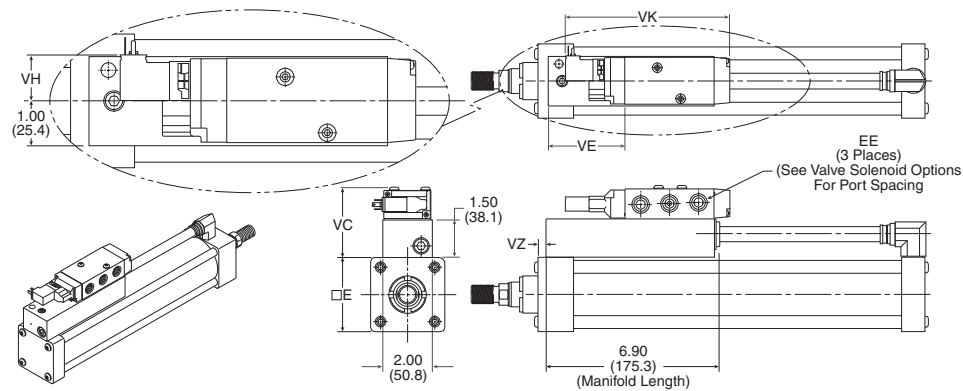

Dimensions

Bore	E (SQ.)	Manifold	Valve	VE*	VZ**
1-1/2	2	Compact	B3	0.26 (6.6)	0.20 (5.1)
			B3	4.21 (106.9)	0.31 (7.9)
			B5	3.79 (96.3)	0.31 (7.9)
		Full	B6	3.41 (86.6)	0.31 (7.9)
			B3	0.26 (6.6)	0.20 (5.1)
			B3	4.21 (106.9)	0.31 (7.9)
2	2-1/2	Full	B5	3.79 (96.3)	0.31 (7.9)
			B6	3.41 (86.6)	0.31 (7.9)
			B3	4.21 (106.9)	0.31 (7.9)
		Compact	B3	0.33 (8.4)	0.27 (6.9)
			B3	4.27 (108.5)	0.38 (9.6)
			B6	3.47 (88.1)	0.38 (9.6)
3-1/4	3-3/4	Full	B3	4.40 (111.8)	0.50 (12.7)
			B5	3.98 (101.1)	0.50 (12.7)
			B6	3.60 (91.4)	0.50 (12.7)
		Full	B3	4.40 (111.8)	0.50 (12.7)
			B5	3.98 (101.1)	0.50 (12.7)
			B6	3.60 (91.4)	0.50 (12.7)
4	4-1/2	Full	B3	4.40 (111.8)	0.50 (12.7)
			B5	3.98 (101.1)	0.50 (12.7)
			B6	3.60 (91.4)	0.50 (12.7)
		Full	B3	4.40 (111.8)	0.50 (12.7)
			B5	3.98 (101.1)	0.50 (12.7)
			B6	3.60 (91.4)	0.50 (12.7)

Valve	EE		VK	VC	
	(NPTF)	VH			
B3	1/8	1.09 (27.7)	4.67 (118.6)	Compact Manifold	2.12 (53.8)
					Full Manifold
B5	1/4	1.12 (28.4)	5.78 (146.8)	Full Manifold	2.81 (71.4)
	B6	3/8			1.12 (28.4)

* VE = Dimension from edge of endcap to edge of valve body.

** VZ = Dimension from edge of endcap to edge of manifold.

Note: single solenoid enclosure 5 shown. For other valve or options, see pages B68-B69.

B

Tie Rod Pneumatic Cylinders

4MA Series

4MAJ Series

2MNR Series

ACVB Option

LPSO Option

P1D Series



For inventory, lead time, and kit lookup, visit www.pdnplu.com

B67

Parker Hannifin Corporation
 Pneumatic Division
 Richland, Michigan
www.parker.com/pneumatics

Valve Solenoid Options

4MA ACVB

B3 Valve

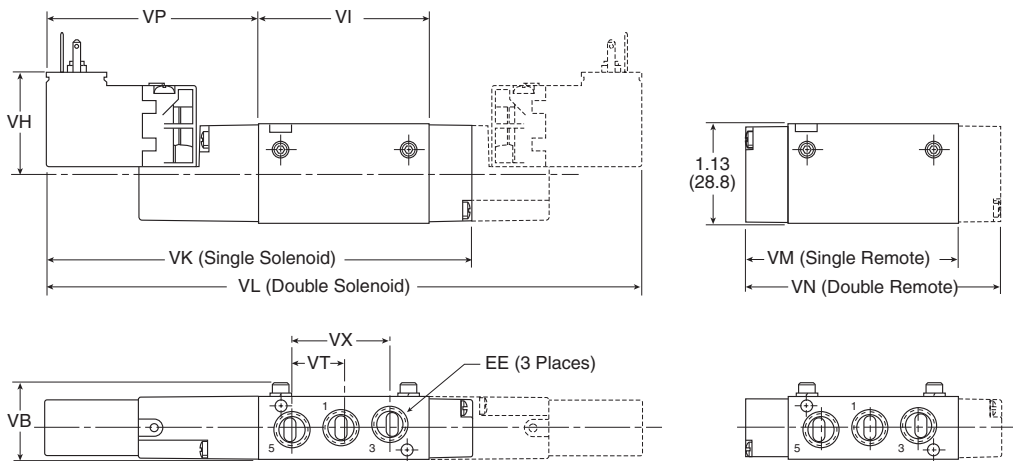

B5 and B6 Valve

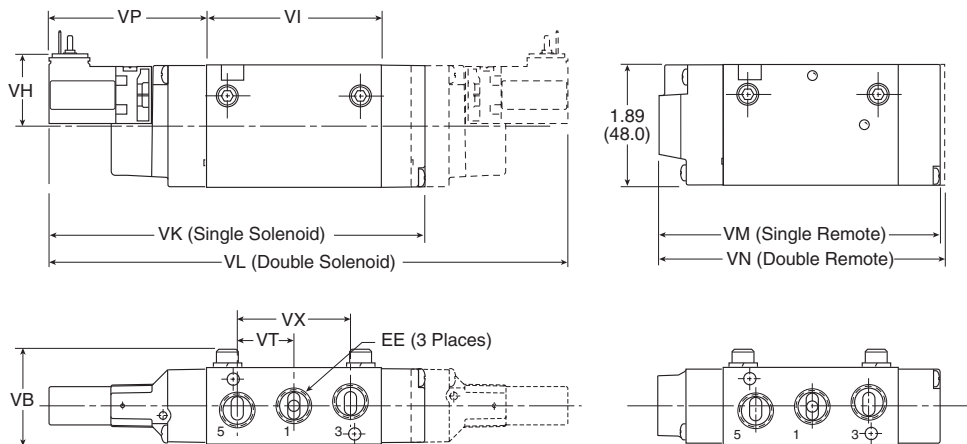

Valve Dimensions

Valve	EE (NPTF)	VB	VH	VI	VK	VL	VM	VN	VP	VT	VX
B3	1/8	0.87 (22.1)	1.09 (27.7)	1.93 (49.0)	4.67 (118.6)	6.44 (163.6)	3.12 (79.2)	3.33 (84.6)	2.25 (57.2)	0.56 (14.2)	1.12 (28.4)
B5	1/4	1.31 (33.3)	1.12 (28.4)	2.70 (68.6)	5.78 (146.8)	7.51 (190.8)	4.37 (111.0)	4.70 (119.4)	2.40 (61.0)	0.88 (22.4)	1.75 (44.5)
B6	3/8	1.31 (33.3)	1.12 (28.4)	3.60 (91.5)	6.67 (169.4)	8.41 (213.6)	5.26 (133.6)	5.59 (142.0)	2.40 (61.0)	1.17 (29.7)	2.34 (59.4)

B Tie Rod Pneumatic Cylinders

4MA Series

4MAJ Series

2MNR Series

ACVB Option

LPSO Option

P1D Series



For inventory, lead times, and kit lookup, visit www.pdnplu.com

B68

Parker Hannifin Corporation
 Pneumatic Division
 Richland, Michigan
www.parker.com/pneumatics

Optional Electrical Connections

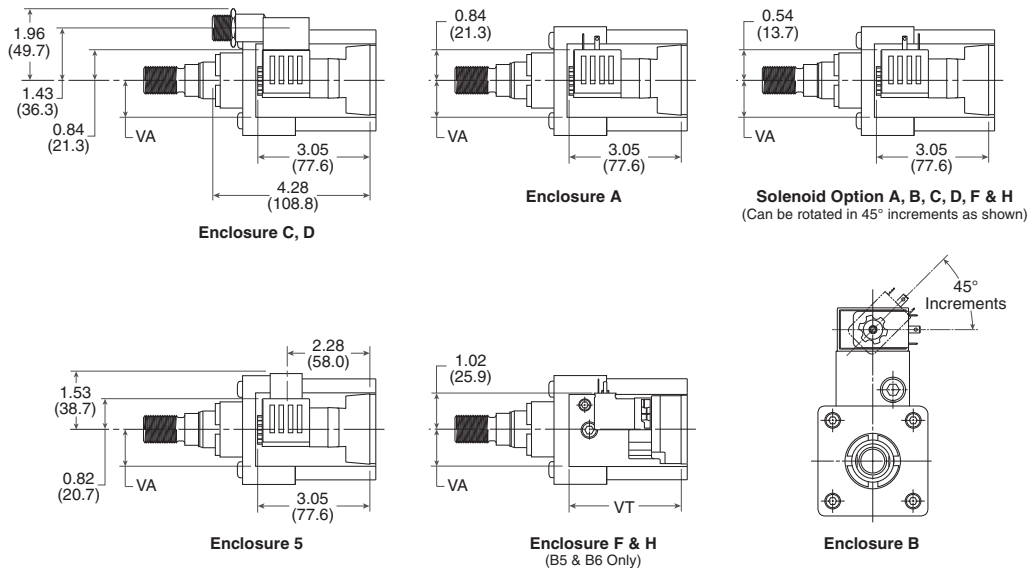

Optional Electrical Connections Dimensions

Valve	VA	VT
B3	0.63 (16.0)	2.25 (57.2)
B5	1.00 (25.4)	2.40 (61.0)
B6	1.00 (25.4)	2.40 (61.0)

Optional Flow Controls / Mufflers

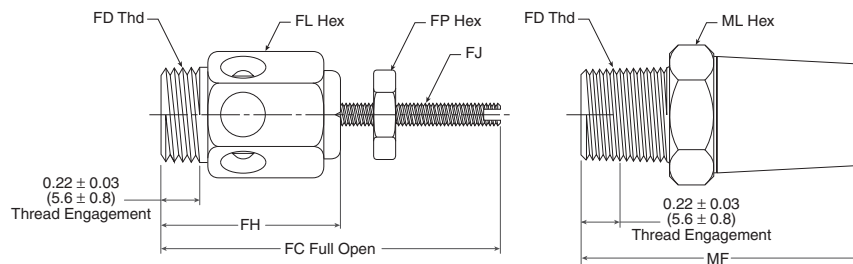

Optional Flow Controls / Mufflers Dimensions

Valve	FC	FD	FJ	FH	FL	FP	MF	ML
B3	1.48 (37.6)	1/8	10-32	0.90 (22.9)	1/2	3/8	1.00 (25.4)	7/16
B5	1.92 (48.8)	1/4	1/4-28	1.17 (29.7)	9/16	7/16	1.32 (33.5)	9/16
B6	1.92 (48.8)	3/8	1/4-28	1.27 (32.3)	11/16	7/16	1.54 (39.1)	11/16

B	Tie Rod Pneumatic Cylinders
	4MA Series
	4MAJ Series
	2MNR Series
	ACVB Option
	LPSO Option
	P1D Series



For inventory, lead time, and kit lookup, visit www.pdnplu.com

Manifold Kits Without Valve

	Compact manifold	Full manifold	
Bore Size	1-1/2", 2", and 2-1/2"	1-1/2", 2" and 2-1/2"	3-1/4", 4", and 5"
Kit w/ Tubing	L078350000	L078380000	L078390000
Kit w/o Tubing	L078370000	L078400000	L078410000
Max. Stroke for Kit w/ Tubing*	34.5"	39.5"	39"
Tubing Part #	0880383836	0880386336	

Example:

Manifold Kits:

Without Tubing Include:

- Manifold
- Grease
- O-rings for all applicable valves
- All necessary fasteners
- All necessary fittings
- Assembly Instructions

With Tubing Include:

- All "without tubing" items
- 36" of appropriate tubing
 - 3/8" O.D. for compact manifold
 - 5/8" O.D. for full manifold
- See above table for maximum stroke lengths.

Valve:

To Order Valve:

- Consult latest revision of Parker Pneumatic Products (Catalog #0600P).
- Specify "T" code as port size/thread type on B3, B5 or B6 valve order.
- All valves supplied with flush, locking overrides (code 'C').
- Manifolds designed for 2 position valves only.

Example: B61TBCH49A defines:

B6 ACVB Single Solenoid Valve, Flush Locking Override, with 1/2" NPT conduit, using 24VDC voltage.

Flow Controls & Mufflers:

Order as separate line items.

Valve size	Port size (NPTF)	Flow control part no.	Muffler part no.
B3	1/8	045020002	EM12
B5	1/4	045040004	EM25
B6	3/8	045060060	EM37

 **WARNING**

The Prestomatic fittings on the manifold and cylinder end caps are to be used in conjunction with Parker Air Brake tubing PFT-6B and PFT-10B only. The use of other tubing may not be compatible with the Prestomatic fittings. This may lead to a tubing failure which could cause the cylinder piston rod to suddenly retract or extend at high speed.

B
Tie Rod Pneumatic Cylinders

4MA Series

4MAJ Series

2MNR Series

ACVB Option

LPSO Option

P1D Series



For inventory, lead times, and kit lookup, visit www.pdnplu.com

Female Electrical Connectors

15mm 3-Pin DIN 43650C

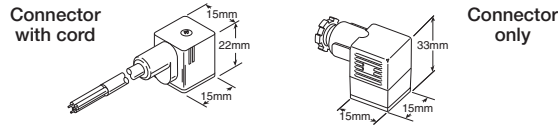

	Cord length	Connector	Connector with cord
Unlighted	6 Feet	PS2932BP	PS2932JBP
Light – 24VAC or DC	6 Feet	PS294679BP	PS2946J79BP*
Light – 110/120VAC	6 Feet	PS294683BP	PS2946J83BP*

* LED with surge suppression.

Note: Max ø6.5mm cable size required for connector w/o 6' (2m) cord. IP65 rated when properly installed.

Engineering data:

Conductors: 2 poles plus ground
Cable range (connector only): 4 to 6mm (0.16 to 0.24 Inch)
Contact spacing: 8mm

22mm Rectangular 3-Pin – Type B Industrial (Use with Enclosure “B”)

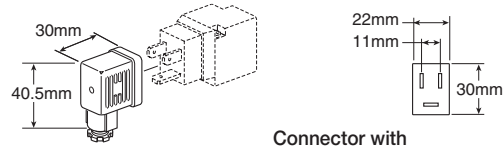

Description	Connector with 6' (2m) cord	Connector
Unlighted	PS2429JBP	PS2429BP
Light – 24V60Hz, 24VDC	PS2430J79BP*	PS243079BP
Light – 120V/60Hz	PS2430J83BP*	PS243083BP

* LED with surge suppression.

Note: Max ø6.5mm cable size required for connector w/o 6' (2m) cord. IP65 rated when properly installed.

Engineering data:

Conductors: 2 poles plus ground
Cable range (connector only): 6 to 8mm (0.24 to 0.31 Inch)
Contact spacing: 11mm

30mm Square 3-Pin – ISO 4400, DIN 43650A (Use with Enclosure “A”)

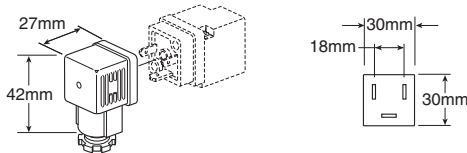

Description	Connector with 6' (2m) cord	Connector
Unlighted	PS2028JCP	PS2028BP
Light – 6-48V, 50/60Hz, 6-48VDC	PS2032J79CP*	PS203279BP
Light – 120V/60Hz	PS2032J83CP*	PS203283BP

* LED with surge suppression.

Note: Max ø6.5mm cable size required for connector w/o 6' (2m) cord. IP65 rated when properly installed.

Engineering data:

Conductors: 2 poles plus ground
Cable range (connector only): 8 to 10mm (0.31 to 0.39 Inch)
Contact spacing: 8mm

3-Pin / 5-Pin Male Automotive Connectors (Use on 22mm Rectangular 3-Pin Solenoid)

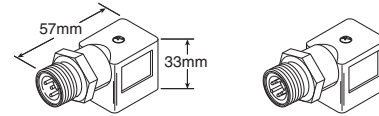

Description	3-pin	5-pin
Unlighted	PS2893CP	PS2893DP
Lighted - Voltage	PS2893C##P	PS2893D83P

– 79 = 24VDC & 24VAC
83 = 120VAC

B

Tie Rod Pneumatic Cylinders

4MA Series

4MAJ Series

2MNR Series

ACVB Option

LPSO Option

P1D Series

Linear Position Sensor Option

Linear Position Sensor for Continuous Position Feedback

B	Tie Rod Pneumatic Cylinders	4MA Series
		4MAJ Series
		2MNR Series
		ACVB Option
		LPSO Option
		P1D Series

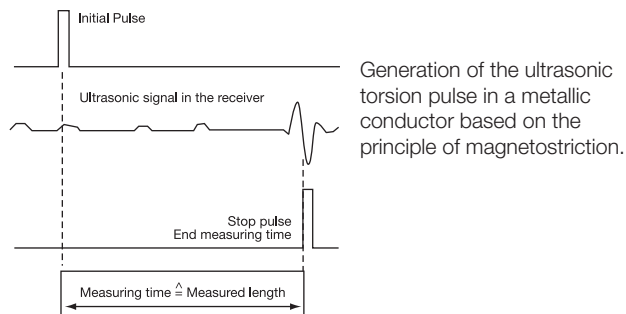

Generation of the ultrasonic torsion pulse in a metallic conductor based on the principle of magnetostriction.

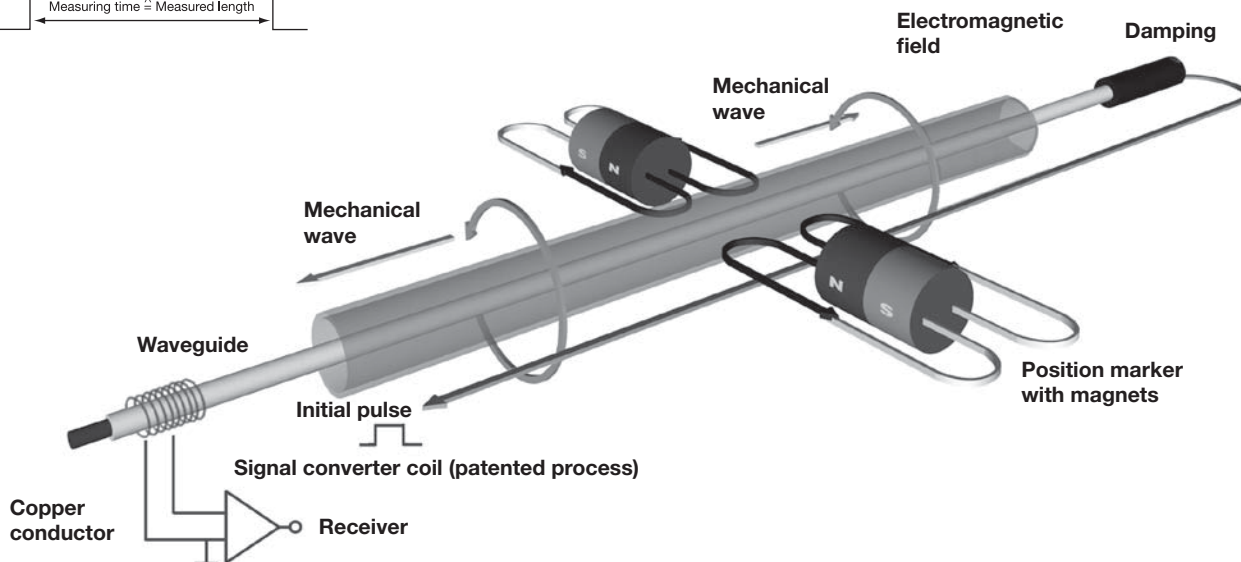
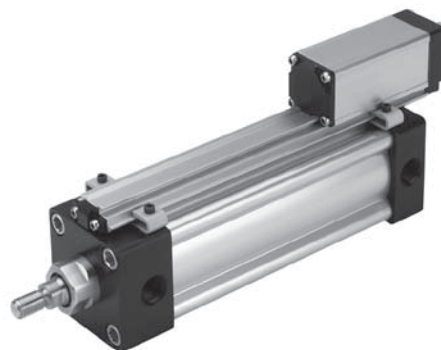

Principles of Operation

The measuring element ("waveguide"), consists of a special nickel-alloy tube.

A copper conductor is introduced through the length of this tube. The start of measurement is initiated by a short current pulse.

This current generates a circular magnetic field which rotates around the waveguide. A permanent magnet at the point of measurement is used as the marker element, whose lines of field run at right angles to the electromagnetic field. In the area on the waveguide where the two fields intersect, a magneto-strictive effect causes an elastic deformation of the waveguide, which propagates along the wave guide in both directions in the form of a mechanical wave.

The propagation velocity of this wave in the waveguide is 2830 m/s, and is nearly insensitive to environmental effects (e.g., temperature, shock, contamination).

The component of the wave which reaches the far end of the waveguide is damped there, whereas the component which arrives at the signal converter is changed into an electrical

signal by reversing the magnetostrictive effect. The wave travel time from its point of origin to the signal converter is directly proportional to the distance between the permanent magnet and the signal converter. A time measurement then allows the distance to be determined with extremely high accuracy.

Design

The transducers are made to the same safety and reliability standards for use in the harshest conditions:

- The electronics unit is compactly designed using SMD technology. The boards are protected in a space-saving, rugged aluminum extruded housing.
- The waveguide is protected in the extruded aluminum housing.

Quality

Each and every transducer undergoes a specially designed, computer-controlled testing procedure which includes 100% checking of all specified data.



For inventory, lead times, and kit lookup, visit www.pdnplu.com

Linear Position Sensor Option

The drawings below show that the Linear Position Sensor is longer than the cylinder of the same stroke length. The sensor overhang on the head end of the cylinder, as indicated by dimension A, may be eliminated by adding stop tubing, which effectively increases the gross stroke of the cylinder. The recommended stop tube lengths are provided in the table

Tie Rod Pneumatic Cylinders 4MA with LPSO

below for each bore size. The examples show that the electrical stroke of the sensor will always match the **net** stroke of the cylinder.

As a result of the limited sensing range of the sensor, it will overhang at the cap end of the cylinder by the amount of dimension B.

NO STOP TUBE

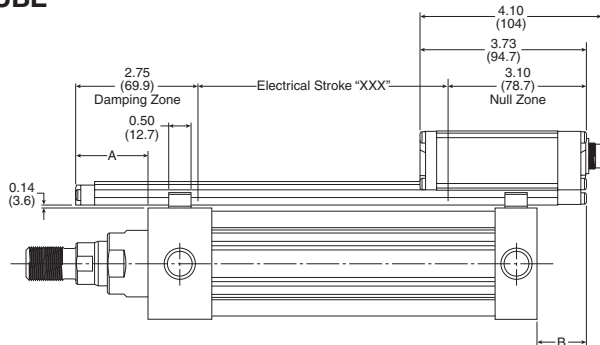

Example A: 12" Stroke cylinder without stop tube equals 12" Electrical Stroke for the Sensor.

WITH STOP TUBE

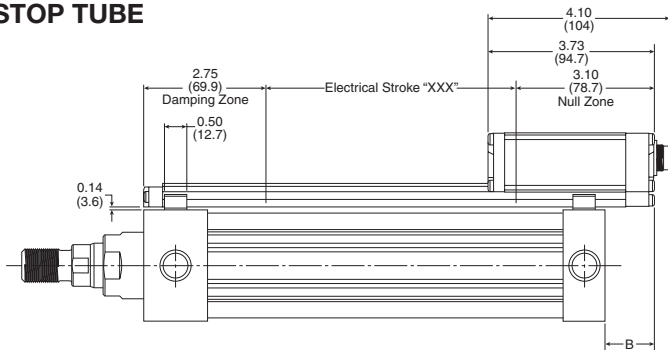

Example B: To eliminate sensor overhang on the head end of a 2.0" bore cylinder, add 1.0" of recommended stop tube length. The cylinder gross stroke becomes 13" and the net stroke remains 12". Specify a sensor with an electrical stroke of 12". Note that the electrical stroke equals cylinder **net** stroke length.

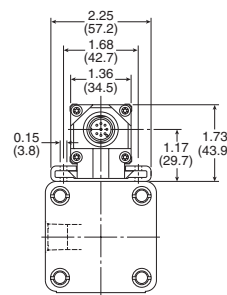

Example C: To eliminate sensor overhang on the head end of a 5.0" bore cylinder, add 0.625" of recommended stop tube length. The cylinder gross stroke becomes 12.625" and the net stroke remains 12". Specify a sensor with an electrical stroke of 12". Note that the electrical stroke equals cylinder **net** stroke length.

Bore	Rod code	Rod diameter	No stop tube		With stop tube		
			A	B	Stop tube length	A ₁	B
2	1	5/8	0.95	1.3	1.0	0	1.3
	3	1					
2-1/2	1	5/8	0.90	1.25	1.0	0	1.25
	3	1					
3-1/4	1	1	0.64	1.0	0.75	0	1.0
	3	1-3/8					
4	1	1	0.63	0.99	0.75	0	0.99
	3	1-3/8					
5	1	1	0.55	0.79	0.625	0	0.79
	3	1-3/8					
6	1	1-3/8	0.47	0.46	0.50	0	0.45
	3	1-3/4					
8	1	1-3/8	0.28	0.44	0.375	0	0.44
	3	1-3/4					

B

Tie Rod Pneumatic Cylinders

4MA Series

4MAJ Series

2MNR Series

ACVB Option

LPSO Option

P1D Series



For inventory, lead time, and kit lookup, visit www.pdnplu.com

Analog Interface Profile Series

**Tie Rod Pneumatic Cylinders
4MA with LPSO**

Output signal
Transducer interface
Input interface

analog
A
analog

analog
E
analog

B	Tie Rod Pneumatic Cylinders	
		4MA Series
		4MAJ Series
		2MNR Series
ACVB Option		
LPSO Option		
P1D Series		

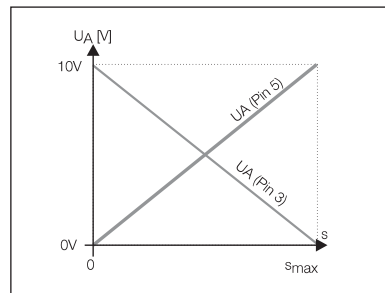

BTL5-A11-M-_-RSU022S32

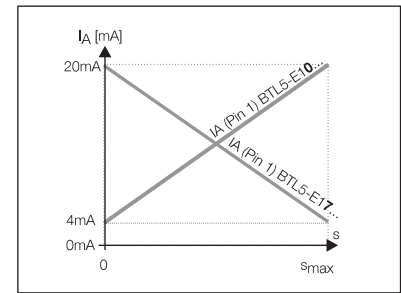

BTL5-E1-M-_-RSU022S32

Ordering code

Output voltage
Output current
Load current
Max. ripple
Load resistance
System resolution

0...10 V
max. 10 mA
≤ 5 mV
≤ 0.1 mV

4...20 mA
≤ 500 Ohm
≤ 0.2 μA

Hysteresis
Repeatability
Output update rate
Max. non-linearity

≤ 4 μm
6 μm (hysteresis + resolution)
STANDARD = 1 ms ¹400 mm
±100 μm to 500 mm stroke
±0.02 % 501...3606 mm stroke

Temperature coefficient Voltage output
Current output

[150 μV/°C + (5 ppm/°C x PxU/L)] x DT
[0.6 μA/°C + (10 ppm/°C x PxI/L)] x DT

Shock loading
Vibration
Traverse velocity of magnet

100 g/11 ms per IEC 68-2-27
12 g, 10...2000 Hz per IEC 68-2-6
any

Operating voltage
Current draw
Polarity reversal protected

24 V DC ± 20%
≤ 150 mA
yes

Overvoltage protection
Dielectric constant
Operating temperature
Storage temperature

Transzorb protection diodes
500 V (Ground to housing)
-40...185 °F (-40...85°C)
-40...212 °F (-40...100°C)

S32 Pin assignments	Pin	Color
Output signals	1	YE
	2	GY
	3	PK
	5	GN
Supply voltage	6	BU
	7	BN
	8	WH

BTL5-A11...
not used
signal GND
10...0 V
0...10 V
GND
+24 V DC
(GND)

BTL5-E1...BTL5-E7...
4...20 mA 20...4 mA
0 V output
10...0 V
0...10 V
GND
+24 V DC
(GND)

Connect shield to housing.

Specifications subject to change.

Please enter code for output signal and nominal stroke in ordering code.

BTL transducers with analog outputs are available in the ranges of 0...10V, 4...20mA with rising or falling signal.

Ordering Sample:

BTL5-A11-M-_-R-SU 022S32

Output signal
1 increasing and decreasing (for A)
0 increasing
7 decreasing (for E)

Standard stroke lengths (mm)



For inventory, lead times, and kit lookup, visit www.pdnplu.com

M Interface

Differential **START/STOP** control-specific interface.

P Interface

Compatible with BTA processors and various OEM controls. Reliable signal transmission, even over cable lengths up to 500 m (1640 ft.) between BTA and BTL, is assured by the especially noise-immune RS485 differential drivers and receivers. Noise signals are effectively suppressed.

Series
Transducer interface
User interface

BTL5 Low Profile
pulse M
pulse M

BTL5 Low Profile
pulse P
pulse P

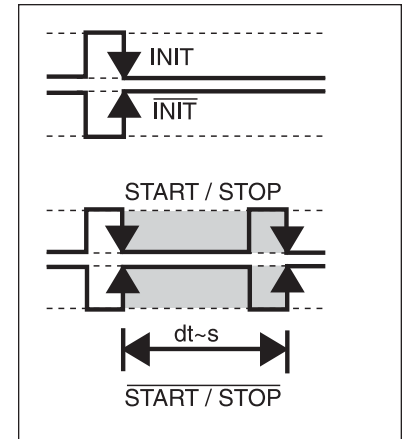
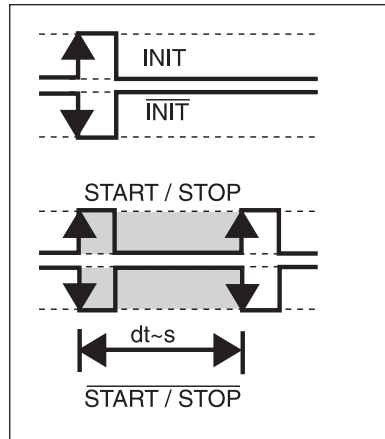

Ordering code
System resolution
Repeatability
Resolution
Hysteresis
Standard sampling rate
Max. non-linearity
Temperature coefficient of overall system
Traverse velocity of magnet
Operating voltage
Current draw
Operating temperature
Storage temperature

BTL5-**M**1-M___-RSU022S32

BTL5-**P**1-M___-RSU022S32

Process-dependent/control dependent
Hysteresis + Resolution
≤ 2 μm
≤ 4 μm
STANDARD = 1 kHz ≤1400 mm
±100 μm to 500 mm nominal stroke
±0.02 % 501...3750 mm nominal stroke
(6 μm + 5 ppm x L)/°C
any
24 V DC ±20 % or ±15V DC ±2% (optional)
≤ 100 mA
-40...185 °F (-40...85°C)
-40...212 °F (-40...100°C)

S32 Pin assignments	Pin	Color
Input/output signals	Input	1 YE
	Output	2 GY
	Input	3 PK
	Output	5 GN
Supply voltage	6	BU
	7	BN
	8	WH

BTL5- M 1-M...	BTL5- P 1-M...
INIT	INIT
START/STOP	START/STOP
INIT	INIT
START/STOP	START/STOP
GND	GND
+24 V DC	+24 V DC
(GND)	(GND)

Shield connected to housing

Specifications subject to change.

Please enter code for nominal stroke in ordering code.

Ordering Sample:

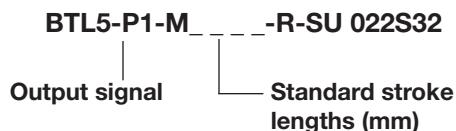

For inventory, lead time, and kit lookup, visit www.pdnplu.com

How To Order LPSO Option

Sensor Ordering Code

BTL-5 - A 1 1 - M 0305 - R SU022 S32

Output Signal	
A	0...10V
E	4...20mA
M	Differential Start/Stop, leading edge active
P	Differential Start/Stop, trailing edge active

Nominal Stroke	
Specify whole mm using 4 digits, i.e. 0305 = 305mm active electrical stroke*	
* Electrical stroke = net cylinder stroke.	

Connection Type	
S32	8-pin Quick Disconnect Metal Connector
KA05	Integral Axial Cable (specify cable length in whole meters using 2 digits, i.e. 05 = 5m)

Supply Voltage	
1	24 V ±20%

Housing Geometry	
R	Low Profile Extrusion

Output Signal (Analog only)	
1	Vmin or Vmax at Connector End, i.e. user selectable rising or falling*
0	Imin at Connector End (rising toward opposite end)**
7	Imax at Connector End (falling toward opposite end)**

* Available only with 0...10V output signal (A).
** Available only with 4...20mA output signal (E).

Please see page B3 or B19 to order 4MA cylinder configuration.

Standard Lengths

Electrical Stroke

inches	mm
2	0051
3	0077
4	0102
5	0127
6	0152
7	0178
8	0203
9	0230
10	0254
11	0280
12	0305
13	0330

inches	mm
15	0381
16	0407
18	0457
20	0508
22	0560
24	0610
26	0661
28	0711
30	0762
32	0813
36	0914
40	1016

inches	mm
42	1067
48	1220
50	1270
60	1524
70	1778
80	2032
90	2286
100	2540
110	2794
120	3048

S32 Cables

Length

5M	BKS-S32M-05
10M	BKS-S32M-10



For inventory, lead times, and kit lookup, visit www.pdnplu.com

Parker “Style 55” Piston Rod End

Rod end flange coupling for Parker 4MA, 4ML and 4MAJ Series cylinders:

- Simplifies alignment
- Reduces assembly time
- Allows full rated pneumatic pressure in push and pull directions
- Available in 5/8" through 1-3/4" piston rod diameters

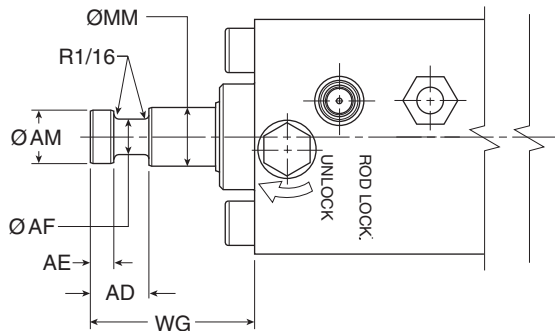

Example: Style 55 Rod End shown on 4MAJ Series cylinder

How To Order

Complete Model Number and place a “55” in the Piston Rod End designator position.

Example: 2.00 CJ4MAJU155C 6.000

Consult factory for availability of mounting accessories and hardware.

Style 55 Rod End Dimensions

Rod dia. MM	AD	AE	AF	AM	WG
5/8	5/8	1/4	3/8	.57	1-3/4
1	1-5/16	3/8	11/16	.95	2-3/8
1-3/8	1-1/16	3/8	7/8	1.32	2-3/4
1-3/4	1-5/16	1/2	1-1/8	1.70	3-1/8

See 4MA or 4MAJ Series sections for more dimensions.

Split Couplers and Weld Plates

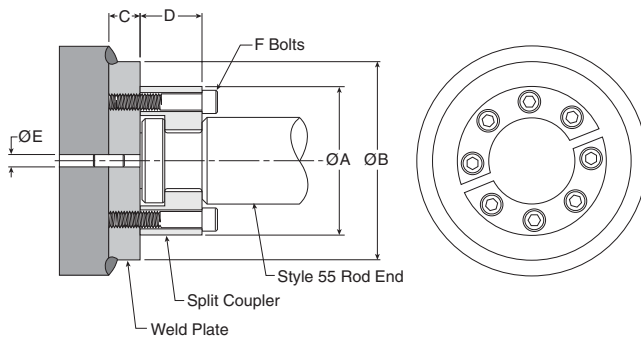

⚠ WARNING: Piston rod separation from the machine member can result in severe personal injury or even death to nearby personnel. The cylinder user must make sure the weld holding the weld plate to the machine is of sufficient quality and size to hold the intended load. The cylinder user must also make sure the bolts holding split coupler to the weld plate are of sufficient strength to hold the intended load and installed in such a way that they will not become loose during the machine's operation.

NOTE: Screws are not included with split coupler or weld plate.

Table 1
Part Numbers and Dimensions

Rod dia.	A	B	C	D	E	F	Bolt size	Bolt circle	Split coupler part no.	Weld plate part no.
0.625	1.50	2.00	0.50	0.56	0.250	4	#10-24 x .94 LG	1.125	1472340062	1481740062
1.00	2.00	2.50	0.50	0.88	0.250	6	.250-20 x 1.25 LG	1.500	1472340100	1481740100
1.375	2.50	3.00	0.63	1.00	0.250	6	.312-18 x 1.50 LG	2.000	1472340138	1481740138
1.75	3.00	4.00	0.63	1.25	0.250	8	.312-18 x 1.75 LG	2.375	1472340175	1481740175

NOTE: All dimensions without a tolerance are reference dimensions.

Metric Rod Threads

Standard metric thread sizes for piston rod thread type M.

Rod dia. MM	Styles 4 & 9 KK	Style 8 CC
3/8	M6 x 1.0	M8 x 1.25
1/2	M8 x 1.25	M12 x 1.25
5/8	M10 x 1.5	M12 x 1.5
1	M20 x 1.5	M22 x 1.5
1-3/8	M26 x 1.5	M30 x 2.0
1-3/4	M33 x 2.0	M39 x 2.0

NOTE: All other rod end dimensions are standard per catalog.

Check Seal Cushions

For Increased Productivity and Maximum Performance

The check seal cushion is new and different from ordinary cushion designs. It combines the sealing capabilities of a lipseal for efficient capture of air to effectively cushion and to provide check valve action for quick stroke reversal.

The design also provides “floating cushions” to assure cushion repeatability and long life. At the start of the stroke in each direction, the check valve design allows full flow to piston face with a minimum pressure drop for a maximum power stroke.

Additional benefits of the new check seal cushions are increased productivity and top performance for faster cycle time, minimum wear, easy adjustment and low pressure drop.

The basic cushion design is available at both ends without change in envelope or mounting dimensions. A captive cushion adjusting needle is supplied for easy, precise adjustment on all bore sizes.

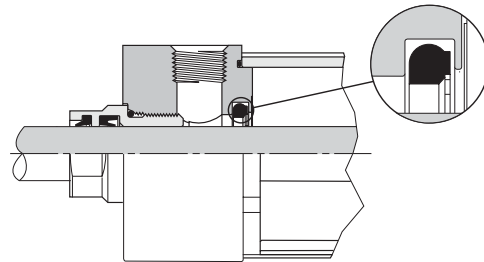

Bumpers

Impact dampening conventional bumpers can be provided on one or both sides of the piston with a 1/4" stroke loss per bumper. This style of bumper is ideal for applications subjected to high speeds where cycle time may discourage the use of cushions.

Available in 1-1/2" - 4" bore sizes for 4MA, 4ML and 4MAJ Series cylinders.

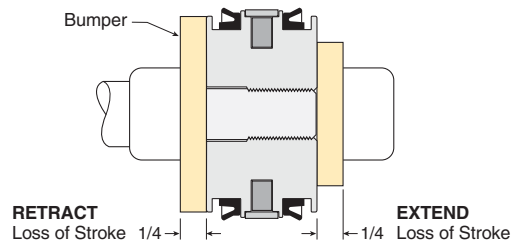

HI LOAD Gland Assembly

Applications with inherent side load require a slide package for maximum service life. In some cases, there may be limitations to the size or expense of these additional components. One possible solution may be the use of the optional HI LOAD gland assembly that incorporates a high strength composite bearing for radial load conditions. Extensive testing showed an approximate 50% increase in service life for general applications. Please note that each application is unique and results may vary. Includes seal options for standard, high and low temperature applications with air (4MA) or hydraulic (4ML) service.

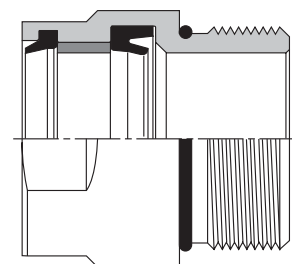

B
 Tie Rod Pneumatic
 Cylinders
 4MA
 Series
 4MAJ
 Series
 2MNR
 Series
 ACVB
 Option
 LPSO
 Option
 P1D
 Series



For inventory, lead times, and kit lookup, visit www.pdnplu.com

Bumper Seal Option

Impact dampening Bumper Seals are now optional on all 4MA and 4MAJ cylinders from 1-1/2" to 5" bore. The Bumper Seal piston combines the features of low-friction, rounded lipseals and impact-dampening bumpers to provide reduced noise and smoother end-of-stroke deceleration. At pressure greater than 80 PSI, the compressible Buna Nitrile or Fluorocarbon Bumper Seal has minimal effect on stroke loss. When specified, Bumper Seals will be supplied on both ends of the piston, eliminating the need to specify head end or cap end only.

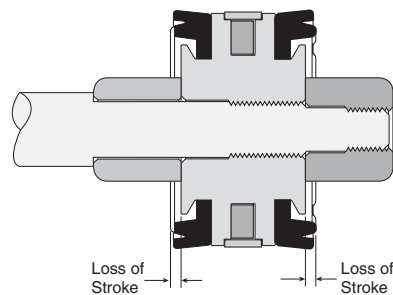

Summary of Accelerometer Test Results

Bore Size	Piston Type	Cushioning Efficiency (Maximum G's of Deceleration Force Created)	Cushioning Time (ms)
1-1/2"	Standard Piston	13.4	22
	Bumper Seal Piston	5.1	22
2"	Standard Piston	12.6	33
	Bumper Seal Piston	7.8	26
2-1/2"	Standard Piston	12.2	36
	Bumper Seal Piston	5.2	24

Bumper Seals Reduce Noise

The special profile of the Bumper Seal prevents the piston from noisily banging into the end cap at the end of stroke. Independent testing shows that the Bumper Seal, when combined with cushions, will absorb the final piston inertia and reduce the stroke noise by as much as 20 dB. The Sound Level Comparison graph illustrates the noise-reducing effects of the Bumper Seal piston when combined with cushions.

Impact noise was recorded at a distance of 3 feet from the front of the cylinder, inside a semi-anechoic chamber. Cylinders were operating at 95 PSI.

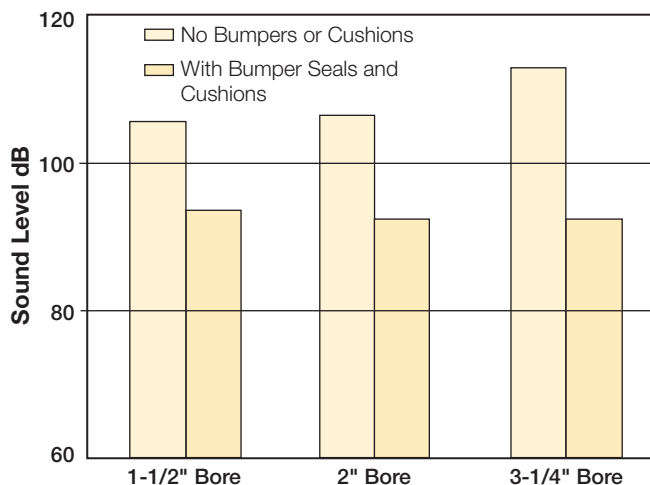

Sound Level Comparison

Bumper Seals have Minimum Effect on Stroke Length

The accompanying chart depicts typical amounts of overall stroke loss incurred at various system pressures. The amount of stroke loss may vary slightly due to design tolerances of seal size, variance in seal durometer and compression set associated with cylinder wear. To determine the stroke loss at either end of the cylinder, divide the values by two.

Pressure (PSI)	Typical Overall Loss of Stroke (inch) by Bore Size				
	1-1/2"	2"	2-1/2"	3-1/4"	4"
0	0.16	0.13	0.19	0.22	0.22
20	0.12	0.11	0.12	0.18	0.18
40	0.10	0.08	0.09	0.12	0.12
60	0.08	0.07	0.07	0.09	0.09
80	0.06	0.05	0.05	0.06	0.06
100	0.05	0.03	0.02	0.04	0.04

Accessories

1-1/2" to 8" Bore Cylinder Accessories

Rod end accessories can be selected by cylinder rod end thread size from Table A & B below. Mating parts for rod end accessories are listed just to the right of the knuckle or clevis selected. Mounting plates for style MP1 & MP4 cylinder mounts are selected by bore size from Table C.

Rod end thread size	TABLE A			TABLE B			TABLE C		
	Female rod clevis	Mating parts		Knuckle	Mating parts		Bore size	Mounting plates	
	Eye bracket	Pivot pin	Clevis bracket		Pivot pin	For mtg. style MP1 cylinder		For mtg. style MP4 cylinder	
7/16-20	1458030044	1458060050	0856640050	1458040044	1458050050	0856640050	1-1/2	1458060050	1458050050
1/2-20	1458030050	1458060050	0856640050	1458040050	1458050050	0856640050	2	1458060050	1458050050
3/4-16	1458030075	1458060075	0856640075	1458040075	1458050075	0856640075	2-1/2	1458060050	1458050050
7/8-14	1458030088	1458060100	0856640100	1458040088	1458050100	0856640100	3-1/4	1458060075	1458050075
1-14	1458030100	1458060100	0856640100	1458040100	1458050100	0856640100	4	1458060075	1458050075
1-1/4-12	1458030125	1458060138	0856640138	1458040125	1458050138	0856640138	5	1458060075	—
1-1/2-12	1458030150	1458060175	0856640175	1458040150	1458050175	0856640175	6	1458060100	—
							8	1458060100	—

Pivot Pin

Note: Pivot Pin must be ordered separately for single lug pivot mounting.

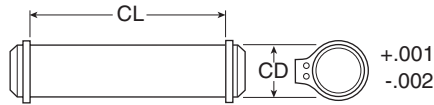

Note:

4MA Cylinder Mounting Kits and assembly instructions can be found on page B82. These kits can all be bolted onto cylinders with standard TEF mounts.

Symbol	0856640044	0683680000	0683690000	0683700000	0683710000	0683720000
CD	7/16	1/2	3/4	1	1-3/8	1-3/4
CL	1-5/16	1-7/8	2-5/8	3-1/8	4-1/8	5-3/16
Shear Cap. (lbs)	6600	8600	19300	34300	65000	105200

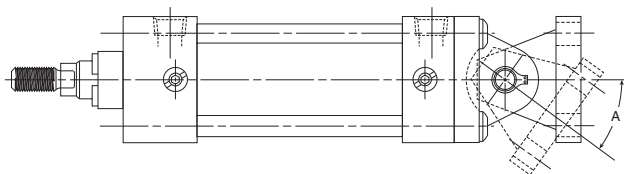

Maximum Pivot Angle for Rear Clevis Mounts (BB Mounts) and Accessories

Bore	1-1/2	2	2-1/2	3-1/4	4	5	6	8
Angle A	52	43	29	50	49	45	42	42



For inventory, lead times, and kit lookup, visit www.pdnplu.com

Female Rod Clevis

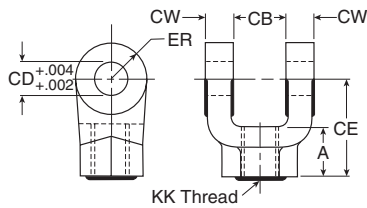

Symbol	1458030044	1458030050	1458030075	1458030088	1458030100	1458030125	1458030150
A	3/4	3/4	1-1/8	1-5/8	1-5/8	2	2-1/4
CB	3/4	3/4	1-1/4	1-1/2	1-1/2	2	2-1/2
CD	1/2	1/2	3/4	1	1	1-3/8	1-3/4
C E	1-1/2	1-1/2	2-1/8	2-15/16	2-15/16	3-3/4	4-1/2
CW	1/2	1/2	5/8	3/4	3/4	1	1-1/4
ER	1/2	1/2	3/4	1	1	1-3/8	1-3/4
KK	7/16-20	1/2-20	3/4-16	7/8-14	1-14	1-1/4-12	1-1/2-12
Load Capacity (lbs)	4250	4900	11200	18800	19500	33500	45600

Rod Eye Knuckle

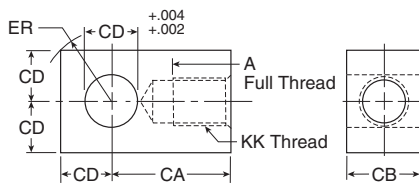

Symbol	1458040044	1458040050	1458040075	1458040088	1458040100	1458040125	1458040150
A	3/4	3/4	1-1/8	1-1/8	1-5/8	2	2-1/4
CA	1-1/2	1-1/2	2-1/16	2-3/8	2-13/16	3-7/16	4
CB	3/4	3/4	1-1/4	1-1/2	1-1/2	2	2-1/2
CD	1/2	1/2	3/4	1	1	1-3/8	1-3/4
ER	23/32	23/32	1-1/16	1-7/16	1-7/16	1-31/32	2-1/2
KK	7/16-20	1/2-20	3/4-16	7/8-14	1-14	1-1/4-12	1-1/2-12
Load Capacity (lbs)	5000	5700	12100	13000	21700	33500	45000

Clevis Bracket

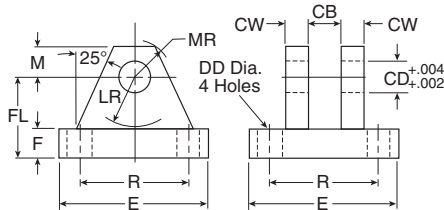

* Wall mount - will not mount directly to rear of cylinder.

Symbol	1458050044	1458050050	1458050075	1458050100	1458050138	1458050175
CB	15/32	3/4	1-1/4	1-1/2	2	2-1/2
CD	7/16	1/2	3/4	1	1-3/8	1-3/4
CW	3/8	1/2	5/8	3/4	1	1-1/4
DD	17/64	13/32	17/32	21/32	21/32	29/32
E	2-1/4	3-1/2	5	6-1/2	7-1/2	9-1/2
F	3/8	1/2	5/8	3/4	7/8	7/8
FL	1	1-1/2	1-7/8	2-1/4	3	3-5/8
LR	5/8	3/4	1-3/16	1-1/2	2	2-3/4
M	3/8	1/2	3/4	1	1-3/8	1-3/4
MR	1/2	5/8	29/32	1-1/4	1-21/32	2-7/32
R	1.75	2.55	3.82	4.95	5.73	7.50
Load Capacity (lbs)	3600	7300	14000	19200	36900	34000

Mounting Plate & Eye Bracket

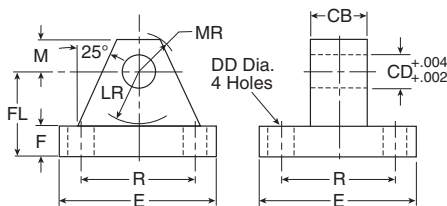

* Wall mount - will not mount directly to rear of cylinder.

Symbol	1458060031	1458060050	1458060075	1458060100	1458060138	1458060175
CB	15/16	3/4	1-1/4	1-1/2	2	2-1/2
CD	15/16	1/2	3/4	1	1-3/8	1-3/4
DD	17/64	13/32	17/32	21/32	21/32	29/32
E	2-1/4	2-1/2	3-1/2	4-1/2	5	6-1/2
F	3/8	3/8	5/8	7/8	7/8	1-1/8
FL	1	1-1/8	17/8	2-3/8	3	3-3/8
LR	5/8	3/4	1-1/4	1-1/2	2-1/8	2-1/4
M	3/8	1/2	3/4	1	1-3/8	1-3/4
MR	1/2	9/16	7/8	1-1/4	1-5/8	2-1/8
R	1.75	1.63	2.55	3.25	3.82	4.95
Load Capacity (lbs)	1700	4100	10500	20400	21200	49480



For inventory, lead time, and kit lookup, visit www.pdnplu.com

Mounting Kit Assembly

Perform the following steps when installing mounting kits onto 1-1/2" - 5" bore 4MA and 4ML cylinders with the standard mount (TE or TEF).

1. Clean mating parts to remove oil, grease and dirt.
2. Fasteners should be clean, dry and burr free.
3. Brush mounting fastener threads thoroughly with anti-seize lubricant.
4. Follow the appropriate procedure below for the desired mounting.

Rear Pivot Mounting Kits – Styles BB, BC and BE (Fig. 1)

Place pivot mount over end cap, lining up the four fastener holes in the end cap with the pivot mounting plate. Note that the pivot mount can be rotated allowing for different cylinder port locations. Secure mounting to cylinder cap (finger tight) using the four fasteners. Torque the fasteners to the specifications in the table below.

End Angle Mounting Kit – Styles CB (Fig. 2)

The end angles bolt to the front and rear of the cylinder end caps. The spacer plate** provided is to be assembled at the rod end under the angle plate. Line up the two holes of the spacer plate and angle plate with the two fastener holes in the cylinder head. If 2 different length fasteners are in the kit, use the longer fasteners for the cylinder head end (rod end) mount. Secure (finger tight) using two fasteners. Repeat this assembly at the opposite end (less spacer). Place the assembly with the end angles down on a flat surface and torque the four fasteners to the specifications shown in the table below.

Flange Mounting Kits – Styles J and H Single and Double Rod Cylinders (Fig. 3)

Place rectangular flange plate over appropriate end cap. Line up the four holes in the mounting plate with the four fastener holes in the cylinder end cap. Note that the rectangular mounting plate can be rotated to allow for different port locations. Secure the rectangular mounting plate to the end cap (finger tight) using the four fasteners. Then torque the four fasteners to the specifications shown in the table below.

Side End Lug Mounting Kits – Style G (Fig. 4)

Attach the two longer lugs with the fasteners provided in the kit to the cylinder head as shown. Attach the two shorter lugs to the cylinder cap in a similar fashion. Place the assembly with the lugs down on a flat surface and torque the four fasteners to the specifications shown in the table below.

Fig. 1 - Pivot Mounting Kit

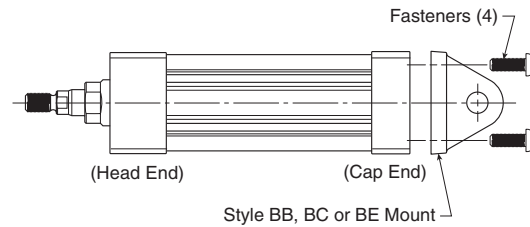

Fig. 2 - End Angle Mounting Kit

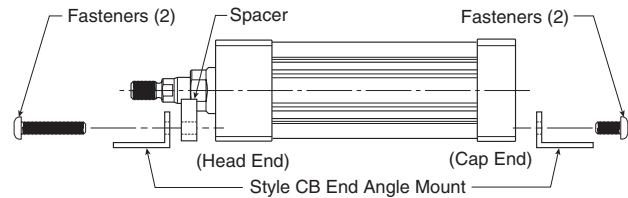

Fig. 3 - Flange Mounting Kit

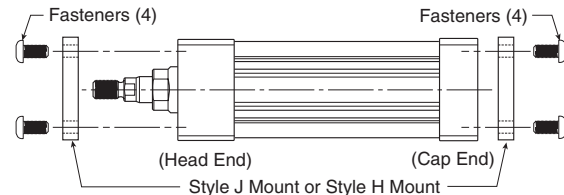
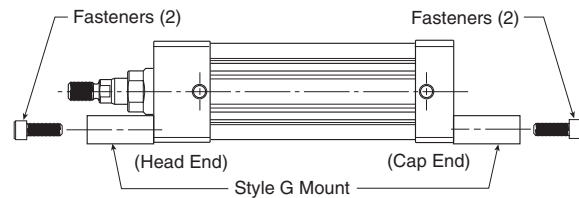

Fig. 4 - Side End Lug Mounting Kit - Style MS7



Mounting Kits

Bore Size	J (MF1)	H (MF2)	BB (MP1)	BC (MP2)	BE (MP4)	CB (MS1)	G (MS7)	Kit fastener torque units	
	Head rectangular flange	Cap rectangular flange	Cap fixed clevis	Cap detachable clevis	Cap detachable eye	Side end angles	Side end lug	USA	Metric
	Kit number	Kit number	Kit number	Kit number	Kit number	Kit number	Kit number	inch-lbs	Nm
1-1/2	L079700150	L079700150	L079710150	L079730150	L079720150	L079740150	L079750150	32 - 36	3.6 - 4.1
2	L079700200	L079700200	L079710200	L079730200	L079720200	L079740200	L079750200	72 - 82	8 - 9
2-1/2	L079700250	L079700250	L079710250	L079730250	L079720250	L079740250	L079750250	72 - 82	8 - 9
3-1/4	L079700325	L079700325	L079710325	L079730325	L079720325	L079740325	L079750325	216 - 228	24 - 25.3
4	L079700400	L079700400	L079710400	L079730400	L079720400	L079740400	L079750400	216 - 228	24 - 25.3
5	L079700500	L079700500	L079710500	L079730500	N/A	L079740500	N/A	360 - 372	41 - 42

** Spacer plate not used for 4" bore or double rod cylinders

P
 Tie Rod Pneumatic Cylinders
 4MA Series
 4MAJ Series
 2MNR Series
 ACVB Option
 LPSO Option
 P1D Series



For inventory, lead times, and kit lookup, visit www.pdnplu.com

Gland Kits (Gland cartridges and rod seals)

Pneumatic service only

Temperatures:

- Nitrile -10°F to 165°F (-23°C to 74°C)
- Fluorocarbon -10°F to 250°F (-23°C to 121°C)

Servicing the rod gland (Cylinder disassembly is not required)

Air leakage around the piston rod at the gland area will normally indicate a need to replace the gland cartridge.

The Parker 4MA gland is a unique cartridge design. It is threaded into the cylinder head and all sizes are removable without disturbing the endcap fasteners.

To remove the old gland cartridge from the cylinder:

1. Inspect the piston rod to be sure it is free of burrs or other foreign material that would prevent sliding the gland off the rod.
2. Disconnect any attachments to the piston rod end thread.
3. Lubricate the rod with Lube-A-Cyl (included in kit).
4. Unscrew the gland cartridge from the head using the appropriate wrench (see D1 dimension in catalog).
5. Slide the gland cartridge off the piston rod.
6. Verify that the gland-to-head o-ring (#45) is also removed from the head.

To install the new gland cartridge onto the cylinder:

1. Re-inspect the surface of the piston rod for scratches, dents and other surface damage, and repair if necessary.
2. Clean and lubricate the surface of the piston rod with Lube-A-Cyl (included in kit).
3. Lubricate the rod wiper (#40), rod seal (#41), o-ring (#45) and the inside surfaces of the gland cartridge with Lube-A-Cyl.
4. Slide the gland cartridge onto the piston rod, align it with the threads in the head, and tighten (clockwise) until seated firmly against the head.
5. Torque the gland cartridge to the specifications shown below. Tools are available to assist this process (see below).

Note: Make sure the gland cartridge is sufficiently tight. Failure to do so may result in loosening during operation.

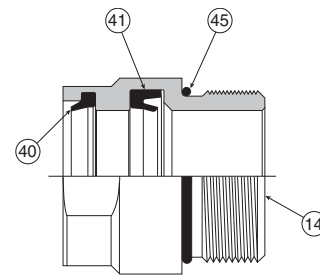

Standard Rod Gland

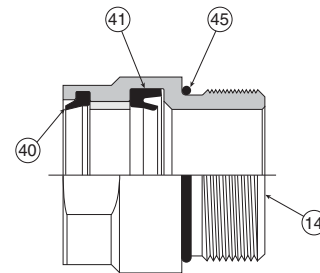

HI LOAD Rod Gland (includes composite bearing)

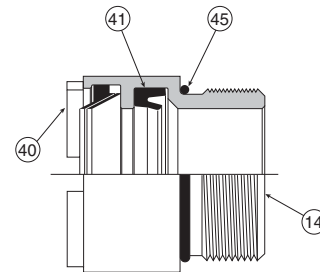

Metallic Rod Wiper Gland

Every gland cartridge kit contains 1 each of the following:

Symbol	Description
14	Gland
40	Rod Wiper
41	Rod Seal
45	O-ring - Gland to head

Rod dia.	Standard & HI LOAD gland		Metallic rod wiper gland	
	Gland wrench		Gland wrench	Spanner wrench
5/8	0695800000		0695900000	0116760000
1	0695810000		0695910000	0116760000
1-3/8	0695820000		0695920000	0117030000
1-3/4	0695830000		0695930000	0116770000

Bore size	Rod dia.	Rod no.	Standard rod gland cartridge kit includes 1 each of symbol 14, 40, 41 & 45		HI LOAD rod gland cartridge kit includes 1 each of symbol 14, 40, 41 & 45		Metallic rod wiper gland cartridge kit includes 1 each of symbol 14, 40, 41 & 45		Gland to head torque units	
			Nitrile seals kit number	Fluorocarbon seals kit number	Nitrile seals kit number	Fluorocarbon seals kit number	Nitrile & PUR seals kit number	Fluorocarbon seals kit number	USA ft-lbs	Metric N-m
1-1/2	5/8	1	RG04MA0061	RG04MA0065	RG04MAH061	RG04MAH065	RG04MAM061	RG04MAM065	40 - 45	54 - 61
		2	RG04MA0101	RG04MA0105	RG04MAH101	RG04MAH105	RG04MAM101	RG04MAM105	45 - 50	61 - 68
2	5/8	1	RG04MA0061	RG04MA0065	RG04MAH061	RG04MAH065	RG04MAM061	RG04MAM065	40 - 45	54 - 61
		3	RG04MA0101	RG04MA0105	RG04MAH101	RG04MAH105	RG04MAM101	RG04MAM105	45 - 50	61 - 68
2-1/2	5/8	1	RG04MA0061	RG04MA0065	RG04MAH061	RG04MAH065	RG04MAM061	RG04MAM065	40 - 45	54 - 61
		3	RG04MA0101	RG04MA0105	RG04MAH101	RG04MAH105	RG04MAM101	RG04MAM105	45 - 50	61 - 68
3-1/4	1-3/8	1	RG04MA0101	RG04MA0105	RG04MAH101	RG04MAH105	RG04MAM101	RG04MAM105	45 - 50	61 - 68
		3	RG04MA0131	RG04MA0135	RG04MAH131	RG04MAH135	RG04MAM131	RG04MAM135	75 - 80	102 - 108
4	1-3/8	1	RG04MA0101	RG04MA0105	RG04MAH101	RG04MAH105	RG04MAM101	RG04MAM105	45 - 50	61 - 68
		3	RG04MA0131	RG04MA0135	RG04MAH131	RG04MAH135	RG04MAM131	RG04MAM135	75 - 80	102 - 108
5	1-3/8	1	RG04MA0101	RG04MA0105	RG04MAH101	RG04MAH105	RG04MAM101	RG04MAM105	45 - 50	61 - 68
		3	RG04MA0131	RG04MA0135	RG04MAH131	RG04MAH135	RG04MAM131	RG04MAM135	75 - 80	102 - 108
6	1-3/8	1	RG04MA0131	RG04MA0135	RG04MAH131	RG04MAH135	RG04MAM131	RG04MAM135	75 - 80	102 - 108
		3	RG04MA0171	RG04MA0175	RG04MAH171	RG04MAH175	RG04MAM171	RG04MAM175	90 - 95	122 - 129
8	1-3/8	1	RG04MA0131	RG04MA0135	RG04MAH131	RG04MAH135	RG04MAM131	RG04MAM135	75 - 80	102 - 108
		3	RG04MA0171	RG04MA0175	RG04MAH171	RG04MAH175	RG04MAM171	RG04MAM175	90 - 95	122 - 129

B
Tie Rod Pneumatic Cylinders
4MA Series
4MAJ Series
2MNR Series
ACVB Option
LPSO Option
PID Series



For inventory, lead time, and kit lookup, visit www.pdnplu.com

Piston Seal Kits (Piston and cylinder body seals)

Pneumatic service only

Temperatures:

- Nitrile -10°F to 165°F (-23°C to 74°C)
- Fluorocarbon -10°F to 250°F (-23°C to 121°C)

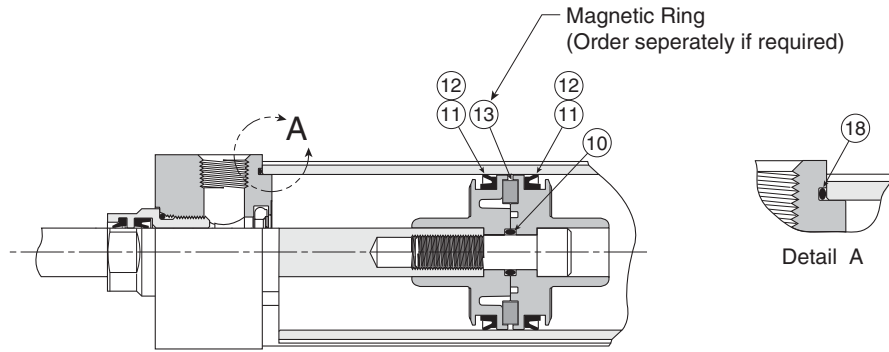
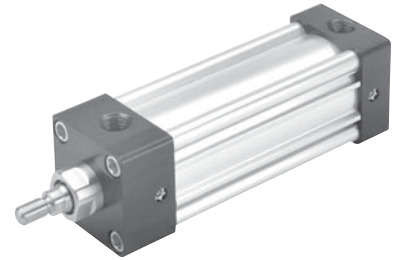

Composite piston assembly shown above.
Aluminum piston options available.
The same piston lipseals fit both piston types.

Servicing the piston seals – see next page

Warning – The piston rod (or fastener) to piston threaded connection is secured with an anaerobic adhesive that is temperature sensitive. Cylinders specified with all fluorocarbon seals are assembled with an anaerobic adhesive having a maximum operating temperature rating of 250°F (121°C). Cylinders specified with other seal compounds are assembled with an anaerobic adhesive having a maximum operating temperature rating of 165°F (74°C). These temperature limitations are necessary to prevent possible loosening of the threaded connections. Cylinders originally manufactured with Class 1 seals (Nitrile) that will be exposed to ambient temperatures above 165°F (74°C) must be modified for higher temperature service. Contact pdnapps@parker.com immediately and arrange for the piston to rod connection to be properly re-assembled to withstand the higher temperature service and other cylinder changes.

Note: the maximum temperature rating for the composite piston is 165°F (74°C).

Every standard piston seal kit (PK) contains 2 of the following:

Symbol	Description
11	Piston seal (lipseal)
18	O-ring - cylinder body to head & cap

Every bumper piston seal kit (BK) contains 2 of the following:

Symbol	Description
12	Piston seal (bumper seat cushion)
18	O-ring - cylinder body to head & cap

1 tube of Lube-A-Cyl is also included with each PK or BK kit.

Bore size	PK - Piston seal kit, standard lipseals includes 2 each of symbol 11 & 18 Includes wear band (#27) for aluminum pistons and 4" and 5" composite pistons		BK - Piston seal kit, bumper seals includes 2 each of symbol 12 & 18		Magnetic ring (not replaceable for composite piston) Only with nitrile seals part number	Torque units endcap fastener or tie rod	
	Nitrile seals kit number	Fluorocarbon seals kit number	Nitrile seals kit number	Fluorocarbon seals kit number		USA inch-lbs	Metric N-m
1-1/2	PK1504MA01	PK1504MA05	BK01504MA1	BK01504MA5	0865130151	32 - 36	3.6 - 4.1
2	PK2004MA01	PK2004MA05	BK02004MA1	BK02004MA5	0865130200	72 - 82	8 - 9
2-1/2	PK2504MA01	PK2504MA05	BK02504MA1	BK02504MA5	0865130250	72 - 82	8 - 9
3-1/4	PK3254MA01	PK3254MA05	BK03254MA1	BK03254MA5	0865130325	216 - 228	24 - 25.3
4	PK4004MA01	PK4004MA05	BK04004MA1	BK04004MA5	0865130400	216 - 228	24 - 25.3
5	PK5004MA01	PK5004MA05	BK05004MA1	BK05004MA5	0865130500	360 - 372	41 - 42
6	PK6004MA01	PK6004MA05	N/A	N/A	0865130600	420 - 432	48 - 49
8	PK8004MA01	PK8004MA05	N/A	N/A	0865130800	960 - 972	109 - 115



For inventory, lead times, and kit lookup, visit www.pdnplu.com

Parker Lube-A-Cyl...

Is recommended for use in air cylinders during normal operation, and particularly when servicing and reassembling cylinders. It is a multi-purpose lubricant in grease form that provides lubrication without deteriorating effects on synthetic seals. It produces a thin film which will not blow out with exhaust air. It provides piston, rod and seal lubrication, and has excellent resistance to water and mechanical breakdown with temperature range of -10°F to 350°F (-23°C to 177°C). Lube-A-Cyl is packaged in 1.5 oz. tubes, a sufficient quantity for average size air cylinder. One application should last for a period of 6 to 18 months depending upon service. Order by part number 0761630000.

Servicing the Piston Seals

Disassemble the cylinder completely, remove the old seals and clean all the parts. The cylinder bore and piston should then be examined for evidence of scoring. (The light scratch marks usually present on both cylinder bore and piston will generally have no detrimental effects on the performance of the cylinder.)

Apply Parker “Lube-A-Cyl” to O.D. of piston and all grooves. Install one piston Lipseal (sym. # 11 or 12) in the groove nearest the rod. The two “lips” of this seal should face toward the rod end of the piston. **Aluminum and 4" & 5" composite pistons only** – If required, install magnetic ring (sym. #13) in the bottom of the middle groove and then install wear band (sym. #27) in the top of the middle groove.

Coat the inside of the cylinder body with Parker “Lube-A-Cyl” and insert the piston – cap end first – into the cylinder body as shown in detail “2” below.

Next, turn the cylinder body on its side and push the piston and rod assembly through the barrel just far enough to expose the groove for the second Lipseal. (See detail “3” below.) For aluminum pistons, be careful not to move the piston too far so as to expose the wear strip (sym. #27). If the piston should move too far, push the piston and rod assembly completely through the cylinder body and again start the piston from the original end. Now install the second Lipseal (sym. # 11 or 12) in the exposed groove with the two “lips” facing away from the rod and pull the piston into the cylinder body.

The piston and rod are securely locked together with anaerobic adhesive. This threaded connection should only be disassembled or reassembled by factory trained personnel.

NOTE: An extreme pressure lubricant (such as molybdenum disulphate) should be used on the tie rod threads and bearing faces to reduce friction and tie rod twist.

Assemble both cap and head, complete with cylinder body O-Rings (sym. # 18), to each end of the cylinder body. Install end cap fasteners and tighten to appropriate torque, using opposite corner to corner torquing sequence.

In case of a “DD” – center trunnion – mounted cylinder, care must be taken to prevent binding the cylinder body when repositioning the trunnion collar. The proper method of assembling this type of cylinder is as follows:

After all the piston seals have been installed on the piston and the piston is in the cylinder body, fit the cap with its O-ring (sym. # 18) in position onto the cylinder body. Then “stud” into the trunnion collar the four tie rods that connect the cap to the trunnion collar. Hand tighten the four tie rod nuts at the cap. Distances from the inner face of the cap to the finished face of the trunnion collar should be made equal at all four tie rods when all four tie rod nuts are in contact with the cap.

When the assembly is ready for final torquing, it may be necessary to adjust the tie rods at the cap when torquing the tie rods at the head in order to position the trunnion collar in its final position.

As a check, to be certain the trunnion mount will not interfere with cylinder operation, move the piston and rod assembly by hand to determine whether there is any tendency for the piston to bind at the spot where the trunnion collar is located. If any binding is noticeable, readjust the tie rods.

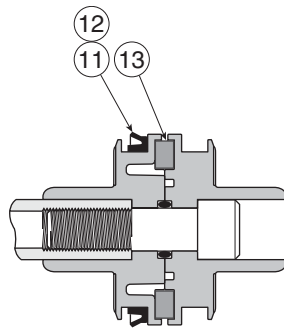

Detail “1”

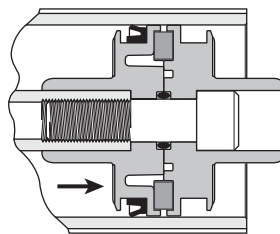

Detail “2”

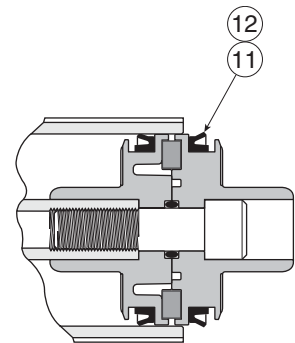

Detail “3”

B	Tie Rod Pneumatic Cylinders
	4MA Series
	4MAJ Series
	2MNR Series
	ACVB Option
	LPSO Option
	P1D Series



For inventory, lead time, and kit lookup, visit www.pdnplu.com

4MA Complete Cylinder Kits (All parts to service entire cylinder)

Pneumatic service only

Temperatures:

- Nitrile -10°F to 165°F (-23°C to 74°C)
- Fluorocarbon -10°F to 250°F (-23°C to 121°C)

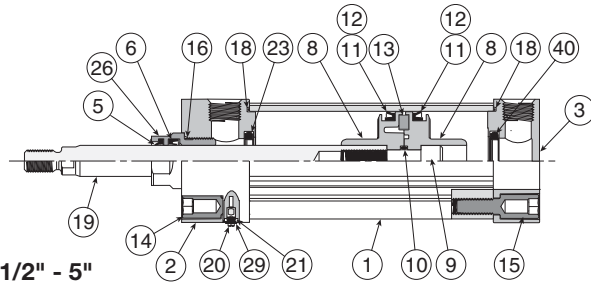
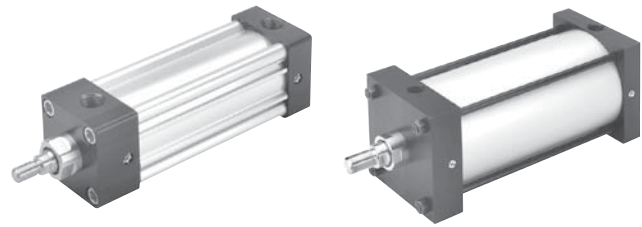

1-1/2" - 5" Bores

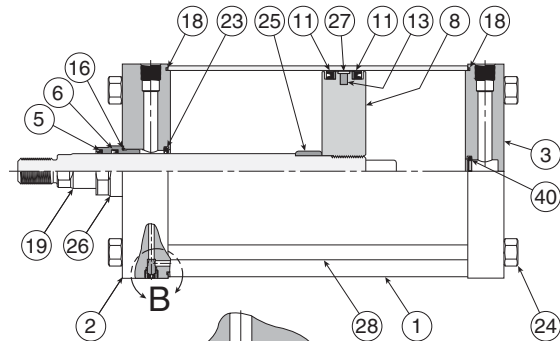

6" - 8" Bores

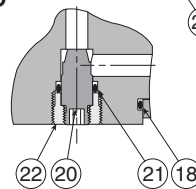

Detail B

Symbol	Description
1	Cylinder body
2	Head
3	Cap
5	Rod wiper
6	Rod seal
8	Piston (composite or aluminum)
9	Piston fastener (only for composite piston)
10	O-ring - piston fastener to piston
11	Piston seal (lipseal)
12	Piston seal (Bumper seal option)
13	Magnetic ring
14	Head fastener
15	Cap fastener
16	O-ring - gland to head
18	O-ring - cylinder body to head & cap
19	Piston rod
20	Cushion needle valve
21	O-ring - cushion needle valve
22	Cushion needle valve retainer (6" & 8")
23	Cushion check seal - head
24	Tie rod nut (6" & 8" bore or Style DD mounts)
25	Head cushion sleeve
26	Gland
27	Wear band (aluminum and 4" & 5" composite pistons)
28	Tie rod (6" & 8" bore or Style DD mounts)
29	Retaining washer
40	Cushion check seal - cap

Servicing the complete cylinder

This kit offers all parts to service an entire 4MA cylinder with the standard rod gland and standard piston lipseals. Kits are available with Nitrile or Fluorocarbon seals.

This kit is a combination of the Standard Gland Kit, Standard Piston Seal Kit, Head Cushion Kit and Cap Cushion Kit. The kits can service cylinders with either the composite or aluminum piston (lipseal). Depending on cylinder configuration, some parts may not be used. Please refer to the pages or bulletins of these individual kits for service instructions.

1 tube of Lube-A-Cyl is also included with each SK kit.

SK - Complete cylinder kit includes 1 each of standard rod gland kit, standard piston seal kit, head cushion kit and cap cushion kit

Bore size	Rod dia.	Rod no.	SK - Complete cylinder kit includes 1 each of standard rod gland kit, standard piston seal kit, head cushion kit and cap cushion kit		Gland to head torque units		Endcap fastener or tie rod torque units	
			Nitrile seals kit number	Fluorocarbon seals kit number	USA ft-lbs	Metric Nm	USA inch-lbs	Metric Nm
1-1/2	5/8	1	SK15104MA1	SK15104MA5	40 - 45	54 - 61	32 - 36	3.6 - 4.1
	1	2	SK15304MA1*	SK15304MA5*	45 - 50	61 - 68		
2	5/8	1	SK20104MA1	SK20104MA5	40 - 45	54 - 61	72 - 82	8 - 9
	1	3	SK20304MA1	SK20304MA5	45 - 50	61 - 68		
2-1/2	5/8	1	SK25104MA1	SK25104MA5	40 - 45	54 - 61	72 - 82	8 - 9
	1	3	SK25304MA1	SK25304MA5	45 - 50	61 - 68		
3-1/4	1	1	SK32104MA1	SK32104MA5	45 - 50	61 - 68	216 - 228	24 - 25.3
	1-3/8	3	SK32304MA1	SK32304MA5	75 - 80	102 - 108		
4	1	1	SK40104MA1	SK40104MA5	45 - 50	61 - 68	216 - 228	24 - 25.3
	1-3/8	3	SK40304MA1	SK40304MA5	75 - 80	102 - 108		
5	1	1	SK50104MA1	SK50104MA5	45 - 50	61 - 68	360 - 372	41 - 42
	1-3/8	3	SK50304MA1	SK50304MA5	75 - 80	102 - 108		
6	1-3/8	1	SK60104MA1	SK60104MA5	75 - 80	102 - 108	420 - 432	48 - 49
	1-3/4	3	SK60304MA1	SK60304MA5	90 - 95	122 - 129		
8	1-3/8	1	SK80104MA1	SK80104MA5	75 - 80	102 - 108	960 - 972	109 - 115
	1-3/4	3	SK80304MA1	SK80304MA5	90 - 95	122 - 129		

*Does not include Head Cushion Kit (not available)



For inventory, lead times, and kit lookup, visit www.pdnplu.com

4ML Gland Kits (Gland cartridges and rod seals)

Hydraulic service (includes TS-2000 rod seal)

Temperatures:

- Nitrile/Polyurethane (PUR) -10°F to 165°F (-23°C to 74°C)
- Fluorocarbon -10°F to 250°F (-23°C to 121°C)

Servicing the rod gland (Cylinder disassembly is not required)

Fluid leakage around the piston rod at the gland area will normally indicate a need to replace the gland cartridge.

The Parker 4ML gland is a unique cartridge design. It is threaded into the cylinder head and all sizes are removable without disturbing the endcap fasteners.

To remove the old gland cartridge from the cylinder:

1. Inspect the piston rod to be sure it is free of burrs or other foreign material that would prevent sliding the gland off the rod.
2. Disconnect any attachments to the piston rod end thread.
3. Lubricate the rod with clean light oil.
4. Unscrew the gland cartridge from the head using the appropriate wrench (see D1 dimension in catalog).
5. Slide the gland cartridge off the piston rod.
6. Verify that the gland-to-head o-ring (#45) is also removed from the head.

To install the new gland cartridge onto the cylinder:

1. Re-inspect the surface of the piston rod for scratches, dents and other surface damage, and repair if necessary.
2. Clean and lubricate the surface of the piston rod with clean light oil.
3. Lubricate the rod wiper (#40), rod seal (#41), o-ring (#45) and the inside surfaces of the gland cartridge with clean light oil.
4. Slide the gland cartridge onto the piston rod, align it with the threads in the head, and tighten (clockwise) until seated firmly against the head.
5. Torque the gland cartridge to the specifications shown below. Tools are available to assist this process (see below).

Note: Make sure the gland cartridge is sufficiently tight. Failure to do so may result in loosening during operation.

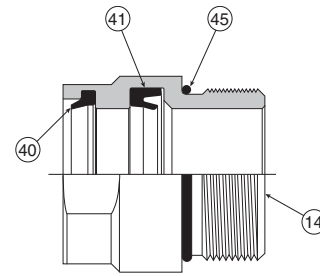

Standard Rod Gland

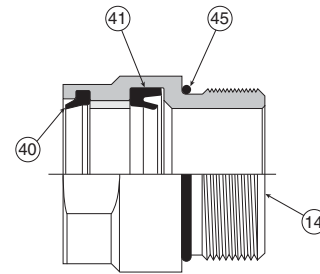

HI LOAD Rod Gland (includes composite bearing)

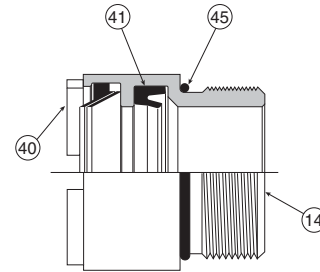

Metallic Rod Wiper Gland

Every gland cartridge kit contains 1 each of the following:

Symbol	Description
14	Gland
40	Rod Wiper
41	Rod Seal
45	O-ring - Gland to head

Rod dia.	Standard & HI LOAD gland		Metallic rod wiper gland	
	Gland wrench		Gland wrench	Spanner wrench
5/8	0695800000		0695900000	0116760000
1	0695810000		0695910000	0116760000
1-3/8	0695820000		0695920000	0117030000
1-3/4	0695830000		0695930000	0116770000

Bore Size	Rod Dia.	Rod No.	Standard rod gland cartridge kit includes 1 each of symbol 14, 40, 41 & 45		HI LOAD rod gland cartridge kit includes 1 each of symbol 14, 40, 41 & 45		Metallic rod wiper gland cartridge kit includes 1 each of symbol 14, 40, 41 & 45		Gland to head torque units	
			Nitrile & PUR seals kit number	Fluorocarbon seals kit number	Nitrile & PUR seals kit number	Fluorocarbon seals kit number	Nitrile & PUR seals kit number	Fluorocarbon seals kit number	USA ft-lbs	Metric N-m
1-1/2	5/8	1	RG04ML0061	RG04ML0065	RG04MLH061	RG04MLH065	RG04MLM061	RG04MLM065	40 - 45	54 - 61
	1	2	RG04ML0101	RG04ML0105	RG04MLH101	RG04MLH105	RG04MLM101	RG04MLM105	45 - 50	61 - 68
2	5/8	1	RG04ML0061	RG04ML0065	RG04MLH061	RG04MLH065	RG04MLM061	RG04MLM065	40 - 45	54 - 61
	1	3	RG04ML0101	RG04ML0105	RG04MLH101	RG04MLH105	RG04MLM101	RG04MLM105	45 - 50	61 - 68
2-1/2	5/8	1	RG04ML0061	RG04ML0065	RG04MLH061	RG04MLH065	RG04MLM061	RG04MLM065	40 - 45	54 - 61
	1	3	RG04ML0101	RG04ML0105	RG04MLH101	RG04MLH105	RG04MLM101	RG04MLM105	45 - 50	61 - 68
3-1/4	1	1	RG04ML0101	RG04ML0105	RG04MLH101	RG04MLH105	RG04MLM101	RG04MLM105	45 - 50	61 - 68
	1-3/8	3	RG04ML0131	RG04ML0135	RG04MLH131	RG04MLH135	RG04MLM131	RG04MLM135	75 - 80	102 - 108
4	1	1	RG04ML0101	RG04ML0105	RG04MLH101	RG04MLH105	RG04MLM101	RG04MLM105	45 - 50	61 - 68
	1-3/8	3	RG04ML0131	RG04ML0135	RG04MLH131	RG04MLH135	RG04MLM131	RG04MLM135	75 - 80	102 - 108
5	1	1	RG04ML0101	RG04ML0105	RG04MLH101	RG04MLH105	RG04MLM101	RG04MLM105	45 - 50	61 - 68
	1-3/8	3	RG04ML0131	RG04ML0135	RG04MLH131	RG04MLH135	RG04MLM131	RG04MLM135	75 - 80	102 - 108
6	1-3/8	1	RG04ML0131	RG04ML0135	RG04MLH131	RG04MLH135	RG04MLM131	RG04MLM135	75 - 80	102 - 108
	1-3/4	3	RG04ML0171	RG04ML0175	RG04MLH171	RG04MLH175	RG04MLM171	RG04MLM175	90 - 95	122 - 129
8	1-3/8	1	RG04ML0131	RG04ML0135	RG04MLH131	RG04MLH135	RG04MLM131	RG04MLM135	75 - 80	102 - 108
	1-3/4	3	RG04ML0171	RG04ML0175	RG04MLH171	RG04MLH175	RG04MLM171	RG04MLM175	90 - 95	122 - 129

B

Tie Rod Pneumatic Cylinders

4MA Series

4MAJ Series

2MNR Series

ACVB Option

LPSO Option

P1D Series



For inventory, lead time, and kit lookup, visit www.pdnplu.com

4ML Piston Seal Kits (Piston and cylinder body seals)

Hydraulic service

Temperatures:

- Nitrile -10°F to 165°F (-23°C to 74°C)
- Fluorocarbon -10°F to 250°F (-23°C to 121°C)

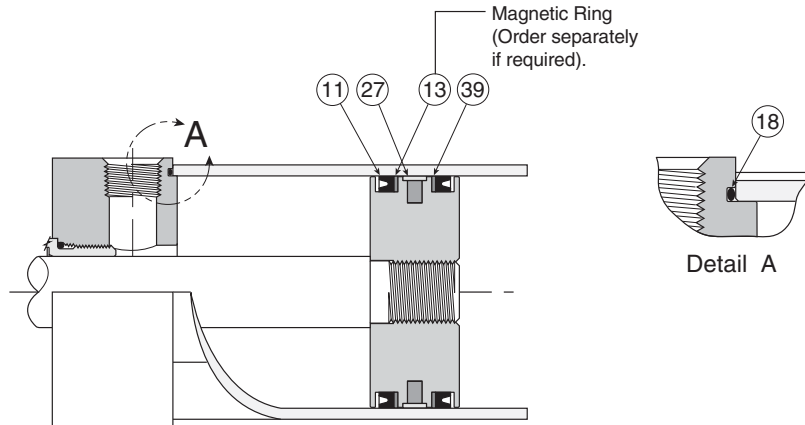
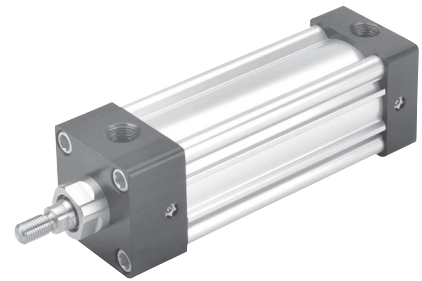

Servicing the piston seals – see next page

Warning – The piston rod (or fastener) to piston threaded connection is secured with an anaerobic adhesive that is temperature sensitive. Cylinders specified with all fluorocarbon seals are assembled with an anaerobic adhesive having a maximum operating temperature rating of 250°F (121°C). Cylinders specified with other seal compounds are assembled with an anaerobic adhesive having a maximum operating temperature rating of 165°F (74°C). These temperature limitations are necessary to prevent possible loosening of the threaded connections. Cylinders originally manufactured with Class 1 seals (Nitrile) that will be exposed to ambient temperatures above 165°F (74°C) must be modified for higher temperature service. Contact pdnapps@parker.com immediately and arrange for the piston to rod connection to be properly re-assembled to withstand the higher temperature service and other cylinder changes.

Every piston seal kit (PK) contains (2) of symbols 11, 18 and 39, and (1) of symbol 27

Symbol	Description
11	Piston seal (lipseal)
18	O-ring - cylinder body to head & cap
27	Wear band
39	Piston seal backup washer

PK - Piston Seal Kit, Standard Lipseals
Includes 2 each of symbol 11, 39 & 18
Wear band (#27) for aluminum piston included

Magnetic Ring
Symbol 13
Only with Nitrile Seals

Endcap Fastener or
Tie Rod Torque Units

Bore Size	Seals		Part Number	Torque Units	
	Nitrile Seals Kit Number	Fluorocarbon Seals Kit Number		USA inch-lbs	Metric N-m
1-1/2	PK1504ML01	PK1504ML05	0865130151	32 - 36	3.6 - 4.1
2	PK2004ML01	PK2004ML05	0865130200	72 - 82	8 - 9
2-1/2	PK2504ML01	PK2504ML05	0865130250	72 - 82	8 - 9
3-1/4	PK3254ML01	PK3254ML05	0865130325	216 - 228	24 - 25.3
4	PK4004ML01	PK4004ML05	0865130400	216 - 228	24 - 25.3
5	PK5004ML01	PK5004ML05	0865130500	360 - 372	41 - 42
6	PK6004ML01	PK6004ML05	0865130600	420 - 432	48 - 49
8	PK8004ML01	PK8004ML05	0865130800	960 - 972	109 - 115

B
 Tie Rod Pneumatic
 Cylinders
 4MA
 Series
 4MAJ
 Series
 2MNR
 Series
 ACVB
 Option
 LPSO
 Option
 P1D
 Series



For inventory, lead times, and kit lookup, visit www.pdnplu.com

Servicing the Piston Seals

Disassemble the cylinder completely, remove the old seals and clean all the parts. The cylinder bore and piston should then be examined for evidence of scoring. (The light scratch marks usually present on both cylinder bore and piston will generally have no detrimental effects on the performance of the cylinder.)

Apply clean light oil to O.D. of piston and all grooves. Install one piston Lipseal (sym. # 11) & one Back-Up Washer (sym. #39) in the groove nearest the rod. The two “lips” of the Lipseal (sym. #11) should face toward the rod end of the piston and the Back-Up Washer (sym. #39) should be installed in the same piston groove as shown. If required, install the magnetic ring (sym. # 13) in the bottom of the middle groove. (See detail “1” below) Next, install the wear strip (sym. # 27) in the top of the middle groove – (See detail “2” below).

Coat the inside of the cylinder body with clean light oil and insert the piston – cap end first – into the cylinder body as shown in detail “3” below.

Next, turn the cylinder body on its side and push the piston and rod assembly through the barrel just far enough to expose the piston groove for the second Lipseal. (See detail “4” below.) Be careful not to move the piston too far so as to expose the wear strip (sym. # 27). If the piston should move too far, push the piston and rod assembly completely through the cylinder body and again start the piston from the original end. Now install the second Lipseal (sym. # 11) & Back-Up Washer (sym. #39) in the exposed groove with the two “lips” of the Lipseal (sym. #11) facing away from the rod and the Back-Up Washer (sym. #39) positioned as shown. Then pull the piston into the cylinder body.

The piston and rod are securely locked together with anaerobic adhesive. This threaded connection should only be disassembled or reassembled by factory trained personnel.

NOTE: An extreme pressure lubricant (such as molybdenum disulphate) should be used on the tie rod threads and bearing faces to reduce friction and tie rod twist.

Assemble both cap and head, complete with cylinder body O-Rings (sym. # 18), to each end of the cylinder body. Install end cap fasteners and tighten to appropriate torque, using opposite corner to corner torquing sequence. After screws are torqued, firmly torque the rod gland against the head.

In case of a “DD” – center trunnion – mounted cylinder, care must be taken to prevent binding the cylinder body when repositioning the trunnion collar. The proper method of assembling this type of cylinder is as follows:

After all the piston seals have been installed on the piston and the piston is in the cylinder body, fit the cap with its O-ring (sym. # 18) in position onto the cylinder body. Then “stud” into the trunnion collar the four tie rods that connect the cap to the trunnion collar. Hand tighten the four tie rod nuts at the cap. Distances from the inner face of the cap to the finished face of the trunnion collar should be made equal at all four tie rods when all four tie rod nuts are in contact with the cap.

When the assembly is ready for final torquing, it may be necessary to adjust the tie rods at the cap when torquing the tie rods at the head in order to position the trunnion collar in its final position.

As a check, to be certain the trunnion mount will not interfere with cylinder operation, move the piston and rod assembly by hand to determine whether there is any tendency for the piston to bind at the spot where the trunnion collar is located. If any binding is noticeable, readjust the tie rods.

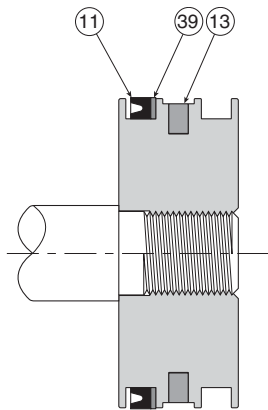

Detail “1”

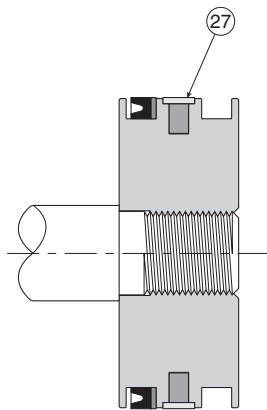

Detail “2”

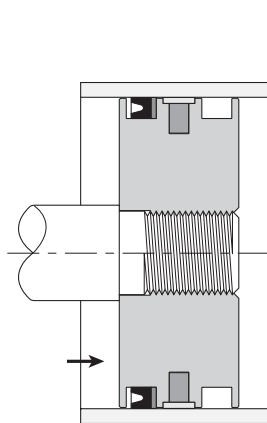

Detail “3”

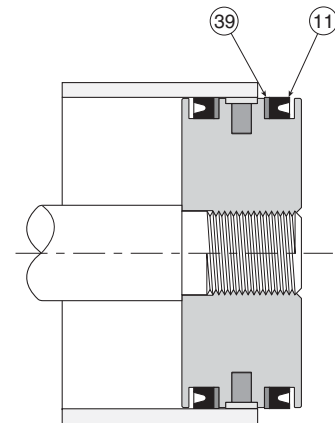

Detail “4”

B	Tie Rod Pneumatic Cylinders
	4MA Series
	4MAJ Series
	2MNR Series
	ACVB Option
	LPSO Option
	P1D Series

Cylinder Kits (All parts to service entire cylinder)

Hydraulic service

Temperatures:

- Nitrile/Polyurethane (PUR) -10°F to 165°F (-23°C to 74°C)
- Fluorocarbon -10°F to 250°F (-23°C to 121°C)

Servicing the complete cylinder

This kit offers all parts to service an entire 4ML cylinder with the standard rod gland and standard piston lipseals. Kits are available with Nitrile/Polyurethane or Fluorocarbon seals.

This kit is a combination of the Standard Gland Kit and Standard Piston Seal Kit. Please refer to the pages or bulletins of these individual kits for service instructions.

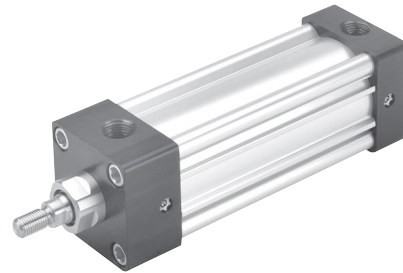

B
Tie Rod Pneumatic
Cylinders

Series
4MA
4MAJ
2MNR
ACVB
Option
LPSO
Option
P1D
Series

Bore size	Rod dia.	Rod no.	SK - Complete cylinder kit includes 1 each of standard rod Gland kit and piston seal kit		Gland to head torque units		Endcap Fastener or Tie Rod Torque Units	
			Nitrile & PUR seals kit number	Fluorocarbon seals kit number	USA ft-lbs	Metric Nm	USA inch-lbs	Metric Nm
1-1/2	5/8	1	SK15104ML1	SK15104ML5	40 - 45	54 - 61	32 - 36	3.6 - 4.1
	1	2	SK15304ML1	SK15304ML5	45 - 50	61 - 68		
2	5/8	1	SK20104ML1	SK20104ML5	40 - 45	54 - 61	72 - 82	8 - 9
	1	3	SK20304ML1	SK20304ML5	45 - 50	61 - 68		
2-1/2	5/8	1	SK25104ML1	SK25104ML5	40 - 45	54 - 61	72 - 82	8 - 9
	1	3	SK25304ML1	SK25304ML5	45 - 50	61 - 68		
3-1/4	1	1	SK32104ML1	SK32104ML5	45 - 50	61 - 68	216 - 228	24 - 25.3
	1-3/8	3	SK32304ML1	SK32304ML5	75 - 80	102 - 108		
4	1	1	SK40104ML1	SK40104ML5	45 - 50	61 - 68	216 - 228	24 - 25.3
	1-3/8	3	SK40304ML1	SK40304ML5	75 - 80	102 - 108		
5	1	1	SK50104ML1	SK50104ML5	45 - 50	61 - 68	360 - 372	41 - 42
	1-3/8	3	SK50304ML1	SK50304ML5	75 - 80	102 - 108		
6	1-3/8	1	SK60104ML1	SK60104ML5	75 - 80	102 - 108	420 - 432	48 - 49
	1-3/4	3	SK60304ML1	SK60304ML5	90 - 95	122 - 129		
8	1-3/8	1	SK80104ML1	SK80104ML5	75 - 80	102 - 108	960 - 972	109 - 115
	1-3/4	3	SK80304ML1	SK80304ML5	90 - 95	122 - 129		



For inventory, lead times, and kit lookup, visit www.pdnplu.com

Rod Lock Removal and Re-assembly

1-1/2" to 5" Bores

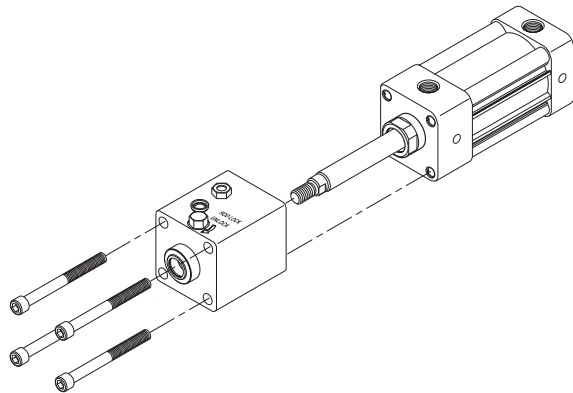

To **remove** the rod lock from the 4MAJ cylinder in order to service the base 4MAJ cylinder, please perform the following steps:

1. Remove the 4MAJ cylinder from the application to a serviceable area.
2. Using a corner-to-corner sequence, loosen the four SHCS fasteners (1-1/2" to 5" bores) or tie rod nuts (6" to 8" bores and all Style DD mounts (NFPA MT4) at the rod lock face and remove them from the rod lock. Please note that the tie rod nuts for 6" to 8" bores and all Style DD mounts are also used to assemble the base cylinder.
3. Apply a minimum of 60 PSI air pressure to the rod lock port, or apply the appropriate amount of torque to the manual override shaft, in order to release the rod lock from the piston rod.
4. Carefully slide the rod lock off the piston rod and away from the base cylinder. The rod lock is piloted and sealed to the gland OD, so some force may be required.
5. Particularly at larger bores, the rod lock can be heavy. Please remove the rod lock from the piston rod and follow all necessary safety precautions.

SHCS Fastener Torque or Tie Rod torque

Bore size	inch-lbs	Nm
1-1/2	32-36	3.6-4.1
2	72-82	8-9
2-1/2	72-82	8-9
3-1/4	216-228	24-25.3
4	216-228	24-25.3
5	360-372	41-42
6	420-432	48-49
8	960-972	109-115

6" to 8" Bores and all Style DD Mounts (NFPA MT4)

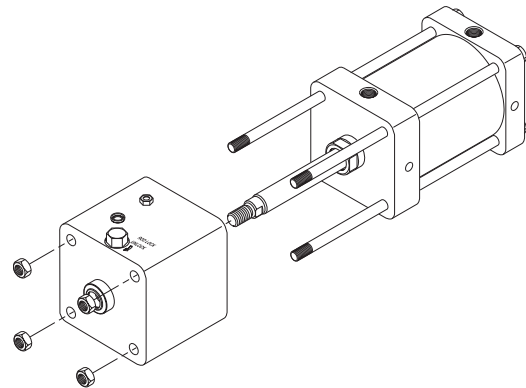

To **re-assemble** the rod lock to the base 4MAJ cylinder, please perform the following steps:

1. Remove all dirt and debris from the mating features of the rod lock, base cylinder, fasteners (or nuts) and threads.
2. Apply a minimum of 60 PSI air pressure to the rod lock port, or apply the appropriate amount of torque to the manual override shaft, in order to open the rod lock.
3. Carefully slide the rod lock onto the piston rod and toward the base cylinder. The rod lock is piloted and sealed to the gland OD, so some force may be required. Press the rod lock to the head face as close as possible, avoiding damage to the rod lock o-ring that seals the gland OD.
4. Using a corner-to-corner sequence, install and tighten, to approximately 75% of final torque specifications, the SHCS fasteners (1-1/2" to 5" bores) or tie rod nuts (6" to 8" bores and all Style DD mounts (NFPA MT4)) at the rod lock face. See torque specification table below.
5. Using a calibrated torque wrench, tighten the fasteners or nuts to the final torque specification using the same corner-to-corner sequence.
6. Remove the air pressure from the rod lock port or remove the torque from the manual override shaft to return the rod lock to the locked state.

The rod lock units are not field-repairable and must be returned to the Pneumatic Division for any repairs. Please contact pdnapps@parker.com for any assistance.

B

Tie Rod Pneumatic Cylinders

4MA Series

4MAJ Series

2MNR Series

ACVB Option

LPSO Option

P1D Series



For inventory, lead time, and kit lookup, visit www.pdnplu.com

Features

2MNR Series – 1-1/2" to 4" Bore Size

B	Tie Rod Pneumatic Cylinders
	Series
4MA Series	4MAJ Series
2MNR Series	ACVB Option
LPSO Option	P1D Series

MULTIPLE PISTON RODS

Three hard-chrome plated and polished piston rods provide stability and strength for higher bearing support. Precision machining provides precise fit for antirotation.

RETAINER

Retainer is easily removed for access to rod gland assemblies.

CHECK SEAL CUSHION

Molded urethane cushion combines the sealing capabilities of a lipseal for effective cushioning with check valve action for quick stroke reversal. "Floating" cushions assure cushion repeatability and long life.

ROUNDED LIP PISTON SEALS

Carboxylated nitrile w/PTFE seals glide over lubricant film instead of scraping it off.

TOOLING PLATE

Cold rolled carbon steel tooling plate with corrosion-resistant finish is easily removable for maintenance.

CUSHION NEEDLE VALVES

Adjustable captive design makes precise adjustment quick and easy. Can be adjusted while cylinder is under pressure.

CYLINDER BODY

Lightweight anodized aluminum body is wear resistant. The smooth extruded design eliminates areas for contamination.

PISTON AND WEAR BAND

Aluminum lightweight piston with nylon wear band (not shown) eliminates metal-to-metal contact to extend cylinder life. Formed, shaped wear band makes installation and repair easier than regular wear strip.

ROD SEAL/WIPER

Combination rod seal and rod wiper, available in either nitrile or fluorocarbon, is inserted into the bearing, creating a rod gland. Completely self-compensating for zero leakage at all pressures.

ROD BEARING

Permanently lubricated sintered bronze bearing provides excellent performance in nonlube applications. Bearings are easily removed for service.

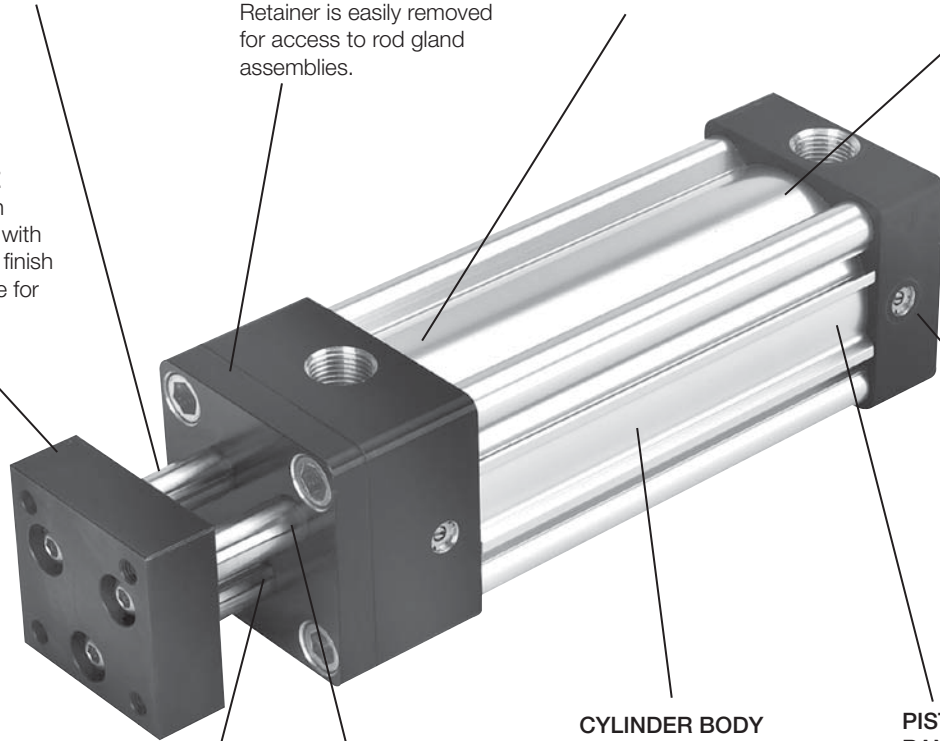

Mounting Styles

Tie Rod Pneumatic Cylinders

2MNR Series

2MNR Mounting Styles

Mounting style	NFPA mounting	Description	Bore size	Mounting style	NFPA mounting	Description	Bore size
T	MX0	Basic Mount	1-1/2 - 4	BC	MP2	Cap Detachable Clevis	1-1/2 - 4
TC	MX2	Tie Rod Extended Cap End	1-1/2 - 4	BB	MP1	Cap Fixed Clevis	1-1/2 - 4
TE	MX5	Sleeve Nut (Cap end only)	1-1/2 - 4	BE	MP4	Detachable Pivot Eye	1-1/2 - 4
F	MS4	Side Tap)	1-1/2 - 4	NB		Base Bar	1-1/2 - 4
J	MF1	Head Rectangular Flange	1-1/2 - 4	K		Double Rod	1-1/2 - 4
H	MF2	Cap Rectangular Flange	1-1/2 - 4				

B

Tie Rod Pneumatic Cylinders

4MA Series

4MAJ Series

2MNR Series

ACVB Option

LPSO Option

P1D Series



For inventory, lead times, and kit lookup, visit www.pdnplu.com

Air Cylinder Cushion Ratings

Bore size	Single ended cylinders and double ended cylinders – multi-rod both ends			Double ended cylinders – single rod one end		
	Cylinder end	Rating with no back pressure	Rating with back pressure	Cylinder end	Rating with no back pressure	Rating with back pressure
1-1/2"	Cap	12	17	Single Rod	7	12
	Rod	6	11	Triple Rod	6	11
2"	Cap	14	20	Single Rod	11	16
	Rod	10	14	Triple Rod	10	14
2-1/2"	Cap	17	23	Single Rod	12	18
	Rod	11	15	Triple Rod	11	15
3-1/4"	Cap	21	26	Single Rod	15	20
	Rod	15	20	Triple Rod	15	20
4"	Cap	23	28	Single Rod	17	23
	Rod	17	23	Triple Rod	17	23

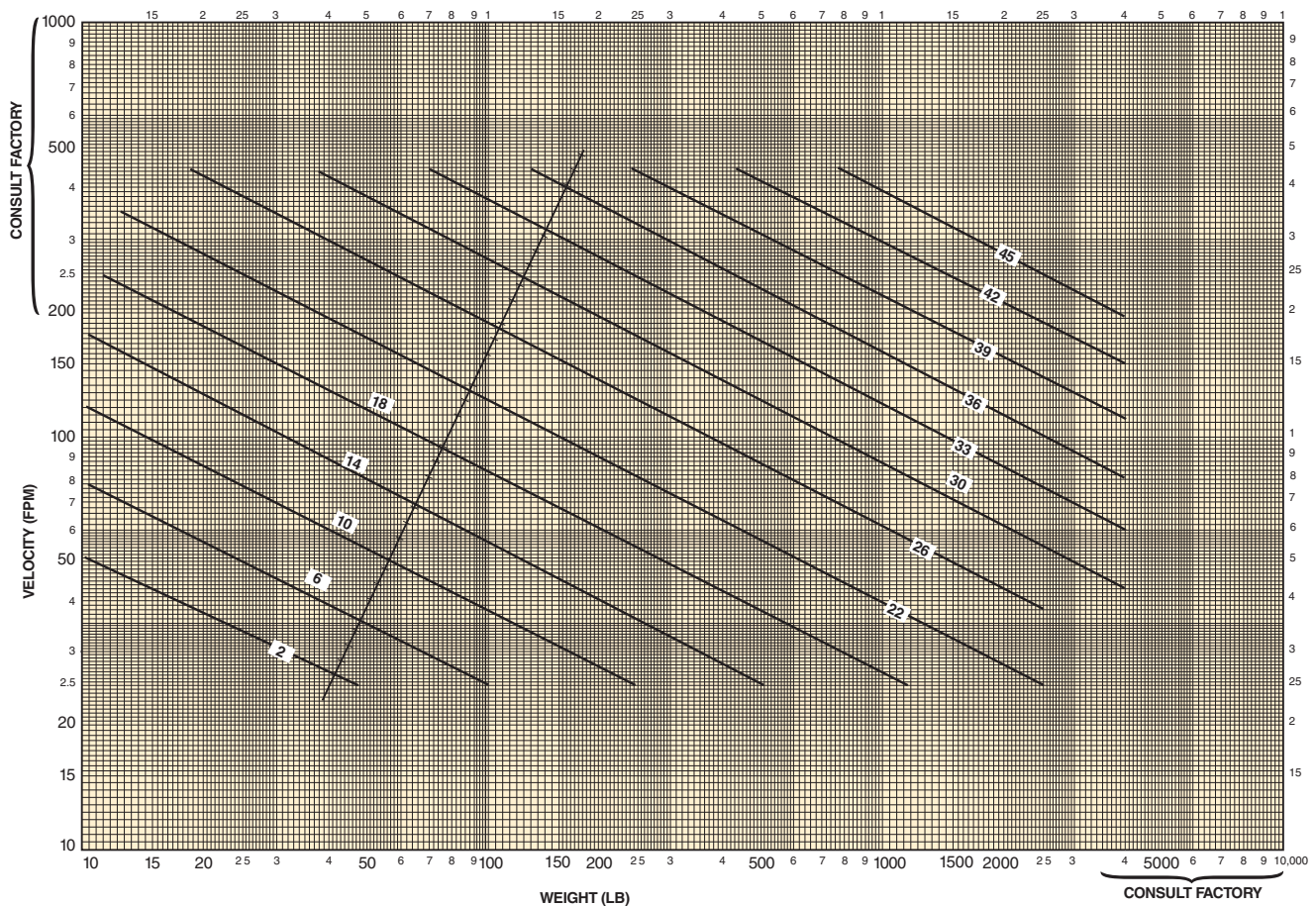

B

Tie Rod Pneumatic Cylinders

4MA Series

4MAJ Series

2MNR Series

ACVB Option

LPSO Option

P1D Series



For inventory, lead time, and kit lookup, visit www.pdnplu.com

B95

Parker Hannifin Corporation
 Pneumatic Division
 Richland, Michigan
www.parker.com/pneumatics

Loading Information

Side Load Versus Stroke

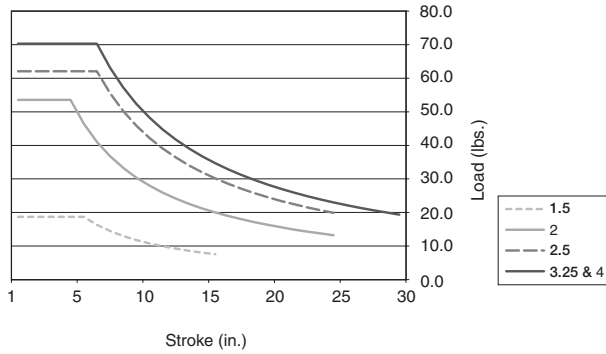

Side Load

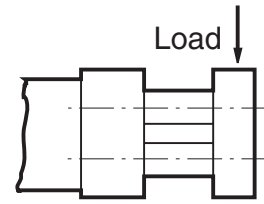

Torsional Load

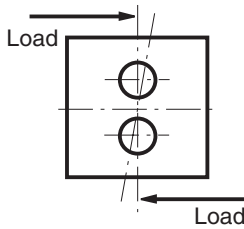

Torsional Load Versus Stroke

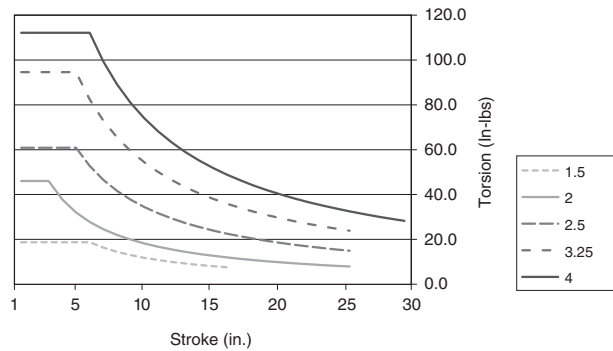

Theoretical Extend and Retract Forces in Pounds

Bore Size	Movement	Effective area (in ²)	Pressure (PSI)								Cu. ft. of displacement per inch of stroke
			20	40	60	80	100	150	200	250	
1-1/2"	Extend	1.767	35	71	106	141	177	265	353	442	0.00102
	Retract	1.537	31	61	92	123	154	231	307	384	0.00089
2"	Extend	3.142	63	126	188	251	314	471	628	785	0.00182
	Retract	2.553	51	102	153	204	255	383	511	638	0.00148
2-1/2"	Extend	4.909	98	196	295	393	491	736	982	1227	0.00284
	Retract	3.988	80	160	239	319	399	598	798	997	0.00231
3-1/4"	Extend	8.296	166	332	498	664	830	1244	1659	2074	0.00480
	Retract	7.375	148	295	443	590	738	1106	1475	1844	0.00427
4"	Extend	12.566	251	503	754	1005	1257	1885	2513	3142	0.00727
	Retract	11.646	233	466	699	932	1165	1747	2329	2911	0.00674

Double Rod Extend Forces – Single Rod Style

Bore Size	Rod Size	Effective area (in ²)	Pressure (PSI)								Cu. ft. of displacement per inch of stroke
			20	40	60	80	100	150	200	250	
1-1/2"	5/8"	1.460	29	58	88	117	146	219	292	365	0.00085
2"	5/8"	2.835	57	113	170	227	283	425	567	709	0.00164
2-1/2"	5/8"	4.602	92	184	276	368	460	690	920	1150	0.00266
3-1/4"	1"	7.510	150	300	451	601	751	1127	1502	1878	0.00435
4"	1"	11.781	236	471	707	942	1178	1767	2356	2945	0.00682



For inventory, lead times, and kit lookup, visit www.pdnplu.com

B Tie Rod Pneumatic Cylinders
 4MA Series
 4MAJ Series
 2MNR Series
 ACVB Option
 LPSO Option
 P1D Series

Dimensional Data

Basic Single End – Style T (NFPA MX0)

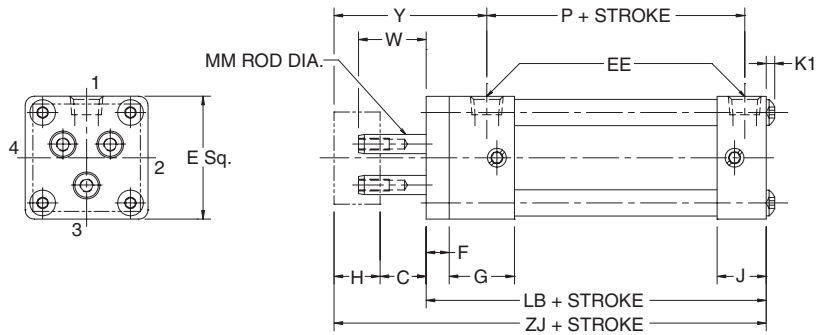
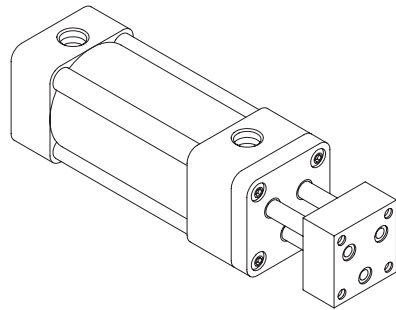

Style T and Dimensions

Bore	Rod dia. mm	C	E	EE (NPTF)	F	G	H	J	K1	W	Y	Add stroke		
												LB	P	ZJ
1-1/2	8mm	3/4	2	1/4	3/8	1-7/16	3/4	15/16	1/8	1.10	2-3/4	4	2-5/16	5-1/2
2	12mm	3/4	2-1/2	1/4	3/8	1-7/16	3/4	15/16	5/32	1.10	2-3/4	4	2-5/16	5-1/2
2-1/2	16mm	3/4	3	3/8	3/8	1-7/16	1	15/16	5/32	1.35	3-1/16	4-1/8	2-3/8	5-7/8
3-1/4	16mm	3/4	3-3/4	1/2	3/8	1-11/16	1	1-3/16	3/16	1.10	3-7/16	4-7/8	2-5/8	6-5/8
4	16mm	3/4	4-1/2	1/2	3/8	1-11/16	1	1-3/16	3/16	1.10	3-7/16	4-7/8	2-5/8	6-5/8

Tie Rods Extend Cap End – Style TC

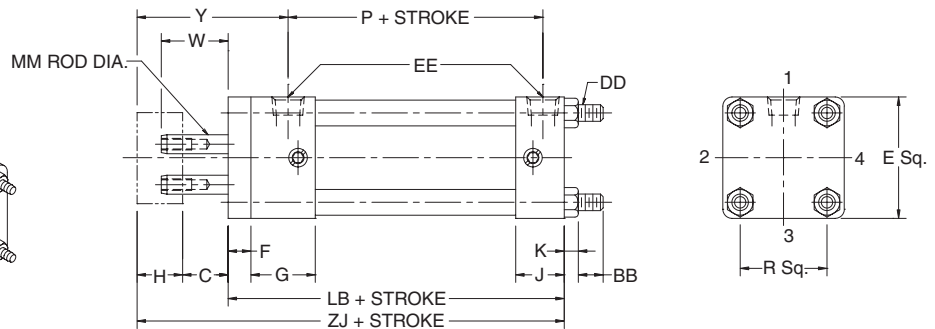
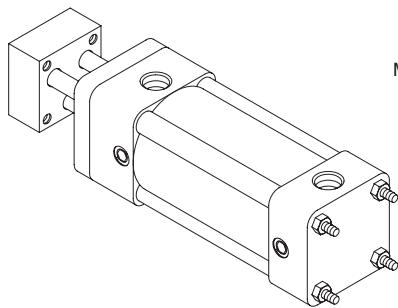

Style TC and Dimensions

Bore	Rod dia. mm	BB	C	DD	E	EE (NPTF)	F	G	H	J	K	R	W	Y	Add stroke		
															LB	P	ZJ
1-1/2	8mm	1	3/4	1/4-28	2	1/4	3/8	1-7/16	3/4	15-16	1/4	1.43	1.10	2-3/4	4	2-5/16	5-1/2
2	12mm	1-1/8	3/4	5/16-24	2-1/2	1/4	3/8	1-7/16	3/4	15-16	5/16	1.84	1.10	2-3/4	4	2-5/16	5-1/2
2-1/2	16mm	1-1/8	3/4	5/16-24	3	3/8	3/8	1-7/16	1	15-16	5/16	2.19	1.35	3-1/16	4-1/8	2-3/8	5-7/8
3-1/4	16mm	1-3/8	3/4	3/8-24	3-3/4	1/2	5/8	1-11/16	1	1-3/16	3/8	2.76	1.10	3-7/16	4-7/8	2-5/8	6-5/8
4	16mm	1-3/8	3/4	3/8-24	4-1/2	1/2	5/8	1-11/16	1	1-3/16	3/8	3.32	1.10	3-7/16	4-7/8	2-5/8	6-5/8

B
Tie Rod Pneumatic Cylinders
4MA Series
4MAJ Series
2MNR Series
ACVB Option
LPSO Option
P1D Series



For inventory, lead time, and kit lookup, visit www.pdnplu.com

Dimensional Data

Head Rectangular Flange – Style J (NFPA MF1)

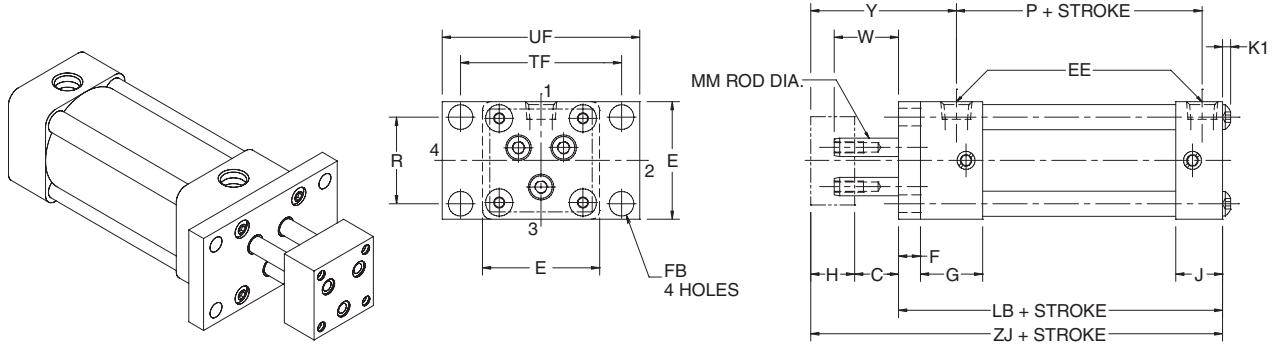

Style J and Dimensions

Bore	Rod dia. mm	C	E	EE (NPTF)	F	FB	G	H	J	K1	R	TF	UF	W	Y	Add stroke		
																LB	P	ZJ
1-1/2	8mm	3/4	2	1/4	3/8	5/16	1-7/16	3/4	15/16	1/8	1.43	2-3/4	3-3/8	1.10	2-3/4	4	2-5/16	5-1/2
2	12mm	3/4	2-1/2	1/4	3/8	3/8	1-7/16	3/4	15/16	5/32	1.84	3-3/8	4-1/8	1.10	2-3/4	4	2-5/16	5-1/2
2-1/2	16mm	3/4	3	3/8	3/8	3/8	1-7/16	1	15/16	5/32	2.19	3-7/8	4-5/8	1.35	3-1/16	4-1/8	2-3/8	5-7/8
3-1/4	16mm	3/4	3-3/4	1/2	3/8	7/16	1-11/16	1	1-3/16	3/16	2.76	4-11/16	5-1/2	1.10	3-7/16	4-7/8	2-5/8	6-5/8
4	16mm	3/4	4-1/2	1/2	3/8	7/16	1-11/16	1	1-3/16	3/16	3.32	5-7/16	6-1/4	1.10	3-7/16	4-7/8	2-5/8	6-5/8

Cap Rectangular Flange – Style H (NFPA MF2)

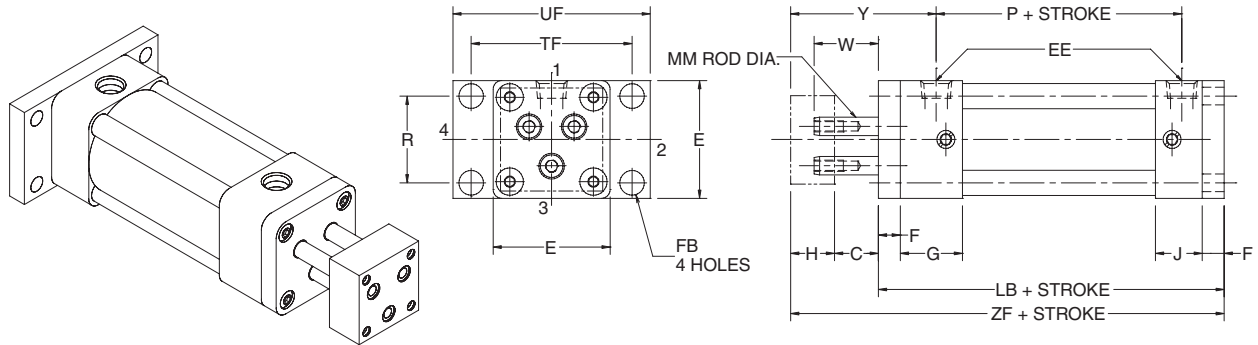

Style H and Dimensions

Bore	Rod dia. mm	C	E	EE (NPTF)	F	FB	G	H	J	R	TF	UF	W	Y	Add stroke		
															LB	P	ZJ
1-1/2	8mm	3/4	2	1/4	3/8	5/16	1-7/16	3/4	15-16	1.43	2-3/4	3-3/8	1.10	2-3/4	4-3/8	2-5/16	5-7/8
2	12mm	3/4	2-1/2	1/4	3/8	3/8	1-7/16	3/4	15-16	1.84	3-3/8	4-1/8	1.10	2-3/4	4-3/8	2-5/16	5-7/8
2-1/2	16mm	3/4	3	3/8	3/8	3/8	1-7/16	1	15-16	2.19	3-7/8	4-5/8	1.35	3-1/16	4-1/2	2-3/8	6-1-4
3-1/4	16mm	3/4	3-3/4	1/2	5/8	7/16	1-11/16	1	1-3/16	2.76	4-11/16	5-1/2	1.10	3-7/16	5-1/2	2-5/8	7-1/4
4	16mm	3/4	4-1/2	1/2	5/8	7/16	1-11/16	1	1-3/16	3.32	5-7/16	6-1/4	1.10	3-7/16	5-1/2	2-5/8	7-1/4

Dimensional Data

2MNR Series

Sleeve Nut (Cap End Only) – Style TE (NFPA MX5)

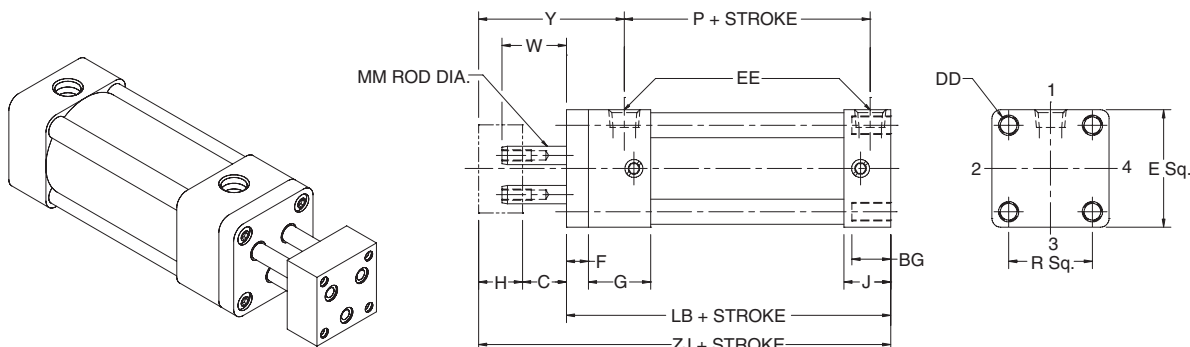

Style TE and Dimensions

Bore	Rod dia. mm	BG	C	DD	E	EE (NPTF)	F	G	H	J	R	W	Y	Add stroke			
														LB	P	ZF	ZJ
1-1/2	8mm	0.45	3/4	1/4-28	2	1/4	3/8	1-7/16	3/4	15/16	1.43	1.10	2-3/4	4	2-5/16	5.10	5-1/2
2	12mm	0.48	3/4	5/16-24	2-1/2	1/4	3/8	1-7/16	3/4	15/16	1.84	1.10	2-3/4	4	2-5/16	5.10	5-1/2
2-1/2	16mm	0.48	3/4	5/16-24	3	3/8	3/8	1-7/16	1	15/16	2.19	1.35	3-1/16	4-1/8	2-3/8	5.35	5-7/8
3-1/4	16mm	0.50	3/4	3/8-24	3-3/4	1/2	3/8	1-11/16	1	1-3/16	2.76	1.10	3-7/16	4-7/8	2-5/8	5.23	6-5/8
4	16mm	0.50	3/4	3/8-24	4-1/2	1/2	3/8	1-11/16	1	1-3/16	3.32	1.10	3-7/16	4-7/8	2-5/8	5.98	6-5/8

Side Tapped Mount – Style F (NFPA MS4)

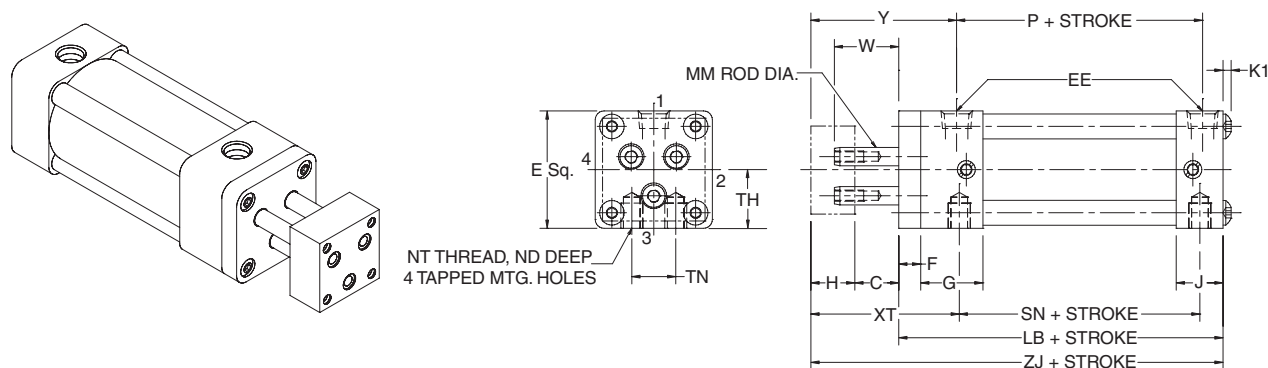

Style TC and Dimensions

Bore	Rod dia. mm	C	E	EE (NPTF)	F	G	H	J	K1	ND	NT	TH ±0.003	TN	W	XT	Y	Add stroke			
																	LB	P	SN	ZJ
1-1/2	8mm	3/4	2	1/4	3/8	1-7/16	3/4	15-16	1/8	3/8	1/4-20	0.993	5/8	1.10	2-13/16	2-3/4	4	2-5/16	2-1/4	5-1/2
2	12mm	3/4	2-1/2	1/4	3/8	1-7/16	3/4	15-16	5/32	7/16	5/16-18	1.243	7/8	1.10	2-13/16	2-3/4	4	2-5/16	2-1/4	5-1/2
2-1/2	16mm	3/4	3	3/8	3/8	1-7/16	1	15-16	5/32	5/8	3/8-16	1.493	1-1/4	1.35	3-1/16	3-1/16	4-1/8	2-3/8	2-3/8	5-7/8
3-1/4	16mm	3/4	3-3/4	1/2	5/8	1-11/16	1	1-3/16	3/16	3/4	1/2-13	1.868	1-1/2	1.10	3-7/16	3-7/16	4-7/8	2-5/8	2-3/8	6-5/8
4	16mm	3/4	4-1/2	1/2	5/8	1-11/16	1	1-3/16	3/16	3/4	1/2-13	2.243	2-1/16	1.10	3-7/16	3-7/16	4-7/8	2-5/8	2-3/8	6-5/8

B

Tie Rod Pneumatic Cylinders

4MA Series

4MAJ Series

2MNR Series

ACVB Option

LPSO Option

P1D Series



For inventory, lead time, and kit lookup, visit www.pdnplu.com

Dimensional Data

Cap Detachable Clevis – Style BC (NFPA MP2)

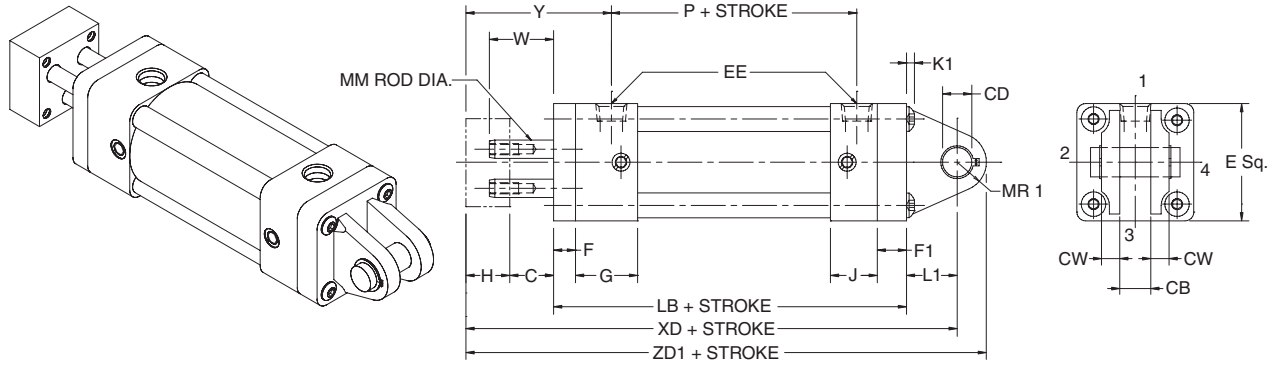

Style BC and Dimensions

Bore	Rod dia. mm	C	CB	CD +.000 -.002	CW	E	EE (NPTF)	F	F1	G	H	J	K1	L1	MR1	W	Y	Add stroke			
																		LB	P	XD	ZD1
1-1/2	8mm	3/4	3/4	0.501	1/2	2	1/4	3/8	3/8	1-7/16	3/4	15/16	1/8	3/4	1/2	1.10	2-3/4	4-3/8	2-5/16	6-5/8	7-1/8
2	12mm	3/4	3/4	0.501	1/2	2-1/2	1/4	3/8	3/8	1-7/16	3/4	15/16	5/32	3/4	1/2	1.10	2-3/4	4-3/8	2-5/16	6-5/8	7-1/8
2-1/2	16mm	3/4	3/4	0.501	1/2	3	3/8	3/8	3/8	1-7/16	1	15/16	5/32	3/4	1/2	1.35	3-1/16	4-1/2	2-3/8	7	7-1/2
3-1/4	16mm	3/4	1-1/4	0.751	5/8	3-3/4	1/2	3/8	5/8	1-11/16	1	1-3/16	3/16	1-1/4	3/4	1.10	3-7/16	5-1/2	2-5/8	8-1/2	9-1/4
4	16mm	3/4	1-1/4	0.751	5/8	4-1/2	1/2	3/8	5/8	1-11/16	1	1-3/16	3/16	1-1/4	3/4	1.10	3-7/16	5-1/2	2-5/8	8-1/2	9-1/4

Cap Fixed Clevis – Style BB (NFPA MP1)

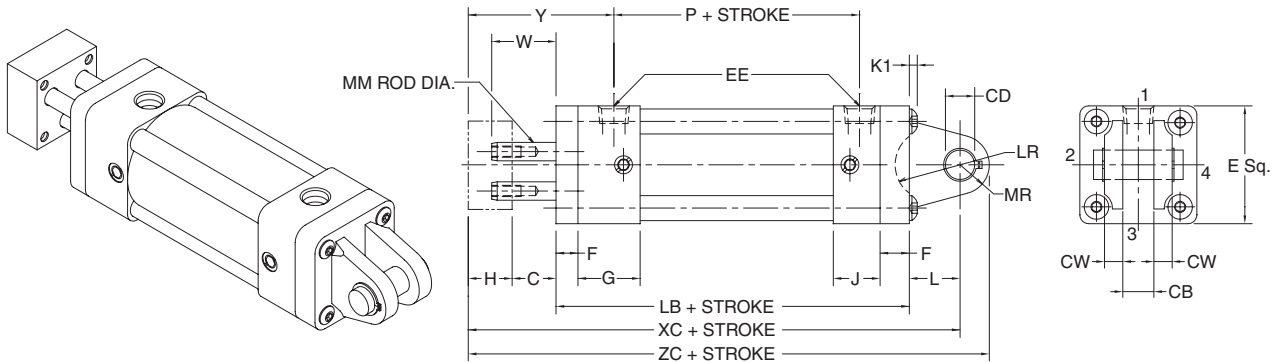

Style BB and Dimensions

Bore	Rod dia. mm	C	CB	CD +.000 -.002	CW	E	EE (NPTF)	F	G	H	J	L	LR	MR	W	Y	Add stroke			
																	LB	P	XC	ZC
1-1/2	8mm	3/4	3/4	0.501	1/2	2	1/4	3/8	1-7/16	3/4	15-16	15/16	3/4	5/8	1.10	2-3/4	4-3/8	2-5/16	6-1/4	6-7/8
2	12mm	3/4	3/4	0.501	1/2	2-1/2	1/4	3/8	1-7/16	3/4	15-16	15/16	3/4	5/8	1.10	2-3/4	4-3/8	2-5/16	6-1/4	6-7/8
2-1/2	16mm	3/4	3/4	0.501	1/2	3	3/8	3/8	1-7/16	1	15-16	15/16	3/4	5/8	1.35	3-1/16	4-1/2	2-3/8	6-5/8	7-1/4
3-1/4	16mm	3/4	1-1/4	0.751	5/8	3-3/4	1/2	5/8	1-11/16	1	1-3/16	1-3/16	1	15/16	1.10	3-7/16	5-1/2	2-5/8	7-7/8	8-13/16
4	16mm	3/4	1-1/4	0.751	5/8	4-1/2	1/2	5/8	1-11/16	1	1-3/16	1-3/16	1	15/16	1.10	3-7/16	5-1/2	2-5/8	7-7/8	8-13/16

Dimensional Data

Detachable Pivot Eye – Style BE (NFPA MP4)

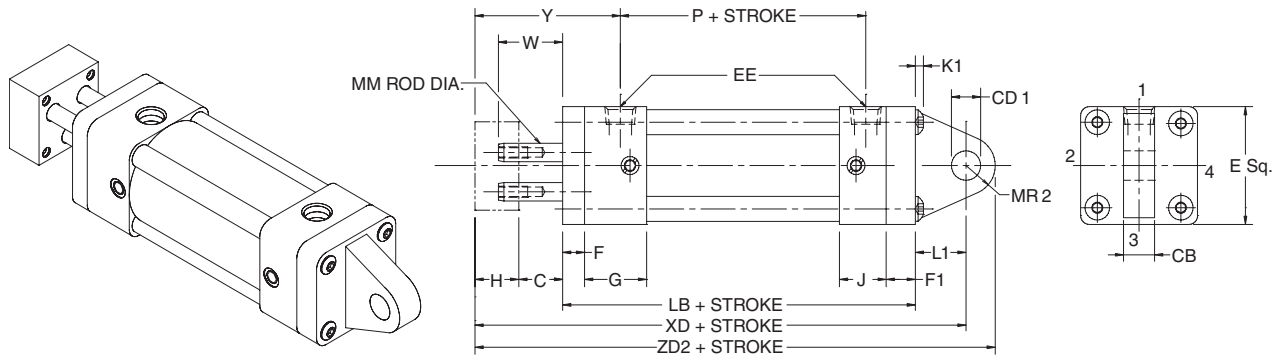

Style BE and Dimensions

Bore	Rod dia. mm	C	CB	CD +.000 -.002	E	EE (NPTF)	F	F1	G	H	J	K1	L1	MR2	W	Y	Add stroke			
																	LB	P	XD	ZD2
1-1/2	8mm	3/4	3/4	0.500	2	1/4	3/8	3/8	1-7/16	3/4	15/16	1/8	3/4	5/8	1.10	2-3/4	4-3/8	2-5/16	6-5/8	7-1/4
2	12mm	3/4	3/4	0.500	2-1/2	1/4	3/8	3/8	1-7/16	3/4	15/16	5/32	3/4	5/8	1.10	2-3/4	4-3/8	2-5/16	6-5/8	7-1/4
2-1/2	16mm	3/4	3/4	0.500	3	3/8	3/8	3/8	1-7/16	1	15/16	5/32	3/4	11/16	1.35	3-1/16	4-1/2	2-3/8	7	7-11/16
3-1/4	16mm	3/4	1-1/4	0.750	3-3/4	1/2	3/8	5/8	1-11/16	1	1-3/16	3/16	1-1/4	7/8	1.10	3-7/16	5-1/2	2-5/8	8-1/2	9-3/8
4	16mm	3/4	1-1/4	0.750	4-1/2	1/2	3/8	5/8	1-11/16	1	1-3/16	3/16	1-1/4	7/8	1.10	3-7/16	5-1/2	2-5/8	8-1/2	9-3/8

Base Bar – Style NB

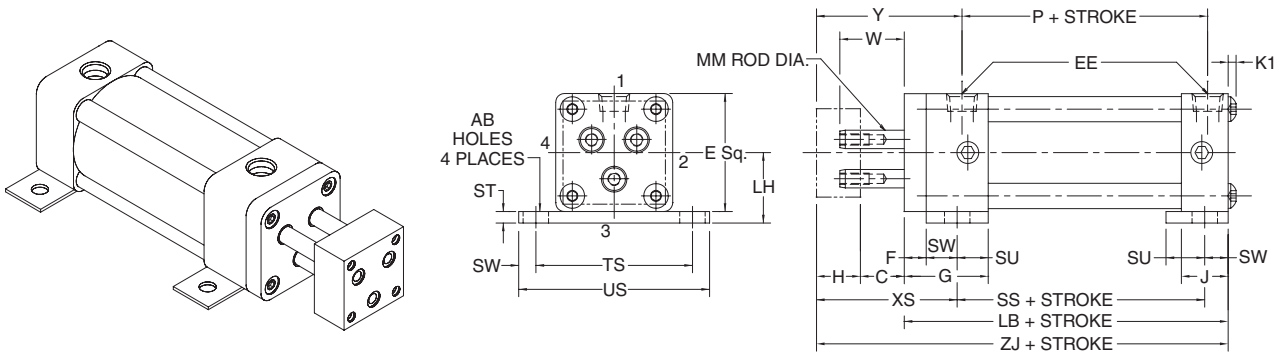

Style NB and Dimensions

Bore	Rod dia. mm	AB	C	E	EE (NPTF)	F	G	H	J	K1	LH ±.000	ST	SU	SW	TS	US	W	XS	Y	Add stroke			
																				LB	P	SS	ZJ
1-1/2	8mm	7/16	3/4	2	1/4	3/8	1-1/2	3/4	15-16	1/8	15/16	1/4	1-1/8	3/8	2-3/4	3-1/2	1.10	2-1/4	2-3/4	4	2-5/16	2-7/8	5-1/2
2	12mm	7/16	3/4	2-1/2	1/4	3/8	1-1/2	3/4	15-16	5/32	15/16	1/4	1-1/8	3/8	3-1/4	4	1.10	2-1/4	2-3/4	4	2-5/16	2-7/8	5-1/2
2-1/2	16mm	7/16	3/4	3	3/8	3/8	1-1/2	1	15-16	5/32	15/16	3/8	1-1/8	3/8	3-3/4	4-1/2	1.35	2-1/2	3-1/16	4-1/8	2-3/8	3	5-7/8
3-1/4	16mm	9/16	3/4	3-3/4	1/2	5/8	1-3/4	1	1-3/16	3/16	1-3/16	1/2	1-1/4	1/2	4-3/4	5-3/4	1.10	2-7/8	3-7/16	4-7/8	2-5/8	3-1/4	6-5/8
4	16mm	9/16	3/4	4-1/2	1/2	5/8	1-3/4	1	1-3/16	3/16	1-3/16	1/2	1-1/4	1/2	5-1/2	6-1/2	1.10	2-7/8	3-7/16	4-7/8	2-5/8	3-1/4	6-5/8

B

Tie Rod Pneumatic
Cylinders

4MA
Series

4MAJ
Series

2MNR
Series

ACVB
Option

LPSO
Option

P1D
Series



For inventory, lead time, and kit
lookup, visit www.pdnplu.com

B101

Parker Hannifin Corporation
Pneumatic Division
Richland, Michigan
www.parker.com/pneumatics

Dimensional Data

Double End – Style K

Three rods with tooling plate one end
 Single rod on the opposite end

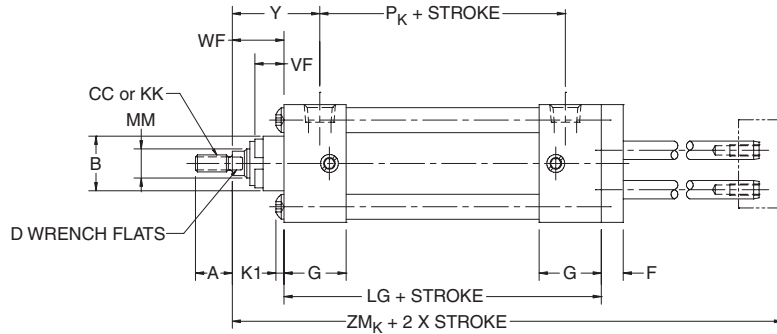
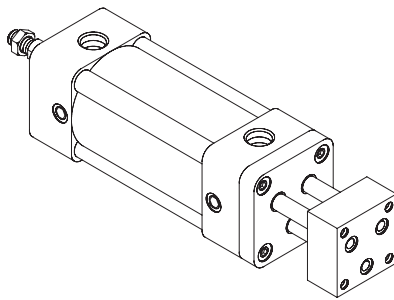

Style K and Dimensions

Bore	Rod no.	Rod dia. mm	Thread style		A	B +.000 -.002	C	D	F	G	H	K1	VF	WF	Y
			8 CC	4 & 9 KK											
1-1/2	1	5/8	1/2-20	7/16-20	3/4	1.124	3/4	1/2	3/8	1-7/16	3/4	1/8	5/8	1	1-7/8
2	1	5/8	1/2-20	7/16-20	3/4	1.124	3/4	1/2	3/8	1-7/16	3/4	5/32	5/8	1	1-7/8
2-1/2	1	5/8	1/2-20	7/16-20	3/4	1.124	3/4	1/2	3/8	1-7/16	1	5/32	5/8	1	1-15/16
3-1/4	1	1	7/8-14	3/4-16	1-1/8	1.499	3/4	7/8	5/8	1-11/16	1	3/16	3/4	1-3/8	2-7/16
4	1	1	7/8-14	3/4-16	1-1/8	1.499	3/4	7/8	5/8	1-11/16	1	3/16	3/4	1-3/8	2-7/16

Bore	Add stroke				Add 2X stroke	
	LG	SSK	SNK	PK	ZMK	ZMR
1-1/2	4-1/8	3-3/8	2-1/4	2-3/8	7	7-7/8
2	4-1/8	3-3/8	2-1/4	2-3/8	7	7-7/8
2-1/2	4-1/4	3-1/2	2-3/8	2-3/8	7-3/8	8-1/2
3-1/4	4-3/4	3-3/4	2-5/8	2-5/8	8-1/2	9-1/2
4	4-3/4	3-3/4	2-5/8	2-5/8	8-1/2	9-1/2

Replaces dimension SS SN
 On mtg. style NB F

Standard Tooling Plate – Style T

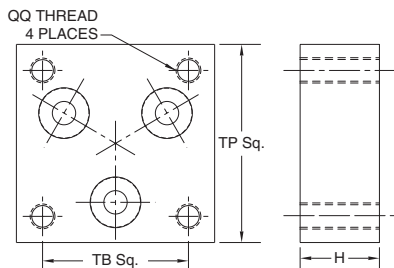

Bore	H	QQ	TB	TP
1-1/2	3/4	10-32	1.12	1-1/2
2	3/4	1/4-28	1.43	2
2-1/2	1	5/16-24	1.84	2-1/2
3-1/4	1	3/8-24	2.19	3-1/4
4	1	3/8-24	2.76	4



For inventory, lead times, and kit lookup, visit www.pdnplu.com

Accessories and Service Kits

**Tie Rod Pneumatic Cylinders
2MNR Series**

Mounting Plate & Eye Bracket

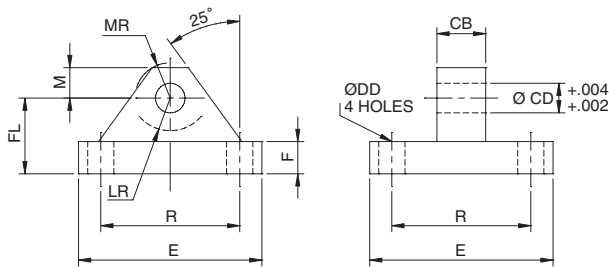

Mounting Plate & Eye Bracket Dimensions

Bore size	1-1/2, 2, 2-1/2	3-1/4, 4
Part number	1458060050	1458060075
CB	3/4	1-1/4
CD	1/2	3/4
DD	13/32	17/32
E	2-1/2	3-1/2
F	3/8	5/8
FL	1-1/8	1-7/8
LR	3/4	1-1/4
M	1/2	3/4
MR	9/16	7/8
R	1.63	2.55

Seal Kits

Bore size	Part number	
	Standard seal kit	Fluorocarbon seal kit
1-1/2	SG2MNR1501	SG2MNR1505
2	SG2MNR2001	SG2MNR2005
2-1/2	SG2MNR2501	SG2MNR2505
3-1/4	SG2MNR3201	SG2MNR3205
4	SG2MNR4001	SG2MNR4005

Clevis Bracket

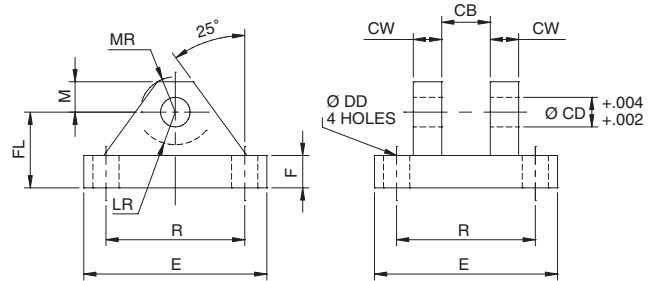

Clevis Bracket Dimensions

Bore size	1-1/2, 2, 2-1/2	3-1/4, 4
Part number	1458050050	1458050075
CB	3/4	1-1/4
CD	1/2	3/4
CW	1/2	5/8
DD	13/32	17/32
E	3-1/2	5
F	1/2	5/8
FL	1-1/2	1-7/8
LR	3/4	1-3/16
M	1/2	3/4
MR	5/8	2/32
R	2.55	3.82

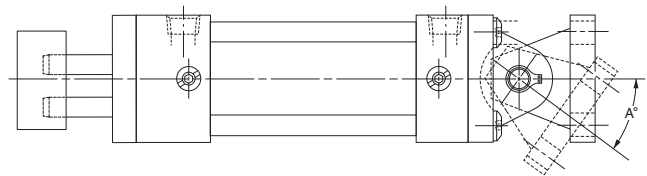

Bore size	1-1/2	2	2-1/2	3-1/4	4
Angle A *	52	43	29	50	49

* Angle of rotation specified is for BB style mount only.

Pivot Pin

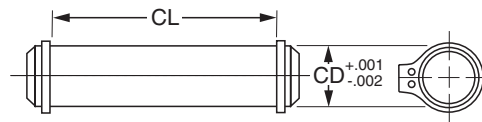

Pivot Pin Dimensions

Part number	0856640050	0856640075
CD	1/2	3/4
CL	1-7/8	2-5/8

B

Tie Rod Pneumatic Cylinders

4MA Series

4MAJ Series

2MNR Series

ACVB Option

LPSO Option

P1D Series



For inventory, lead time, and kit lookup, visit www.pdnplu.com

Options

P1D Series – ISO Pneumatic Cylinders

P

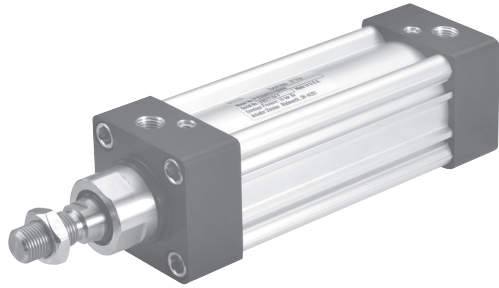
Tie Rod Pneumatic
Cylinders4MA
Series4MAJ
Series2MNR
SeriesACVB
OptionLPSO
OptionP1D
Series

P1D Removable Gland Version

P1D Removable Gland Version cylinders are available in 32-200mm bores and utilize bar stock endcaps and a removable high-strength bronze bearing for traditional and custom applications. The bronze bearing assembly is externally removable for quick and easy maintenance. No other ISO cylinder manufacturer in the world produces a Removable Gland Version and meets these demands. This version covers all applications which require performance and customization at all bore sizes.

Removable Gland

An extra-long inboard bearing surface ensures lubrication from within the cylinder. Outboard of the bearing are two leak-proof seals. The rod wiper seal wipes away any dirt on the rod. This means less wear on bearing surfaces and internal parts. The result is positive, no-leak sealing, regardless of conditions. And with the famous Parker removable style gland, you can replace the rod seals and/or bearings when necessary without disassembling the rest of the cylinder and without the need of any special wrenches.

Aluminum Piston Option

For high temperature applications, an aluminum piston is available with fluorocarbon seals. The piston is threaded onto the piston rod and secured in place with anaerobic adhesive which is temperature sensitive. For applications above 121°C (250°F) specify a pinned piston to rod connection. The polyurethane seals that are standard on the nylon piston are also an available option with the aluminum piston. The magnet that is cleverly hidden underneath the wear-band is also a standard feature on the aluminum piston. The durable wear-band prevents any metal-to-metal contact between the piston and the cylinder body wall increasing the overall life of the cylinder.

Machined End Caps with Captive Cushion Screw Adjustment

The end caps are made of precision lightweight aluminum. This allows for maximum flexibility and quick manufacturing for any customization that is required. The end caps also feature a captive cushion needle valve adjustment screw for optimized cushioning that is inherent throughout the P1D family of ISO cylinders.

P1D Series Rod Lock Cylinder

The P1D Series Rod Lock Cylinder incorporates a powerful piston rod locking device, which clamps the piston rod and locks it in position. The locking device is a spring lock with an air pressure release and is integrated into the front (head) cover of the cylinder.

In the absence of air signal pressure, full holding force is applied to the piston rod. When air is present at 4 bar (58 psi), the locking device is released.

The P1D Series Rod Lock Cylinder is available for cylinder bores 32-125mm. The design provides several valuable characteristics, such as:

- A holding force corresponding to a pressure of 7 bar (102 psi)
- A clean design, with the front (head) end cover and locking device built into a common block for compact installation
- Easy to clean, well-sealed construction
- Exhaust air from the locking device can be piped away when there are high demands for a contaminant free environment



P1D Series Rod Lock Cylinder with Manual Override

The P1D Series Rod Lock Cylinder with Manual Override is available for rod lock release during non-production activities. It incorporates the same features as the standard rod lock cylinder.



Options

P1D Tie-Rod Version

The P1D Tie-Rod Version cylinders are based on the same high level technology as the Removable Gland Version. This cylinder is the perfect choice wherever a true tie-rod cylinder is needed.

International standards

The P1D Tie-Rod Version complies with ISO 6431, ISO/DIS 15552, VDMA 24562 and AFNOR installation dimension standards, for customer reassurance world-wide.

“Drop-in” sensor

The P1D Tie-Rod Version utilizes the same drop-in Global Sensors as the other versions. An ingenious multi-jointed adapter clamps the sensors to the tie rod in any chosen position along the stroke.

Large Bore Sizes

The P1D Tie-Rod Version is now available in 160 and 200mm bore sizes.

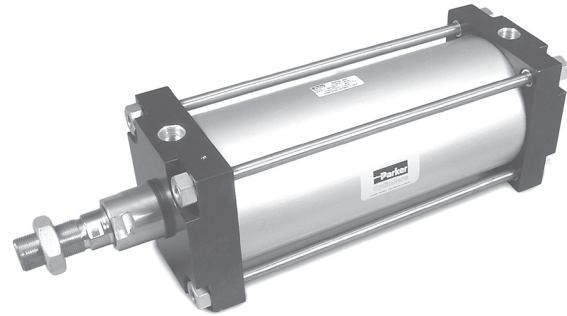

32-125mm bores

Guided Cylinders

For guided versions of the P1D, see the P5E Series and HB Series.



P5E Series

B

Tie Rod Pneumatic Cylinders

4MA Series

4MAJ Series

2MNR Series

ACVB Option

LPSO Option

P1D Series

Features

The innovative P1D is a long lasting ISO/VDMA cylinder. The cylinders are double acting, with a new design of air cushioning.

The P1D complies with the current ISO 6431, ISO 15552, VDMA 24562 and AFNOR installation dimension standards

- Available in 32 to 200mm bores
- PUR seals for long service life
- Drop-in sensors
- Corrosion resistant design
- Magnetic piston as standard
- Lubricated with food grade grease



Operating information

Operating pressure:	145 PSIG (10 bar) maximum
Temperature range:	Standard: -4°F to 176°F (-20°C to 80°C) High temperature: 14°F to 250°F (-10°C to 121°C)
Cylinders for low pressure hydraulic operation:	Ø32 - 125mm
Filtration requirements:	40 micron, dry filtered air

Sensors

See section L for sensors.



B	Tie Rod Pneumatic Cylinders
Series	4MA
Series	4MAJ
Series	2MNR
Option	ACVB
Option	LPS0
Series	P1D

Most popular.



For inventory, lead times, and kit lookup, visit www.pdnplu.com

B106

Parker Hannifin Corporation
 Pneumatic Division
 Richland, Michigan
www.parker.com/pneumatics

Ordering information

P1D	-	G	032	M	C	-	0500	N	N	N	N	N
------------	----------	----------	------------	----------	----------	----------	-------------	----------	----------	----------	----------	----------

Piston Style			Bore size		Stroke ¹⁴		Rod end	
Cushions	Piston material		032	32mm	Specify whole mm using 4 digits, i.e. 0500		N	Metric male
	Composite ¹	Aluminum	040	40mm			6	Metric female
None	M	Y	050	50mm			3	Special*
Cush B/E	- ³	4	063	63mm			* Please provide desired dimensions for KK, AM and WH or W. If otherwise, please provide dimensioned sketch.	
Cush head	J	5	080	80mm				
Cush cap	K	6	100	100mm				
			125	125mm				
			160	160mm ⁸				
			200	200mm ⁸				

Version				
	Cylinder body	Rod lock		
		None	Fitted w/ standard rod lock ⁷	Fitted w/ manual override rod lock ⁷
Machined end caps rod lock not available with removable gland. ⁵	Profile	G ⁵	R	J
	Tie Rod ¹³	E ⁵	7 ⁴	Consult Factory
Special ⁶	Any Special	/		

Function				
Fastener type	Rod wiper style	Double acting	Double rod	Tandem ¹³
Standard end cover screws	Std scraper	M	F	C
	Metal scraper	Q	R	J
Stainless steel end cover screws ⁹	Std scraper	A	G	N/A
	Metal scraper	S	T	N/A

Piston rod & seal material		
Piston rod material	Seal material	
	Standard	Fluorocarbon ¹⁰
Chrome plated carbon steel	C	G
Chrome plated stainless steel	R	D
Acid-resistant stainless steel	M	N

Cylinder ports front & rear	
-	BSPP Ports (G Threads)**
E	NPTF Ports*

** ISO 1179-1 with ISO 228-1 threads.

Rod mountings	
Rod mounting	
Swivel rod eye	S
Swivel rod eye SS	T
Swivel rod eye with clevis bracket GA ¹⁹	V
Swivel rod eye SS with clevis bracket GA	W
Clevis	C
Clevis SS	D
Flexco coupling	F
One additional piston rod nut	X
Stainless steel piston rod nut	Y
Acid-resistant nut	Z
None (piston rod nut only)	N

Sensors ¹⁷		
P1D prepared for sensors		N

Mounting style		
	Standard	Rotated 90°
Flange MF1 at head (front) end	1	3
Flange MF2 at cap (rear) end	B	4
Flanges MF1 and MF2 at both ends	2	K
Foot brackets MS1	F	R
Clevis bracket GA aluminum	C	U
Rear eye MP4 aluminum	E	V
Rear swivel eye MP6 aluminum	S	W
Clevis bracket MP2 aluminum	T	Y
Rear eye + clevis (MP4 + MP2) aluminum	L	Z
Clevis bracket MP2 + pivot hinge aluminum	X	5
Clevis bracket GA aluminum + steel swivel hinge	Q	0
Rear swivel eye + clevis bracket GA aluminum	M	A
Intermediate trunnion MT4 (requires XV dimension)	G	7
Trunnion flange at head (front) end ⁴	H	P
Trunnion flange at cap (rear) end ⁴	J	8
None (MX0)	N	9

Notes:

- Not available for 160-200mm bores.
- Must be placed in model code.
- Not available for 160-200mm bores or with fluorocarbon seals.
- When Removable Gland Version is fitted with rod lock, gland cannot be replaced without disassembling cylinder.
- If special cylinder is ordered (other than rod end), End Cap Style, Cylinder Body Profile and Rod Lock option must be given in addition to the special request.
- Tie Rod Version E must be specified for these bores.
- Applies only to end cover screws for 32-125mm bores. For stainless steel tie rods and nuts (all bore sizes), change Version to special and request stainless steel tie rods and nuts.
- If used for temperature above 80°C (176°F), aluminum piston required.
- Tie Rod Version is required for Tandem Function.
- When specifying a stop tube, place a "/" in the version field. Then specify the version, amount of stop tube and amount of net stroke. The stroke used in the model code should be gross stroke (net stroke plus stop tube).
- For sensor part numbers and specifications, please refer to Electronic Sensors section.
- Consult factory for this option.

Double Rod Cylinders
Double rod option is available with Mounting Styles MX0, MS1, MF1, MF2 and MT4.
For double rod cylinders, it is assumed that the rod number and rod end are the same for both piston rods. On a double rod cylinder where the two rod ends are different, use a rod end of '3' and be sure to clearly state which rod end is to be assembled at which end.

B

Tie Rod Pneumatic Cylinders

4MA Series

4MAJ Series

2MNR Series

ACVB Option

LPSO Option

P1D Series

For ordering purposes, when special options or common modifications are requested, the factory will assign a sequential part number in place of the model number.



For inventory, lead time, and kit lookup, visit www.pdnplu.com

B107

Parker Hannifin Corporation
Pneumatic Division
Richland, Michigan
www.parker.com/pneumatics

Specifications

General Specifications

- Bore sizes 32-200mm
- Max stroke 2800mm
- Min stroke 25mm
(must specify Tie Rod Version for strokes <25mm)
- Rod Ends – 2 standard, specials to order
- Single rod end and double rod end styles
- Working pressure Max 10 bar (145 PSI)
- Working temperature –
-20°C to 80°C (-4°F to 176°F) standard
-10°C to 121°C (14°F to 250°F) high temp version
- Aluminum piston is required for service above 80°C (176°F)
- Greased for life (non-lube), does not normally need additional lubrication. If air line lubrication is initiated, it must always be continued.
- Working medium: Dry, filtered compressed air to ISO 8573-1 class 3. 4. 3. or better

P1D Rod Lock Version

- Fluid Medium: Dry, filtered, compressed air
 - Maximum Cylinder Operating Pressure: 10 bar (145 PSI)
 - Required Pressure to Unlock¹: 4 bar (58 PSI)
 - Minimum Torque Required for Manual Override Version:
 - 32mm Bore = 0.9 N-m / 8 in-lbs
 - 40mm Bore = 0.9 N-m / 8 in-lbs
 - 50mm Bore = 2.7 N-m / 24 in-lbs
 - 63mm Bore = 2.7 N-m / 24 in-lbs
 - 80mm Bore = 27.1 N-m / 240 in-lbs
 - 100mm Bore = 36.6 N-m / 324 in-lbs
 - 125mm Bore = 61.0 N-m / 540 in-lbs
 - Operating Temperature:
 - 10°C to 75°C (14°F to 167°F)
 - Min stroke 10mm
 - Maximum Cylinder Operating Speed: 5 feet per second
- ¹ Signal pressure to port on locking device. Operation at pressures lower than 4 bar (58 psi) may lead to inadvertent engagement of the rod lock device.

Quick Reference

Bore size	Cylinder area, cm ²	Piston rod			Cushioning length mm	Air consumption ¹ liter	Connection thread ⁴	Theoretical cylinder forces at 6 bar (N) ²	
		Dia. mm	Area, cm ²	Male thread				Extend stroke	Retract stroke
32	8.0	12	1.1	M10x1.25	17	0.105	G1/8	482	414
40	12.6	16	2.0	M12x1.25	19	0.162	G1/4	754	633
50	19.6	20	3.1	M16x1.5	20	0.253	G1/4	1178	989
63	31.2	20	3.1	M16x1.5	23	0.414	G3/8	1870	1681
80	50.3	25	4.9	M20x1.5	23	0.669	G3/8	3016	2721
100	78.5	25	4.9	M20x1.5	27	1.043	G1/2	4712	4417
125	122.7	32	8.0	M27x2	30	1.662	G1/2	7363	6880
160	201.1	40	12.6	M36x2	38	2.724	G3/4	12,064	11,310
200	314.2	40	12.6	M36x2	38	4.256	G3/4	18,850	18,096

Cylinder bore size	Total mass (kg)				Total mass (kg) moving components			Adder for rod lock
	0mm stroke ³		Supplement per 10mm stroke		at 0mm stroke	Supplement per 10mm stroke		
	Basic	Tie-Rod	Basic	Tie-Rod				
32	0.55	0.54	0.023	0.022	0.13	0.009	0.41	
40	0.80	0.79	0.033	0.030	0.24	0.016	0.44	
50	1.20	1.20	0.048	0.048	0.42	0.025	0.61	
63	1.73	1.73	0.051	0.051	0.50	0.025	1.25	
80	2.45	2.47	0.075	0.079	0.90	0.039	2.45	
100	4.00	4.00	0.084	0.084	1.10	0.039	3.72	
125	6.87	6.73	0.138	0.129	2.34	0.063	6.07	
160	–	16.19	–	0.160	Consult Factory	Consult Factory	Consult Factory	
200	–	22.23	–	0.185	Consult Factory	Consult Factory	Consult Factory	

1 Free air consumption per 10mm stroke for a double stroke at 6 bar
 2 The values for cylinder forces are theoretical and should be reduced to suit working conditions.
 3 Total Mass for composite piston for 32-125mm bores and aluminum piston for 160-200mm bores.
 4 ISO 1179-1 with ISO 228-1 threads



For inventory, lead times, and kit lookup, visit www.pdnplu.com

Material Specifications

Piston Rod Material Options

(or with equivalent properties):

Standard	Case-hardened, chrome plated carbon steel
Chrome plated stainless steel	17-4 PH, chrome plated stainless steel
Acid-resistant stainless steel	316 stainless steel



Tie Rod Pneumatic Cylinders P1D Series

Additional/Substitute Specifications

P1D Tie-Rod Version

Tie-rods	Blackened steel
----------	-----------------

P1D Removable Gland Version

End covers	Black anodized aluminum
End cover screws	Zinc plated steel 8.8 (32-125mm bores)
Cylinder Body	Clear anodized aluminum
Rod gland	PTFE filled high strength bronze
Rod seal	Buna Nitrile for sealing action
Rod wiper	Buna Nitrile for wiping action
Piston rod	Case hardened chrome-plated steel
Piston rod nut	Zinc plated steel
Piston	POM (standard) Aluminum (optional)
Piston seals	PUR
Piston bearing	POM or Molyguard wear band for aluminum piston
Magnetic ring	Plastic bound magnetic material
Piston fastener	Zinc plated steel (composite piston)
O-rings	Buna Nitrile
Cushioning seals	PUR
Cushioning screws	Stainless steel (brass for 160 and 200mm bores)

Design Variants for Removable Gland Version

High temperature option includes:

All seals	Fluorocarbon
Piston	Aluminum (without magnetic ring)

Low pressure hydraulic option includes:

Rod seal	Buna Nitrile
Rod wiper	NBR
Piston seals	Buna Nitrile
Piston	Aluminum (non-cushioned)

Metallic Rod Scraper includes:

Rod wiper	Dual high strength bronze wipers with nitrile or fluorocarbon energizer
-----------	---

B

Tie Rod Pneumatic Cylinders

4MA Series

4MAJ Series

2MNR Series

ACVB Option

LPSO Option

P1D Series



Cushioning Characteristics

The diagram below is used for sizing of cylinders related to the cushioning capacity. The maximum cushioning capacity shown in the diagram assumes the following:

- Low load, i.e. low pressure drop across the piston
- Equilibrium speed
- Correctly adjusted cushioning screw
- 6 bar at cylinder port

The load is the sum of internal and external friction, plus any gravitational forces. At high relative load (pressure drop exceeding 1 bar), we recommend that for any given speed, the mass should be reduced by a factor of 2.5, or for a given mass, the speed should be reduced by a factor of 1.5. This is in relation to the maximum performance given in the diagram.

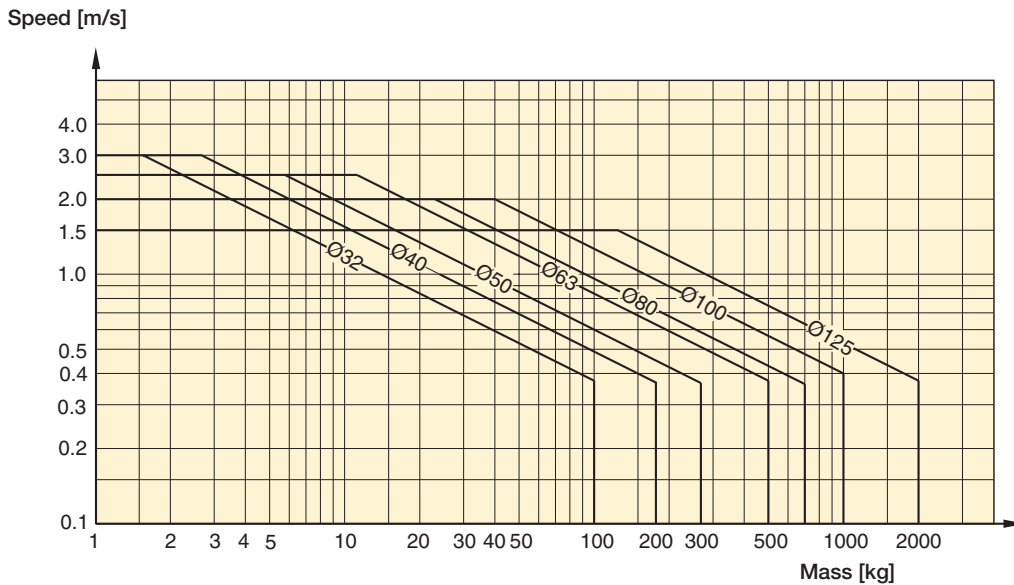

Recommended Air Quality for Cylinders

For best possible service life and trouble-free operation, ISO 8573-1 quality class 3.4.3 should be used. This means 5 µm filter (standard filter) dew point 3°C (37°F) for indoor operation (a lower dew point should be selected for outdoor operation) and oil concentration 1.0 mg oil/m³, which is what a standard compressor with a standard filter gives.

ISO 8573-1 Quality Classes

Quality class	Pollution		Water		Oil
	Particle size (mm)	Max. concentration (mg/m ³)	Max pressure dew point (°C)	Max pressure dew point (°F)	Max. concentration (mg/m ³)
1	0.1	0.1	-70	-94	0.01
2	1	1	-40	-40	-0.1
3	5	5	-20	-4	1.0
4	15	8	+3	+37	5.0
5	40	10	+7	+44	25
6	-	-	+10	+50	-

B
 Tie Rod Pneumatic Cylinders
 4MA Series
 4MAJ Series
 2MNR Series
 ACVB Option
 LPSO Option
 P1D Series



For inventory, lead times, and kit lookup, visit www.pdnplu.com

Guide for Selecting Suitable Tubing

The selection of the correct size of tubing is often based on experience, with no great thought to optimizing energy efficiency and cylinder velocity. This is usually acceptable, but making a rough calculation can result in worthwhile economic gains.

The following is the basic principle:

1. The primary line to the working valve could be oversized (this does not cause any extra air consumption and consequently does not create any extra costs in operation).
2. The tubes between the valve and the cylinder should, however, be optimized according to the principle that an insufficient bore throttles the flow and thus limits the cylinder speed, while an oversized pipe creates a dead volume which increases the air consumption and filling time.

The chart below is intended to help when selecting the correct size of tube to use between the valve and the cylinder.

The following prerequisites apply:

The cylinder load should be about 50% of the theoretical force (= normal load). A lower load gives a higher velocity and vice versa. The tube size is selected as a function of the cylinder bore, the desired cylinder velocity and the tube length between the valve and the cylinder.

If you want to use the capacity of the valve to its maximum, and obtain maximum speed, the tubing should be chosen so that they at least correspond with the equivalent restriction diameter (see description below), so that the tubing does not restrict the total flow. This means that a short tubing must have at least the equivalent restriction diameter. If the tubing is longer, choose it from the table below. Straight fittings should be chosen for highest flow rates. (Elbow and banjo fittings cause restriction.)

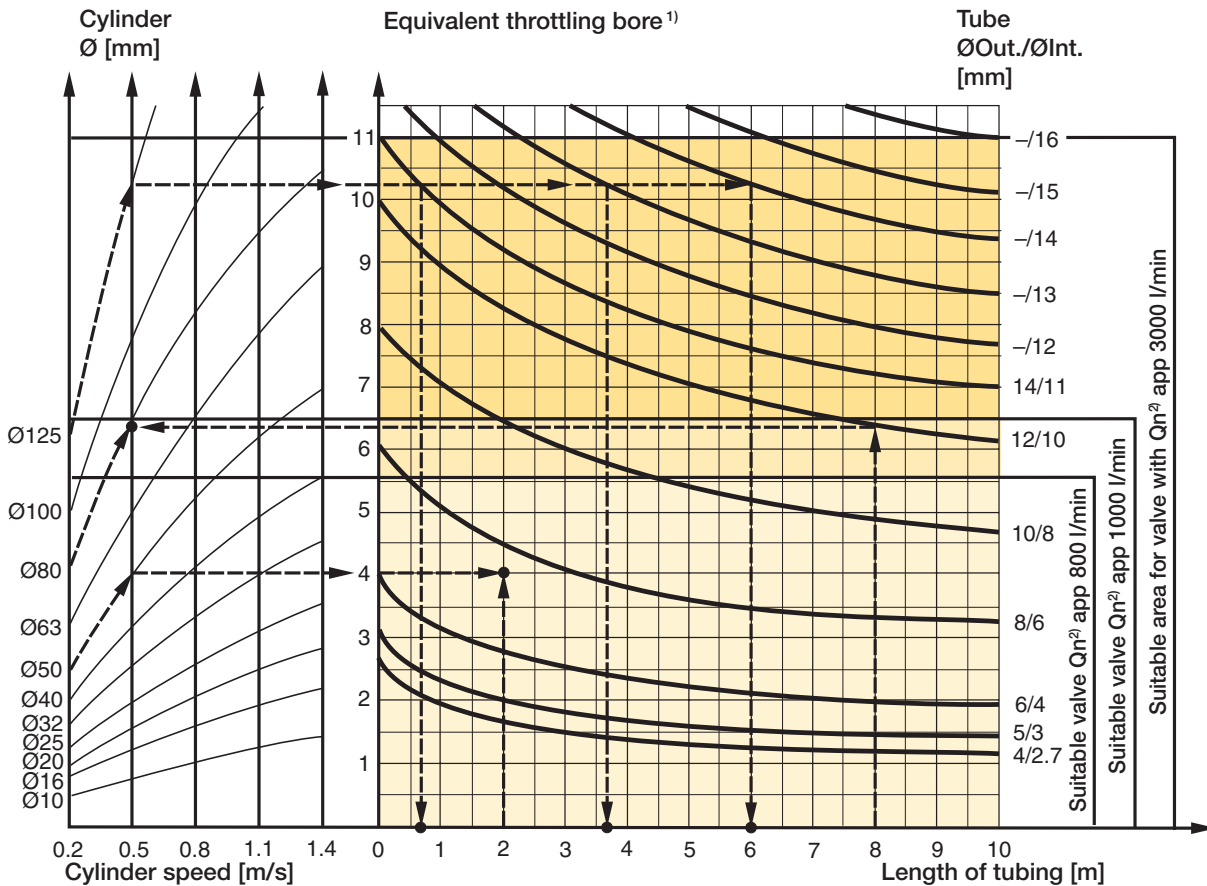

- 1) The "equivalent throttling bore" is a long throttle (for example a tube) or a series of throttles (for example, through a valve) converted to a short throttle which gives a corresponding flow rate. This should not be confused with the "orifice" which is sometimes specified for valves. The value for the orifice does not normally take account of the fact that the valve contains a number of throttles.
- 2) Qn is a measure of the valve flow capacity, with flow measured in liter per minute (l/min) at 6 bar(e) supply pressure and 1 bar pressure drop across the valve.

B
Tie Rod Pneumatic Cylinders
4MA Series
4MAJ Series
2MNR Series
ACVB Option
LPSO Option
P1D Series



For inventory, lead time, and kit lookup, visit www.pdnplu.com

P1D Rod Lock Version – Rod Lock Data

Connection

The signal air for the locking device can be obtained directly from a main air supply, or from the air supply serving the valve that controls the cylinder itself. For controlled ON/OFF operation of the locking device, a separate quick-venting valve is used.

The piston rod should not be moving when the locking device is activated. The locking device is not intended to brake a movement in repeated sequences.

Holding Forces*

Bore size	Holding forces	
	(N)	(lbs)
32mm	550	123
40mm	860	193
50mm	1345	303
63mm	2140	481
80mm	3450	755
100mm	5390	1211
125mm	8425	1894

NOTE: All P1D Rod Lock Versions are not intended for use in water service applications, or in environments that have high humidity levels and/or splashing fluids present.

* While cylinder is on extend at 87 PSI.

Use as a Brake

The chart to the right shows the maximum values for speed and braking mass if the cylinder is used as a brake. The cylinder should not be exposed to additional compressive forces as this significantly reduces the external mass that can be braked.

We recommend systems in which the cylinder does not act as a motor during braking. Heat is generated if the brake is used frequently, and this must be taken into account to ensure that the maximum temperature is not exceeded.

Sample Pneumatic Circuit

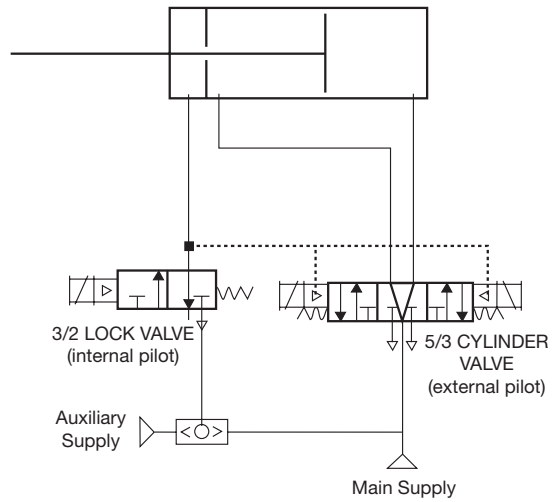

1. Lock valve must be maintained energized during cylinder motion, otherwise rod lock is engaged and cylinder valve shifts to mid position.
2. Cylinder valve must be maintained energized during extend or retract. Also keep energized at end of stroke until change of direction is desired.
3. Mid position of 5/3 Cylinder valve may be pressurized outlets if the combination of pressure load on the cylinder and inertia effects of the attached load do not exceed the holding force rating of the rod lock device, including allowance for wear.
4. Do not use cylinder lines for any logic functions — pressure levels vary too much.

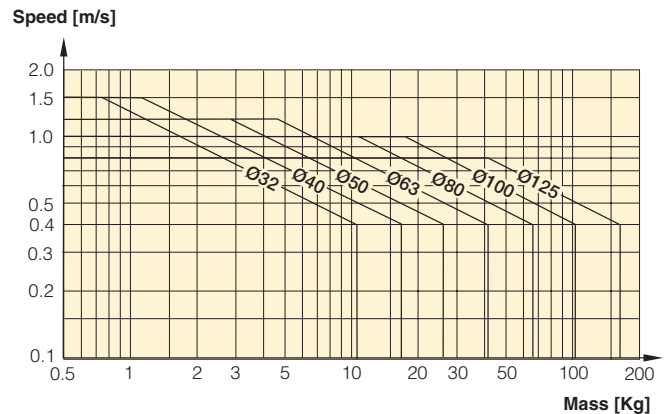

P1D Removable Gland Version

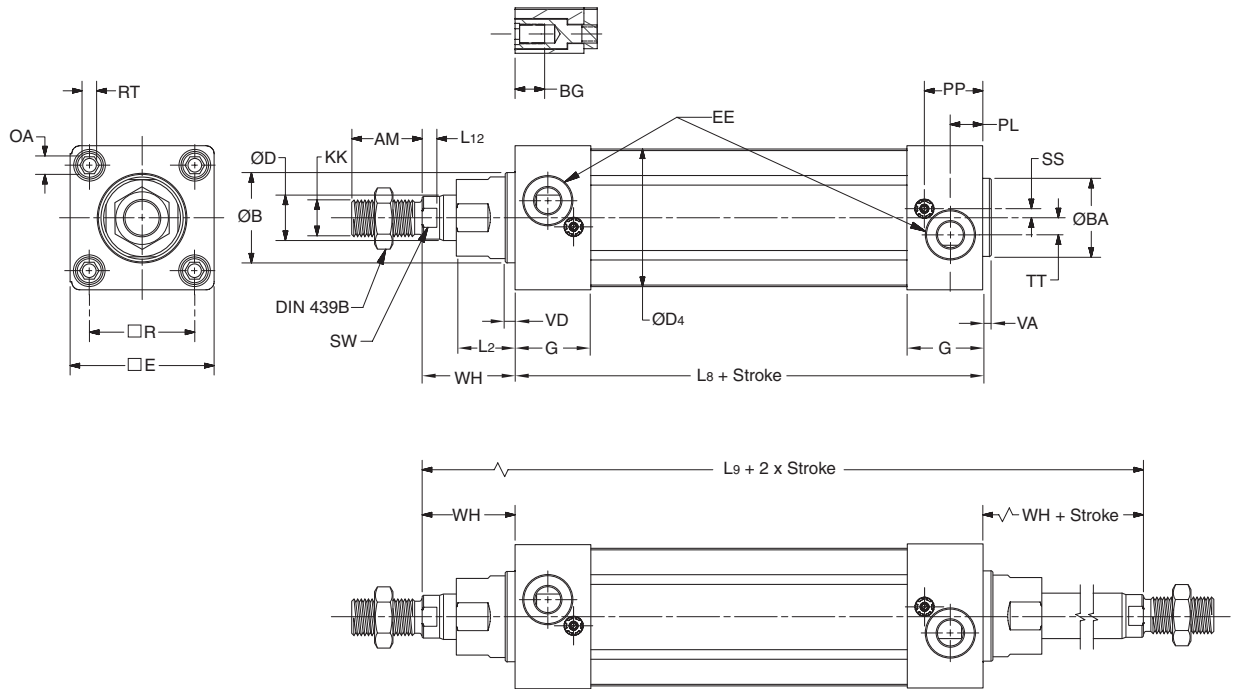

Removable Gland Version

Bore size	AM mm	B mm	BA mm	BG mm	D mm	D4 mm	E mm	EE		G mm	KK ²	L2 mm	L8 mm	L9 mm	L12 mm
								BSPP ¹	NPTF/BSPT						
32	22	30	30	16	12	45.0	46.5	G1/8	1/8	28.5	M10x1.25	18	94	146	6.0
40	24	35	35	16	16	52.0	52.0	G1/4	1/4	33.0	M12x1.25	20	105	165	6.5
50	32	40	40	16	20	60.7	63.5	G1/4	1/4	33.5	M16x1.5	26	106	180	6.5
63	32	45	45	16	20	71.5	76.0	G3/8	3/8	39.5	M16x1.5	26	121	195	6.5
80	40	45	45	17	25	86.7	95.5	G3/8	3/8	39.5	M20x1.5	33	128	220	10.0
100	40	55	55	17	25	106.7	114.5	G1/2	1/2	44.5	M20x1.5	33	138	240	10.0
125	54	60	60	20	32	134.0	140.0	G1/2	1/2	51.0	M27x2	41	160	290	13.0

Bore size	OA mm	PL mm	PP mm	R mm	RT	SS mm	SW mm	TT mm	VA mm	VD mm	WH mm
32	6	13	21.8	32.5	M6	6.5	10	4.5	3.5	4.5	26
40	6	14	21.9	38.0	M6	8.0	13	5.5	3.5	4.5	30
50	8	14	25.9	46.5	M8	4.0	17	7.5	3.5	4.5	37
63	8	16	27.4	56.5	M8	6.5	17	11.0	3.5	4.5	37
80	6	16	30.5	72.0	M10	0	22	15.0	3.5	4.5	46
100	6	18	35.8	89.0	M10	0	22	20.0	3.5	4.5	51
125	8	23	40.5	110.0	M12	0	27	17.5	5.5	6.5	65

1 ISO 1179-1 with ISO 228-1 threads
2 See Rod Ends and Special Threads

B
Tie Rod Pneumatic Cylinders

4MA Series
4MAJ Series
2MNR Series
ACVB Option
LPSO Option
P1D Series



For inventory, lead time, and kit lookup, visit www.pdnplu.com

Rod Lock Version R

P1D Rod Lock Version R

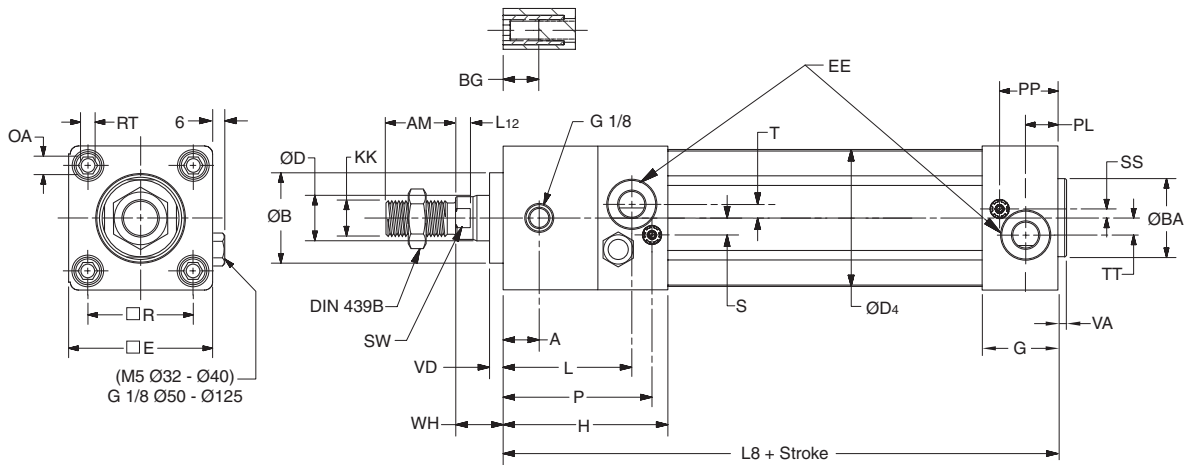

Rod Lock (Version R)

Bore size	A mm	AM mm	B mm	BA mm	BG mm	D mm	D4 mm	E mm	EE ¹	G mm	H mm	KK ²	L mm	L8 mm	L12 mm
32	16	22	30	30	16	12	45.0	46.5	G1/8	28.5	71.5	M10x1.25	56.0	137	6.0
40	16	24	35	35	16	16	52.0	52.0	G1/4	33.0	77.0	M12x1.25	56.0	149	6.5
50	18	32	40	40	16	20	60.7	63.5	G1/4	33.5	80.5	M16x1.5	62.5	153	6.5
63	26	32	45	45	16	20	71.5	76.0	G3/8	39.5	96.5	M16x1.5	74.5	178	6.5
80	35	40	45	45	17	25	86.7	95.5	G3/8	39.5	110.5	M20x1.5	87.0	199	10.0
100	50	40	55	55	17	25	106.7	114.5	G1/2	44.5	132.5	M20x1.5	106.0	226	10.0
125	60	54	60	60	20	32	134.0	140.0	G1/2	51.0	145.0	M27x2	117.0	254	13.0

Bore size	OA mm	P mm	PL mm	PP mm	R mm	RT mm	S mm	SS mm	SW mm	T mm	TT mm	VA mm	VD mm	WH mm
32	6	64.8	13	21.8	32.5	M6	7	6.5	10	2.5	4.5	3.5	4.5	15
40	6	68.0	14	21.9	38.0	M6	9	8.0	13	2.0	5.5	3.5	4.5	16
50	8	73.5	14	25.9	46.5	M8	8	4.0	17	4.0	7.5	3.5	5.0	17
63	8	89.5	16	27.4	56.5	M8	8	6.5	17	2.0	11.0	3.5	5.0	17
80	6	101.5	16	30.5	72.0	M10	9	0	22	5.0	15.0	3.5	4.0	20
100	6	123.5	18	35.8	89.0	M10	12	0	22	6.0	20.0	3.5	4.0	20
125	8	136.0	23	40.5	110.0	M12	12	0	27	6.0	17.5	5.5	6.0	27

1 ISO 1179-1 with ISO 228-1 threads
2 See Rod Ends and Special Threads

P Tie Rod Pneumatic Cylinders

Series 4MA, 4MAJ, 2MNR, ACVB, LPSO, P1D



For inventory, lead times, and kit lookup, visit www.pdnplu.com

P1D Rod Lock Version with Manual Override (Version J)

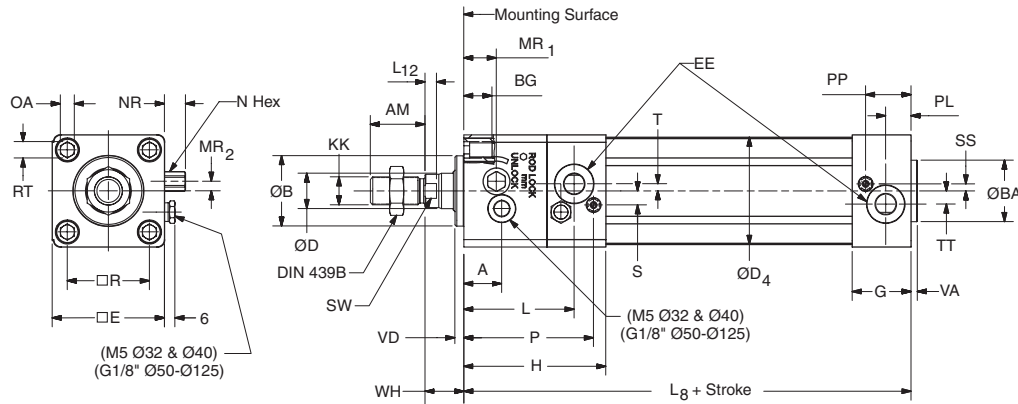

Rod Lock Version with Manual Override (Version J)

Bore size	A mm	AM mm	B mm	BA mm	BG mm	D mm	D4 mm	E mm	EE ¹	G mm	H mm	KK ²	L mm	L8 mm	L12 mm	MR1 mm	MR2 mm
32	27.0	22	30	30	16	12	45.0	46.5	G1/8	28.5	71.5	M10X1.25	56.0	137	6.0	16.0	3.0
40	27.0	24	35	35	16	16	52.0	52.0	G1/4	33.0	77.0	M12X1.25	56.0	149	6.5	16.0	3.0
50	21.5	32	40	40	16	20	60.7	63.5	G1/4	33.5	80.5	M16X1.5	62.5	153	6.5	18.5	5.5
63	39.0	32	45	45	16	20	71.5	76.0	G3/8	39.5	96.5	M16X1.5	74.5	178	6.5	22.0	4.0
80	48.5	40	45	45	17	25	86.7	95.5	G3/8	39.5	110.5	M20X1.5	87.0	199	10.0	15.0	19.8
100	65.0	40	55	55	17	25	106.7	114.5	G1/2	44.5	132.5	M20X1.5	106.0	226	10.0	15.0	20.8
125	71.0	54	60	60	20	32	134.0	140.0	G1/2	51.0	145.0	M27X2	117.0	254	13.0	19.0	23.0

Bore size	N mm	NR mm	OA mm	P mm	PL mm	PP mm	R mm	RT	S mm	SS mm	SW mm	T mm	TT mm	VA mm	VD mm	WH mm
32	8	10.0	6	64.8	13	21.8	32.5	M6	7	6.5	10	2.5	4.5	3.5	4.5	15
40	8	10.0	6	68.0	14	21.9	38.0	M6	9	8.0	13	2.0	5.5	3.5	4.5	16
50	10	12.0	8	73.5	14	25.9	46.5	M8	8	4.0	17	4.0	7.5	3.5	5.0	17
63	10	12.0	8	89.5	16	27.4	56.5	M8	8	6.5	17	2.0	11.0	3.5	5.0	17
80	11	12.5	6	101.5	16	30.5	72.0	M10	9	0	22	5.0	15.0	3.5	14.0	30
100	11	12.5	6	123.5	18	35.8	89.0	M10	12	0	22	6.0	20.0	3.5	14.0	30
125	11	12.5	8	136.0	23	40.5	110.0	M12	12	0	27	6.0	17.5	5.5	16.0	37

1 ISO 1179-1 with ISO 228-1 threads
 2 See Rod Ends and Special Threads

Tolerances

Bore size	B mm	R mm	L8 mm	BA mm	Stroke-length tolerance mm
32	d11	±0.5	±0.4	d11	+1/-0
40	d11	±0.5	±0.7	d11	+1/-0
50	d11	±0.6	±0.7	d11	+1/-0
63	d11	±0.7	±0.8	d11	+1/-0
80	d11	±0.7	±0.8	d11	+1/-0
100	d11	±0.7	±1.0	d11	+1/-0
125	d11	±1.1	±1.0	d11	+1/-0

B
 Tie Rod Pneumatic Cylinders
 4MA Series
 4MAJ Series
 2MNR Series
 ACVB Option
 LPSO Option
 P1D Series



For inventory, lead time, and kit lookup, visit www.pdnplu.com

P1D Tie-Rod Version (32-125mm)

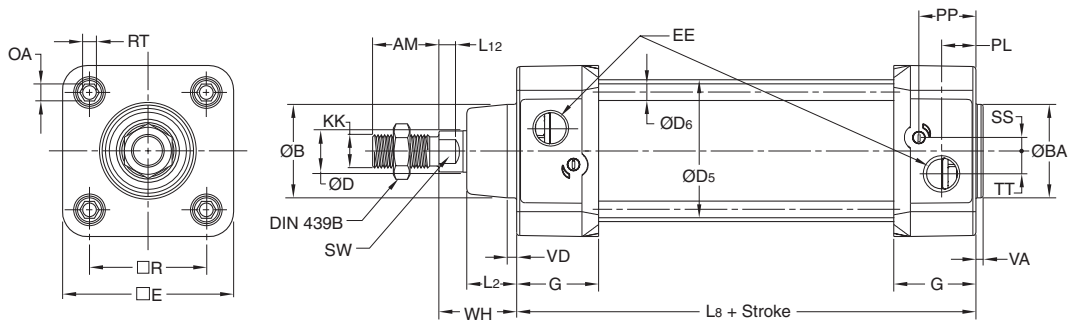

Tie-Rod (32-125mm)

Bore size	AM mm	B mm	BA mm	D mm	D5 mm	D6 mm	E	EE		G mm	KK ²	L2 mm	L8 mm
								BSP ¹	NPTF/BSPT				
32	22	30	30	12	36	5.3	50.0	G1/8	1/8	28.5	M10x1.25	16.0	94
40	24	35	35	16	45	5.3	57.4	G1/4	1/4	33.0	M12x1.25	19.0	105
50	32	40	40	20	55	7.1	69.4	G1/4	1/4	33.5	M16x1.5	24.0	106
63	32	45	45	20	68	7.1	82.4	G3/8	3/8	39.5	M16x1.5	24.0	121
80	40	45	45	25	85	8.9	99.4	G3/8	3/8	39.5	M20x1.5	30.0	128
100	40	55	55	25	105	8.9	116.0	G1/2	1/2	44.5	M20x1.5	32.4	138
125	54	60	60	32	132	10.7	139.0	G1/2	1/2	51.0	M27x2	45.0	160

Bore size	L12 mm	OA mm	PL mm	PP mm	R mm	RT	SS mm	SW mm	TT mm	VA mm	VD mm	WH mm
32	6.0	6	13	21.8	32.5	M6	4.0	10	4.5	3.5	4.5	26
40	6.5	6	14	21.9	38.0	M6	8.0	13	5.5	3.5	4.5	30
50	8.0	8	14	25.9	46.5	M8	4.0	17	7.5	3.5	4.5	37
63	8.0	8	16	27.4	56.5	M8	6.5	17	11.0	3.5	4.5	37
80	10.0	6	16	30.5	72.0	M10	0	22	15.0	3.5	4.5	46
100	10.0	6	18	35.8	89.0	M10	0	22	20.0	3.5	4.5	51
125	13.0	8	23	40.5	110.0	M12	0	27	17.5	3.5	6.5	65

1 ISO 1179-1 with ISO 228-1 threads
2 See Rod Ends and Special Threads

B
 Tie Rod Pneumatic Cylinders
 Series
 4MA
 Series
 4MAJ
 Series
 2MNR
 Option
 ACVB
 Option
 LPSO
 Series
 P1D



For inventory, lead times, and kit lookup, visit www.pdnplu.com

B116

Parker Hannifin Corporation
Pneumatic Division
Richland, Michigan
www.parker.com/pneumatics

P1D Tie-Rod Version (160-200mm)

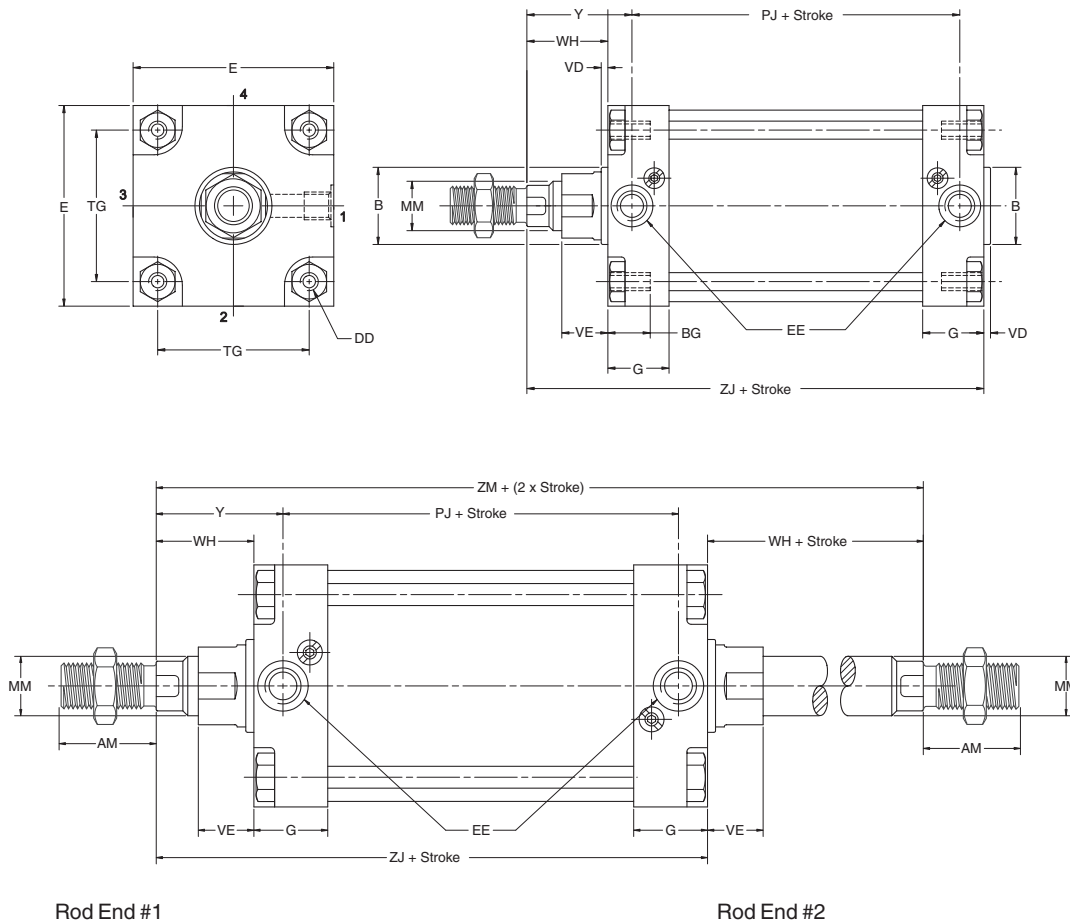

P1D Tie-Rod Version (160-200mm)

Bore size	AM mm	B d11 mm	BG mm	DD	E mm	EE		G mm	MM mm	TG mm	VD mm	VE mm	WH mm	Y mm	PJ1 mm	ZJ1 mm	ZM2 mm
						BSPP ³	NPTF/BSPT										
160	72	65	24	M16	177	G3/4	3/4	54	40	140	6	56	80	105	130	260	340
200	72	75	24	M16	214	G3/4	3/4	54	40	175	6	56	95	120	130	275	370

¹ Add stroke
² Add 2x stroke
³ ISO 1179-1 with ISO 228-1 threads

Double Rod Cylinders

Double rod option is available on Mounting Styles MX0, MS1, MF1, MF2 and MT4.

For double rod cylinders, it is assumed that the rod number and rod end are the same for both piston rods. On a double rod cylinder where the two rod ends are different, use a rod end of '3' and be sure to clearly state which rod end is to be assembled at which end.

B
Tie Rod Pneumatic Cylinders
4MA Series
4MAJ Series
2MNR Series
ACVB Option
LPSO Option
P1D Series



For inventory, lead time, and kit lookup, visit www.pdnplu.com

All Mountings Except MF1

Thread Style N

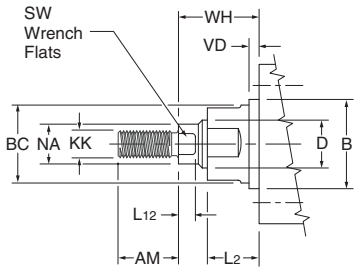

Thread Style 6

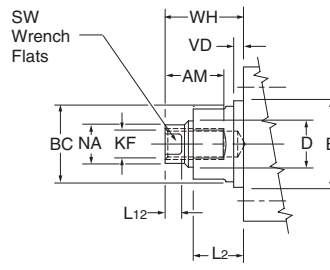

Thread Style 3 - "Special Thread"

Special thread, extension, rod eye, blank, etc are also available. To order, specify "Style 3" and provide desired dimensions for KF or KK, AM and WH. If otherwise special, furnish dimensioned sketch.

Bore size	D	KK	KF	AM	B d11	BC	SW across flats	L12	NA	VD	L2	WH*
32	12	M10x1.25	M8x1	22	30	27	10	6	11	4.5	18	26
40	16	M12x1.25	M10x1.25	24	35	32	13	6.5	15	4.5	20	30
50	20	M16x1.5	M14x1.5	32	40	36	17	6.5	19	4.5	26	37
63	20	M16x1.5	M14x1.5	32	45	36	17	6.5	19	4.5	26	37
80	25	M20x1.5	M18x1.5	40	45	41	22	10	24	4.5	33	46
100	25	M20x1.5	M18x1.5	40	55	41	22	10	24	4.5	33	51
125	32	M27x2	M24x2	54	60	50	27	13	31	6.5	41	65
160	40	M36x2	M30x2	72	65	60	36	16	39	6	56	80
200	40	M36x2	M30x2	72	75	60	36	16	39	6	56	95

*NOTE: Dimensions do not apply to Rod Lock Versions.

With MF1 Mounting

Thread Style N

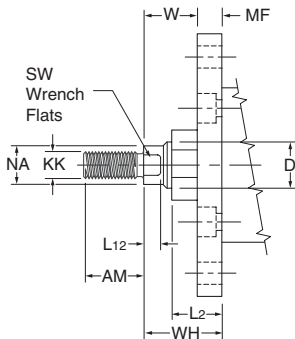

Thread Style 6

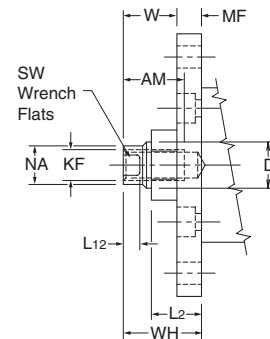

"Special Thread" Style 3

Special thread, extension, rod eye, blank, etc are also available. To order, specify "Style 3" and provide desired dimensions for KF or KK, AM and WH. If otherwise special, furnish dimensioned sketch.

Bore size	D	KK	KF	AM	SW across flats	L12	MF	NA	L2	W†	WH†
32	12	M10x1.25	M8x1	22	10	6	10	11	18	16	26
40	16	M12x1.25	M10x1.25	24	13	6.5	10	15	20	20	30
50	20	M16x1.5	M14x1.5	32	17	6.5	12	19	26	25	37
63	20	M16x1.5	M14x1.5	32	17	6.5	12	19	26	25	37
80	25	M20x1.5	M18x1.5	40	22	10	16	24	33	30	46
100	25	M20x1.5	M18x1.5	40	22	10	16	24	33	35	51
125	32	M27x2	M24x2	54	27	13	20	31	41	45	65
160	40	M36x2	M30x2	72	36	16	20	39	56	60	80
200	40	M36x2	M30x2	72	36	16	25	39	56	70	95

†NOTE: Dimensions do not apply to Rod Lock Versions.



For inventory, lead times, and kit lookup, visit www.pdnplu.com

Duplex & Tandem Cylinders

3 and 4-Position Duplex Cylinders

This type of cylinder function can consist of two cylinders installed back to back. Two cylinders with the same stroke result in a 3-position cylinder with a symmetrical center position, whereas two different strokes result in a 4-position cylinder where the two central positions can be calculated from the different stroke lengths.

A 3-position duplex cylinder can also be obtained by mounting two cylinders of different strokes, in series, but not connecting the piston rods together.

These 3 and 4-position cylinders can be ordered in two ways as follows.

Factory-fitted P1D Duplex Cylinders

P1D tie-rod version duplex cylinders are completed at the factory and are joined together as one unit by special tie-rods. This version needs to be ordered as a special (/). Please consult factory for assistance.

Customer-Installed Mounting Kit

There is an installation mounting kit available for cylinder bores 32-100mm which makes it possible to join any two P1D cylinders, of the same bore, together at any time to make a 3 or 4-position cylinder. Please refer to the cylinder mountings on top of page B124.

Tandem Cylinders

In addition to the duplex cylinder options above, the P1D tie-rod version is also available as a tandem cylinder. By ordering two cylinders of equal strokes, mounted in series, and connecting the piston rods together, you achieve almost twice the output force, at the same pressure, as a standard cylinder. This is a great advantage when restricted mounting space prevents the use of a larger bore cylinder. Please review version and function options in the model code on page B107.

Cylinder Bore	A (mm)
	P1D-T
32	247
40	277
50	293
63	323
80	355
100	385
125	461

S = Stroke

B

Tie Rod Pneumatic Cylinders

4MA Series

4MAJ Series

2MNR Series

ACVB Option

LPSO Option

P1D Series



For inventory, lead time, and kit lookup, visit www.pdnplu.com

Accessories

Flange - MF1 / MF2



Intended for fixed mounting of cylinder. Flange can be fitted to front or rear end cover of cylinder.

Materials:

Flange: Surface-treated steel
Mounting screws acc. to DIN 6912:
Zinc-plated steel 8.8

Supplied complete with mounting screws for attachment to the cylinder.

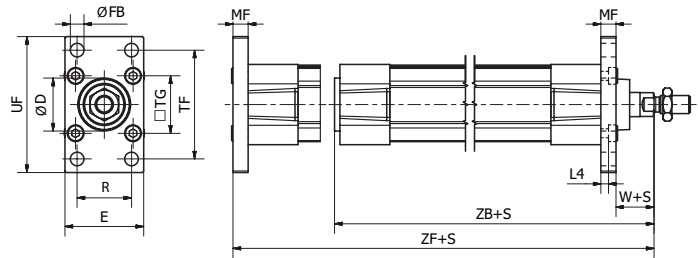

According to ISO 15552

Bore size mm	D (H11) mm	E mm	ØFB (H13) mm	L4 mm	MF mm	R mm	TF mm	TG mm	UF mm	W* mm	ZB* mm	ZF* mm	Weight kg	Part number
32	30	45	7	5.0	10	32	64	32.5	80	16	123.5	130	0.21	P1C-4KMB
40	35	52	9	5.0	10	36	72	38.0	90	20	138.5	145	0.27	P1C-4LMB
50	40	65	9	6.5	12	45	90	46.5	110	25	146.5	155	0.53	P1C-4MMB
63	45	75	9	6.5	12	50	100	56.5	120	25	161.5	170	0.66	P1C-4NMB
80	45	95	12	9.0	16	63	126	72.0	150	30	177.5	190	1.45	P1C-4PMB
100	55	115	14	9.0	16	75	150	89.0	170	35	192.5	205	1.60	P1C-4QMB
125	60	140	16	10.5	20	90	180	110.0	205	45	230.5	245	3.34	P1C-4RMB
160	65	180	18	9.5	20	115	230	140.0	279	60	266	280	7.2	P1C-4SMB
200	75	220	22	12.5	25	135	270	175.0	300	70	281	300	C.F.	P1C-4TMB

*Does not apply to cylinders with piston rod extension or lock units.

Foot Bracket - MS1



Intended for fixed mounting of cylinder. Foot bracket can be fitted to front or rear end cover of the cylinder.

Materials:

Flange: Surface-treated steel
Mounting screws acc. to DIN 6912:
Zinc-plated steel 8.8:

Supplied complete with mounting screws for attachment to the cylinder.

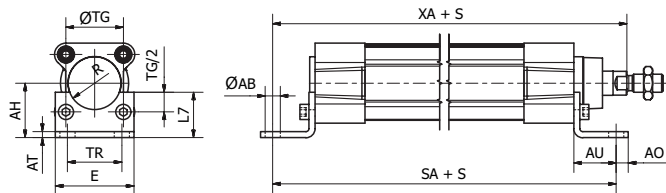

According to ISO 15552

Bore size mm	ØAB (H14) mm	AH (JS15) mm	AO mm	AT mm	AU mm	E mm	L7 mm	R mm	SA* mm	TG mm	TR (JS14) mm	XA* mm	Weight ** kg	Part number
32	7.0	32	11	4	24	45	30	15.0	142	32.5	32	144	0.08	P1C-4KMF
40	10.0	36	8	4	28	52	30	17.5	161	38.0	36	163	0.09	P1C-4LMF
50	10.0	45	15	5	32	65	36	20.0	170	46.5	45	175	0.18	P1C-4MMF
63	10.0	50	13	5	32	75	35	22.5	185	56.5	50	190	0.20	P1C-4NMF
80	12.0	63	14	6	41	95	47	22.5	210	72.0	63	215	0.40	P1C-4PMF
100	14.5	71	16	6	41	115	53	27.5	220	89.0	75	230	0.54	P1C-4QMF
125	16.5	90	25	8	45	140	70	30.0	250	110.0	90	270	1.10	P1C-4RMF
160	18	115	15	9	60	180	100	-	300	140.0	115	-	C.F.	P1C-4SMF
200	22	135	30	12	70	220	100	-	320	175.0	135	-	C.F.	P1C-4TMF

*Does not apply to cylinders with piston rod extension or lock units.

** per bracket



For inventory, lead times, and kit lookup, visit www.pdnplu.com

Pivot Bracket with Rigid Bearing - AB7



Intended for flexible mounting of cylinder. The pivot bracket can be combined with clevis bracket MP2.

Materials:
Pivot bracket: Aluminium
(Bush: Steel and PTFE)

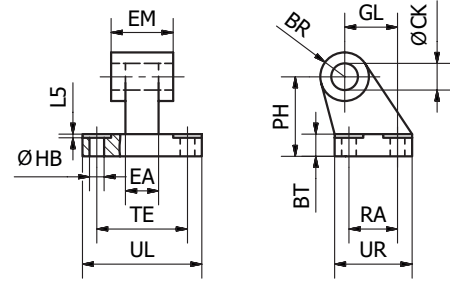

According to ISO 15552

Bore size mm	CK mm	HB mm	L5 mm	TE mm	UL mm	GL mm	RA mm	EA mm	EM mm	UR mm	PH mm	BT mm	BR mm	Weight kg	Part number
32	10	6.6	1.6	38	51	21	18	10	26	31	32	8	10.0	0.05	P1C-4KMDB
40	12	6.6	1.6	41	54	24	22	15	28	35	36	10	11.0	0.09	P1C-4LMDB
50	12	9.0	1.6	50	65	33	30	16	32	45	45	12	13.0	0.16	P1C-4MMDB
63	16	9.0	1.6	52	67	37	35	16	40	50	50	14	15.0	0.20	P1C-4NMDB
80	16	11.0	2.5	66	86	47	40	20	50	60	63	14	15.0	0.32	P1C-4PMDB
100	20	11.0	2.5	76	96	55	50	20	60	70	71	17	19.0	0.53	P1C-4QMDB
125	25	14.0	3.2	94	124	70	60	30	70	90	90	20	22.5	1.01	P1C-4RMDB
160	30	-	-	118	156	97	89	-	88.5	126	115	25	31.0	C.F.	P1C-4SMDB
200	30	-	-	122	162	105	89	-	88.5	130	135	30	31.0	C.F.	P1C-4TMDB

Swivel Eye Bracket - MP6

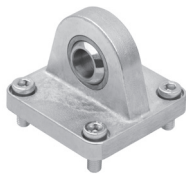

Intended for use together with clevis bracket AB6.

Materials:
Bracket: Aluminium
Swivel bearing acc. to DIN 648K:
Hardened steel

Supplied complete with mounting screws for attachment to cylinder.

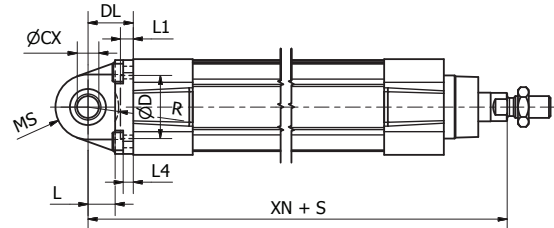
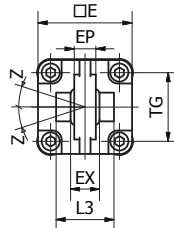

According to ISO 15552

Bore size mm	CX mm	D mm	DL mm	E mm	EP mm	EX mm	L mm	L1 mm	L3 mm	L4 mm	MS mm	R mm	TG mm	XN* mm	Z mm	Weight kg	Part number
32	10	30	22	45	10.5	14	12	7	-	5.5	16	-	32.5	142	4°	0.09	P1C-4KMSB
40	12	35	25	52	12	16	15	7	-	5.5	18	-	38	160	4°	0.13	P1C-4LMSB
50	16	40	27	65	15	21	15	7	51	6.5	21	19	46.5	170	4°	0.24	P1C-4MMSB
63	16	45	32	75	15	21	20	7	-	6.5	23	-	56.5	190	4°	0.29	P1C-4NMSB
80	20	45	36	95	18	25	20	9	74	10	28	24	72	210	4°	0.59	P1C-4PMSB
100	20	55	41	115	18	25	25	9	140	10	30	32	89	230	4°	0.78	P1C-4QMSB
125	30	60	50	140	25	37	30	9	-	10	40	-	110	275	4°	1.38	P1C-4RMSB
160	35	-	55	177	30	43	41	4	-	-	44	41	-	315	16°	C.F.	P1C-4SMSB
200	35	-	60	214	30	43	42	8	-	-	48	42	-	335	16°	C.F.	P1C-4TMSB

*Does not apply to cylinders with piston rod extension or lock units.



For inventory, lead time, and kit lookup, visit www.pdnplu.com

Accessories

Clevis Bracket - MP2

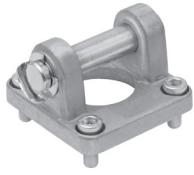

Intended for flexible mounting of cylinder. Can be combined with clevis bracket MP4 and pivot bracket with rigid bearing AB7.

Materials:

- Clevis bracket: Aluminium
- Pin: Surface hardened steel
- Locking pin: Spring steel
- Circlips according to DIN 471: Spring steel
- Mounting screws acc. to DIN 912: Zinc-plated steel 8.8

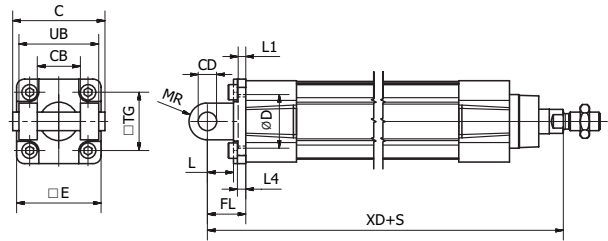

Supplied complete with mounting screws for attachment to the cylinder.

According to ISO 15552

Bore size mm	C mm	E mm	UB mm	CB mm	TG mm	FL mm	L1 mm	L mm	L4 mm	D mm	CD mm	MR mm	XD* mm	Weight kg	Part number
32	53	45	45	26	32.5	22	5	13	5.5	30	10	10	142	0.08	P1C-4KMTB
40	60	52	52	28	38	25	5	16	5.5	35	12	12	160	0.10	P1C-4LMTB
50	68	65	60	32	46.5	27	5	16	6.5	40	12	12	170	0.18	P1C-4MMTB
63	78	75	70	40	56.5	32	5	21	6.5	45	16	16	190	0.24	P1C-4NMTB
80	98	95	90	50	72	36	5	22	10	45	16	16	210	0.49	P1C-4PMTB
100	118	115	110	60	89	41	5	27	10	55	20	20	230	0.73	P1C-4QMTB
125	139	140	130	70	110	50	7	30	10	60	25	25	275	1.37	P1C-4RMTB
160	180	C.F.	170	90	C.F.	55	C.F.	35	C.F.	C.F.	30	25	315	2.20	P1C-4SMTB
200	220	C.F.	170	90	C.F.	60	C.F.	35	C.F.	C.F.	30	25	335	3.47	P1C-4TMTB

*Does not apply to cylinders with piston rod extension or lock units.

Clevis Bracket - MP4



Intended for flexible mounting of cylinder. Clevis bracket MP4 can be combined with clevis bracket MP2.

Materials:

- Clevis bracket: Aluminium
- Bush: Steel and PTFE
- Mounting screws acc. to DIN 912: Zinc-plated steel 8.8

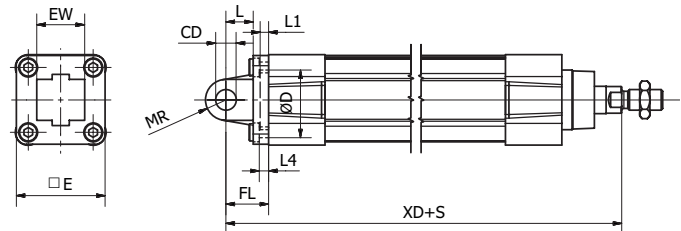

Supplied complete with mounting screws for attachment to the cylinder.

According to ISO 15552

Bore size mm	CD mm	D mm	E mm	EW mm	FL mm	L mm	L1 mm	L4 mm	MR mm	XD* mm	Weight kg	Part number
32	10	30	47	26	22	12	6.5	6	10.5	142	0.08	P1C-4KMEB
40	12	35	52	28	25	16	5	5.5	12	160	0.11	P1C-4LMEB
50	12	40	65	32	27	16	5	6.5	12	170	0.18	P1C-4MMEB
63	16	45	78	40	32	21	5	6.5	16	190	0.28	P1C-4NMEB
80	16	45	95	50	36	22	5	10	16	210	0.52	P1C-4PMEB
100	20	55	115	60	41	27	5	10	20	230	0.79	P1C-4QMEB
125	25	60	140	70	50	30	7	10	25	275	1.46	P1C-4RMEB
160	30	-	180	90	55	35	-	10	25	315	C.F.	P1C-4SMEB
200	30	-	220	90	60	35	-	14	25	335	C.F.	P1C-4TMEB

*Does not apply to cylinders with piston rod extension or lock units.



For inventory, lead times, and kit lookup, visit www.pdnplu.com

Accessories

Clevis Bracket – AB6

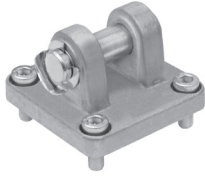

Intended for flexible mounting of cylinder. Clevis bracket AB6 can be combined with pivot brackets MP6 and CS7 or swivel rod eye AP6.

Materials:

- Clevis bracket: Aluminium
- Pin: Surface hardened steel
- Locking pin: Spring steel
- Circlips according to DIN 471: Spring steel
- Mounting screws acc. to DIN 912: Zinc-plated steel 8.8
- Supplied complete with mounting screws for attachment to the cylinder.

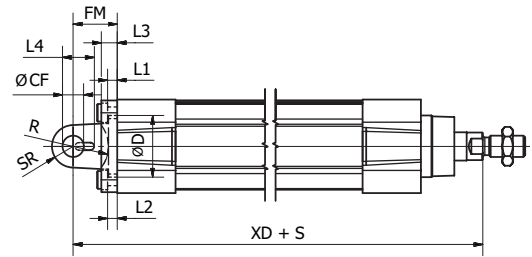
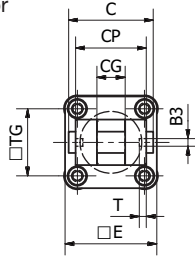

According to ISO 15552

Bore size mm	B3 mm	C mm	CF mm	CG mm	CP mm	D mm	E mm	FM mm	I2 mm	T mm	R mm	L1 mm	L4 mm	L3 mm	SR mm	TG mm	XD* mm	Weight kg	Part number
32	3.3	41	10	14	34	30	45	22	5.5	3	17	5	16.5	9	10	32.5	142	0.04	P1C-4KMCB
40	4.3	48	12	16	40	35	52	25	5.5	4	20	5	18	9	12	38	160	0.07	P1C-4LMCB
50	4.3	54	16	21	45	40	65	27	6.5	4	22	5	22	11	14	46.5	170	0.11	P1C-4MNCB
63	4.3	60	16	21	51	45	75	32	6.5	4	25	5	22	11	18	56.5	190	0.19	P1C-4NMCB
80	4.3	75	20	25	65	45	95	36	10.0	4	30	5	26	14	20	72	210	0.38	P1C-4PMCB
100	6.3	85	20	25	75	55	115	41	10.0	4	32	5	26	14	22	89	230	0.61	P1C-4QMCB
125	6.3	110	30	37	97	60	140	50	10.0	6	42	7	39	20	25	110	275	1.10	P1C-4RMCB

*Does not apply to cylinders with piston rod extension or lock units.

Head Detachable Clevis – MP7

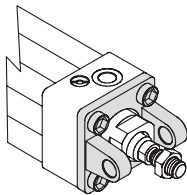

Intended for flexible mounting of cylinder

Materials:

- Clevis bracket: Cast iron for 32-63mm bores; Surface treated aluminum, black for 80-200mm bores
- Mounting screws acc. to DIN 912: Zinc-plated steel 8.8
- Supplied complete with mounting screws for attachment to cylinder.

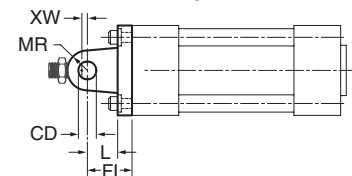
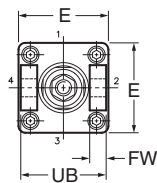

According to ISO MP7, VDMA 24 562, AFNOR

Bore size mm	CD mm	E mm	FL mm	FW mm	L mm	MR mm	UB mm	XW mm	Part number
32	10	46.5	22	8	12	10	45	4	L075400032
50	12	63.5	27	10	15	13	60	10	L075400050
63	16	76	32	15	20	16	70	5	L075400063
125	25	140	50	30	35	25	130	15	L075400125
160	30	177	55	40	36	30	170	25	L075400160

B

Tie Rod Pneumatic Cylinders

4MA Series

4MAJ Series

2MNR Series

ACVB Option

LPSO Option

P1D Series



For inventory, lead time, and kit lookup, visit www.pdnplu.com

Accessories

Pivot Bracket with Swivel Bearing, CS7



Intended for use together with clevis bracket AB6.

Materials:
Pivot bracket: Aluminium
Swivel bearing acc. to DIN 648K:
Hardened steel

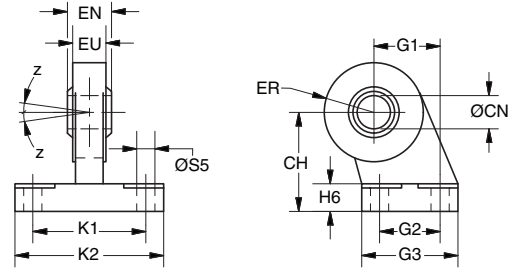

According to ISO 15552

Bore size mm	CN mm	S5 mm	K1 mm	K2 mm	EU mm	G1 mm	G2 mm	EN mm	G3 mm	CH mm	H6 mm	ER mm	Z mm	Weight kg	Part number
32	10	6.6	38	51	10.5	21	18	14	31	32	10	15	4°	0.18	P1C-4KMAF
40	12	6.6	41	54	12.0	24	22	16	35	36	10	18	4°	0.27	P1C-4LMAF
50	16	9.0	50	65	15.0	33	30	21	45	45	12	20	4°	0.46	P1C-4MMAF
63	16	9.0	52	67	15.0	37	35	21	50	50	12	23	4°	0.55	P1C-4NMAF
80	20	11.0	66	86	18.0	47	40	25	60	63	14	27	4°	0.97	P1C-4PMAF
100	20	11.0	76	96	18.0	55	50	25	70	71	15	30	4°	1.33	P1C-4QMAF
125	30	13.5	94	124	25.0	70	60	37	90	90	20	40	4°	3.00	P1C-4RMAF

Mounting Kit

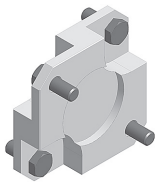

Mounting kit for back to back mounted cylinders, 3 and 4 position duplex cylinders.

Materials:
Mounting: Aluminium
Mounting screws: Zinc-plated steel 8.8

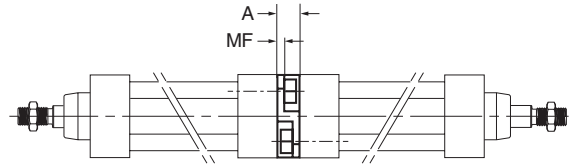

Bore size mm	E mm	TG mm	ØFB mm	MF mm	A mm	ØBA mm	Weight kg	Part number
32	50	32.5	6.5	5	16	30	0.060	P1E-6KB0
40	60	38.0	6.5	5	16	35	0.078	P1E-6LB0
50	66	46.5	8.5	6	20	40	0.162	P1E-6MB0
63	80	56.5	8.5	6	20	45	0.194	P1E-6NB0
80	100	72.0	10.5	8	25	45	0.450	P1E-6PB0
100	118	89.0	10.5	8	25	55	0.672	P1E-6QB0

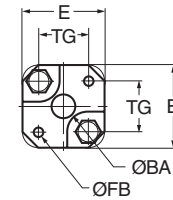

Pivot Bracket - MT4

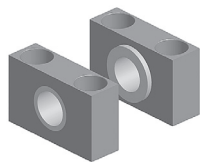

Intended for use together with central trunnion MT4.

Materials:
Pivot bracket: Surface-treated aluminium
Bearing acc. to DIN 1850 C: Sintered oil-bronze bushing
Supplied in pairs.

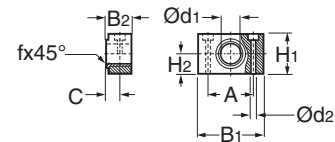

According to ISO, VDMA 24 562, AFNOR

Bore size mm	B1 mm	B2 mm	A mm	C mm	d1 mm	d2 H13 mm	H1 mm	H2 mm	fx45° min mm	Weight* kg	Part number
32	46	18.0	32	10.5	12	6.6	30	15	1.0	0.04	9301054261
40	55	21.0	36	12.0	16	9.0	36	18	1.6	0.07	9301054262
50	55	21.0	36	12.0	16	9.0	36	18	1.6	0.07	9301054263
63	65	23.0	42	13.0	20	11.0	40	20	1.6	0.12	9301054264
80	65	23.0	42	13.0	20	11.0	40	20	1.6	0.12	9301054265
100	75	28.5	50	16.0	25	14.0	50	25	2.0	0.21	9301054266
125	75	28.5	50	16.0	25	14.0	50	25	2.0	0.21	9301054267

* Weight per item



For inventory, lead times, and kit lookup, visit www.pdnplu.com

Intermediate Trunnion – MT4

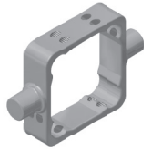

Standard

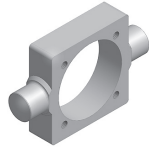

Tie Rod Version

Intended for articulated mounting of cylinder. The trunnion is factory-fitted at an optional location. Order by specifying Mounting Style G or 7 and providing the desired XV dimension (3-digit measure in mm). See page B97 for ordering information. Combined with pivot bracket for MT4 for 32-125mm bores.

Materials:
 Trunnion: Zinc plated steel
 (Cast iron for 160-200mm bores)

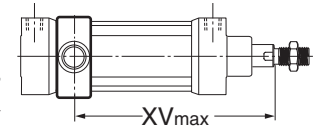
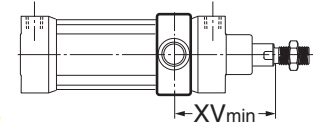
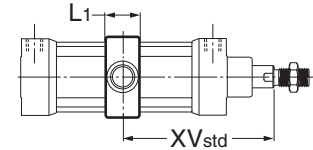
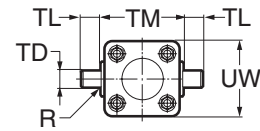

XV Standard for Rod Lock version:

$$\frac{L8 + \text{Stroke} + WH}{2}$$

According to ISO MT4, VDMA 24 562, AFNOR

Bore size mm	TM h14 mm	TL h14 mm	TD e9 mm	R mm	UW mm	L1 P1D-G mm	L1 P1D-E mm	X1 mm	Standard "G"		Standard "7"		Tie Rod		Weight kg
									XVmin mm	X2 mm	XVmin mm	X2 mm	XVmin mm	X2 mm	
32	50	12	12	1.0	46	18	15	73.0	84.0	76.0	94.0	62.0	84.0	0.13	
40	63	16	16	1.6	59	20	20	82.5	91.0	82.0	103.0	74.0	92.0	0.31	
50	75	16	16	1.6	69	20	20	90.0	108.5	89.5	107.5	71.5	80.5	0.37	
63	90	20	20	1.6	84	26	25	97.5	111.0	93.5	126.0	84.0	89.5	0.69	
80	110	20	20	1.6	102	26	25	110.0	125.0	109.5	143.0	95.0	98.0	0.89	
100	132	25	25	2.0	125	32	30	120.0	132.5	114.5	167.5	107.5	110.5	1.58	
125	160	25	25	2.0	155	33	32	145.0	160.0	142.0	188.0	130.0	132.0	2.60	
160	200	32	32	2.5	190	-	70	170.0	154.0	186.0	-	-	169	C.F.	
200	250	32	32	2.5	242	-	70	185.0	169.0	201.0	-	-	184	C.F.	

XVstd = X1 + Stroke length/2 XVmax = X2 + Stroke length C.F. = Consult Factory

Flange Mounted Trunnion, J or H

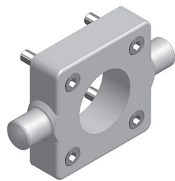

Intended for articulated mounting of cylinder. This trunnion can be flange mounted on the front or rear end cover of all P1D cylinders. If you choose, you can order a complete cylinder with factory-fitted flange mounted trunnion – see the ordering information on page B67 Individual trunnions have part numbers as shown below.

Materials:
 Trunnion: zinc plated steel
 Screws: zinc plated steel, 8.8

Delivered complete with mounting screws for attachment to the cylinder

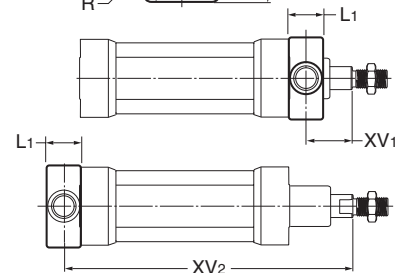
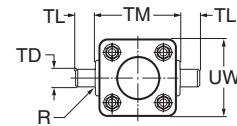

According to ISO MT4, VDMA 24 562, AFNOR

Bore size mm	TM h14 mm	TL h14 mm	TD e9 mm	R mm	UW mm	L1 mm	XV ₁ mm	X mm	Weight kg	Part number
32	50	12	12	1.0	46	14	19.0	127.0	0.17	P1D-4KMYF
40	63	16	16	1.6	59	19	20.5	144.5	0.43	P1D-4LMYF
50	75	16	16	1.6	69	19	27.5	152.5	0.55	P1D-4MMYF
63	90	20	20	1.6	84	24	25.0	170.0	1.10	P1D-4NMYF
80	110	20	20	1.6	102	24	34.0	186.0	1.66	P1D-4PMYF
100	132	25	25	2.0	125	29	36.5	203.5	3.00	P1D-4QMYF

XV₂ = X + Stroke length

B
 Tie Rod Pneumatic Cylinders
 4MA Series
 4MAJ Series
 2MNR Series
 ACVB Option
 LPSO Option
 P1D Series



For inventory, lead time, and kit lookup, visit www.pdnplu.com

Swivel Rod Eye



Stainless Steel Swivel Rod Eye

Swivel rod eye for articulated mounting of cylinder.
Swivel rod eye can be combined with clevis bracket GA.
Maintenance-free.

Materials:

Swivel rod eye: Zinc-plated steel
Swivel bearing according to DIN 648K: Hardened steel

Swivel rod eye: Stainless steel 304
Swivel bearing according to DIN 648K: Stainless steel

Use stainless steel nut (see next page) with stainless steel swivel rod eye.

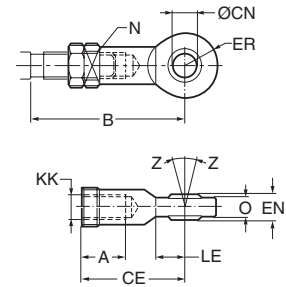

According to ISO 8139

Bore size mm	A mm	B min mm	B max mm	CE mm	CN H9 mm	EN h12 mm	ER mm	KK	LE min mm	N mm	O mm	Z	Weight kg	Part number	Stainless steel part number
32	20	48.0	55	43	10	14	14	M10x1.25	15	17	10.5	12°	0.08	P1C-4KRS	P1S-4JRT
40	22	56.0	62	50	12	16	16	M12x1.25	17	19	12.0	12°	0.12	P1C-4LRS	P1S-4LRT
50	28	72.0	80	64	16	21	21	M16x1.5	22	22	15.0	15°	0.25	P1C-4MRS	P1S-4MRT
63	28	72.0	80	64	16	21	21	M16x1.5	22	22	15.0	15°	0.25	P1C-4PRS	P1S-4PRT
80	33	87.0	97	77	20	25	25	M20x1.5	26	32	18.0	15°	0.46	P1C-4RRS	P1S-4RRT
100	33	87.0	97	77	20	25	25	M20x1.5	26	32	18.0	15°	0.46	P1C-4SRS	—
125	51	123.5	137	110	30	37	35	M27x2	36	41	25.0	15°	1.28	P1C-4RRS	P1S-4RRT
160/200	56	C.F.	C.F.	125	35*	43	40	M36x2	40	50	28.0	15°	C.F.	P1C-4SRS	—

*H7 C.F. = Consult Factory

Clevis

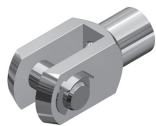

Stainless Steel Clevis

Clevis for articulated mounting of cylinder.

Materials:

Clevis, clip: Galvanized steel
Pin: Hardened steel

Clevis: Stainless steel
Pin: Stainless steel
Circlips according to DIN 471: Stainless steel

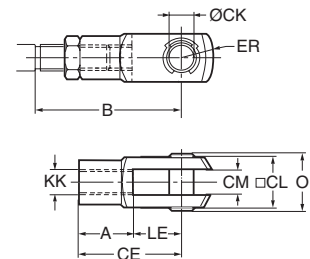

According to ISO 8140

Bore size mm	A mm	B min mm	B max mm	CE mm	CK h11/E9 mm	CL mm	CM mm	ER mm	KK	LE mm	O mm	Weight kg	Part number	Stainless steel part number
32	20	45.0	52	40	10	20	10	16	M10x1.25	20	28.0	0.09	P1C-4KRC	P1S-4JRD
40	24	54.0	60	48	12	24	12	19	M12x1.25	24	32.0	0.15	P1C-4LRC	P1S-4LRD
50	32	72.0	80	64	16	32	16	25	M16x1.5	32	41.5	0.35	P1C-4MRC	P1S-4MRD
63	32	72.0	80	64	16	32	16	25	M16x1.5	32	41.5	0.35	P1C-4PRC	P1S-4PRD
80	40	90.0	100	80	20	40	20	32	M20x1.5	40	50.0	0.75	P1C-4RRC	P1S-4RRD
100	40	90.0	100	80	20	40	20	32	M20x1.5	40	50.0	0.75	P1C-4RRC	P1S-4RRD
125	56	123.5	137	110	30	55	30	45	M27x2	54	72.0	2.10	P1C-4RRC	P1S-4RRD
160/200	71	C.F.	C.F.	144	35	70	35	57	M36x2	72	95	C.F.	L075490036	Consult factory

C.F. = Consult Factory



For inventory, lead times, and kit lookup, visit www.pdnplu.com

Flexo Coupling

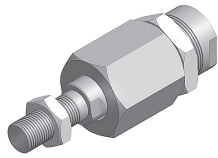

Flexo coupling for articulated mounting of piston rod. Flexo fitting is intended to take up axial angle errors within a range of $\pm 4^\circ$.

Materials:

Flexo coupling, nut: Zinc-plated steel
 Socket: Hardened steel
 Supplied complete with galvanized adjustment nut.

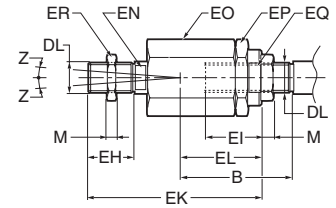

Bore size mm	B min mm	B max mm	DL	EH mm	EI mm	EK mm	EL mm	EN mm	EO mm	EP mm	EQ mm	ER mm	M mm	Z	Weight kg	Part number
32	36.0	43	M10x1.25	20	23	70	31	12	30	30	19	17	5.0	4°	0.21	P1C-4KRF
40	37.0	43	M12x1.25	24	23	77	31	12	30	30	19	19	6.0	4°	0.22	P1C-4LRF
50	53.0	61	M16x1.5	32	32	108	45	19	41	41	30	24	8.0	4°	0.67	P1C-4MRF
63	53.0	61	M16x1.5	32	32	108	45	19	41	41	30	24	8.0	4°	0.67	P1C-4PRF
80	57.0	67	M20x1.5	40	42	122	56	19	41	41	30	30	10.0	4°	0.72	P1C-4PRF
100	57.0	67	M20x1.5	40	42	122	56	19	41	41	30	30	10.0	4°	0.72	P1C-4PRF
125	75.5	89	M27x2	54	48	147	60	24	55	55	32	41	13.5	4°	1.80	P1C-4RRF
160/200	C.F.	C.F.	M36x2	72	50	241	C.F.	36	75	75	50	55	18.0	4°	C.F.	P1C-4SRF

C.F. = Consult Factory

Nuts



Intended for fixed mounting of accessories to the piston rod.

Material: Zinc-plated steel

All P1D cylinders are delivered with a zinc-plated steel piston rod nut.

Stainless Steel Nut

Material: Stainless steel A2

Acid-proof nut

Material: Acid-proof steel A4

Cylinders with acid-proof piston rod are supplied with nut of acid-proof steel.

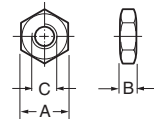

According to DIN 439 B

Bore size mm	A mm	B mm	C	Weight kg	Part numbers		
					Steel	Stainless steel	Acid-proof
32	17	5.0	M10x1.25	0.007	0867340300	9126725404	0261109919
40	19	6.0	M12x1.25	0.010	0867340400	9126725405	0261109920
50	24	8.0	M16x1.5	0.021	0867340600	9126725406	0261109917
63	24	8.0	M16x1.5	0.021			
80	30	10.0	M20x1.5	0.040	0261109911	0261109921	0261109916
100	30	10.0	M20x1.5	0.040			
125	41	13.5	M27x2	0.100	0867340900	0261109922	0261109918
160/200	55	18.0	M36x2	C.F.	L075540036	C.F.	C.F.

C.F. = Consult Factory

B

Tie Rod Pneumatic Cylinders

4MA Series

4MAJ Series

2MNR Series

ACVB Option

LPSO Option

P1D Series



For inventory, lead time, and kit lookup, visit www.pdnplu.com

Accessories

Screw Set for MP2, MP4, MS1 and GA

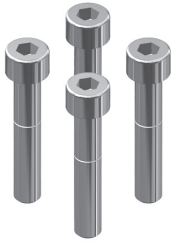

Set of stainless steel screws for fitting clevis brackets MP2, MP4 and GA onto the cylinder. The screws have an internal hexagonal head and are used in special environments, e.g. the food industry, or where there are extra demands for protection against corrosion.

Material:
 According to DIN 912, Stainless steel, A2

4 pcs per pack.

Bore mm	Weight kg	Part number
32	0.02	9301054321
40	0.02	9301054321
50	0.05	9301054322
63	0.05	9301054322
80	0.09	9301054323
100	0.09	9301054323
125	0.15	9301054324

Screw Set for MF1/MF2

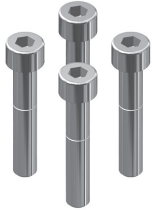

Set of stainless steel screws for fitting flanges MF1/MF2 onto the cylinder. The screws have an internal hexagonal head and are used in special environments, e.g. the food industry, or where there are extra demands for protection against corrosion.

Material:
 According to DIN 6912, Stainless steel, A2

4 pcs per pack

Bore mm	Weight kg	Part number
32	0.02	9301054331
40	0.02	9301054331
50	0.04	9301054332
63	0.04	9301054332
80	0.07	9301054333
100	0.07	9301054333
125	0.12	9301054334

B	Tie Rod Pneumatic Cylinders
	4MA Series
	4MAJ Series
	2MNR Series
	ACVB Option
	LPSO Option
	P1D Series

Service Kits

Grease for P1D Series



Size	Part number
30g (standard)	9127394541

Gland Service Kits: P1D-G and P1D-E Versions

Bore size mm	Rod dia. mm	Rod no.	RG-rod gland cartridge kit Consisting of: rod gland, seals, and wiper	
			Nitrile seals part number	Fluorocarbon seals part number
32	12	1	RG0P1D0121	RG0P1D0125
40	16	1	RG0P1D0161	RG0P1D0165
50 & 63	20	1	RG0P1D0201	RG0P1D0205
80 & 100	25	1	RG0P1D0251	RG0P1D0255
125	32	1	RG0P1D0321	RG0P1D0325
160 & 200	40	1	RG0P1D0401	RG0P1D0405

RK-rod seal kit Consisting of: gland seals, and wiper	
Nitrile seals part number	Fluorocarbon seals Part number
RK0P1D0121	RK0P1D0125
RK0P1D0161	RK0P1D0165
RK0P1D0201	RK0P1D0205
RK0P1D0251	RK0P1D0255
RK0P1D0321	RK0P1D0325
RK0P1D0401	RK0P1D0405

**Piston and End Seal Service Kits:
P1D-G and P1D-E Versions**

Bore size mm	PK – piston seal kit Consisting of: piston seals, wear ring, cylinder body o-rings, and magnetic strip (nitrile only)	
	Nitrile seals part number	Fluorocarbon seals part number
32	PK032P1D01	PK032P1D05
40	PK040P1D01	PK040P1D05
50	PK050P1D01	PK050P1D05
63	PK063P1D01	PK063P1D05
80	PK080P1D01	PK080P1D05
100	PK100P1D01	PK100P1D05
125	PK125P1D01	PK125P1D05
160	PK160MP001	PK160MP005
200	PK200MP001	PK200MP005

B

Tie Rod Pneumatic
Cylinders

4MA
Series

4MAJ
Series

2MNR
Series

ACVB
Option

LPSO
Option

P1D
Series



For inventory, lead time, and kit
lookup, visit www.pdnplu.com

B
Tie Rod Pneumatic Cylinders
4MA Series
4MAJ Series
2MNR Series
ACVB Option
LPS0 Option
P1D Series



For inventory, lead times, and kit lookup, visit www.pdnplu.com